

# Pressure Gauges with Electric Contacts

## MCE10 -MCE18, DS 100

01.M1-M2



They are used to control the electrical operation of compressors, pumps, presses, hydraulic and pneumatics equipment, chemical and petrochemical plant. The contacts open or close the circuit depending on the position of the indicating pointer and they are adjustable over the whole range. For application on severe working conditions, such as rapid and frequent pressure change, vibration and pulsation, they are manufactured with the case liquid filled. The filling drastically reduces the effect of such factors as well as those caused by a corrosive atmosphere, giving longer life and better performances of the pressure gauge and their electric contacts. They are also available with inductive contacts intrinsically safe.

### Functional and constructive characteristics.

#### 01.M1.1 - brass version

**Accuracy:**  $\pm 1,6\%$  as per UNI 8293 - DIN 16085 (1).

**Ambient temperature:** -25...+65 °C.

**Process temperature:** max +65 °C.

**Working pressure:** max 75% of the full scale value.

**Over pressure:** not suitable.

**Protection:** IP 55 as per IEC 529.

**Socket material:** brass OT 58 .

**Elastic element:** phosphor bronze for pressure ranges - 40 bar;  
AISI 316 L st.st. for pressure ranges <sup>3</sup> 60 bar.

**Welding:** tin-copper alloy.

**Case:** AISI 304 st.st.

**Ring:** AISI 304 st.st., bayonet lock.

**Window:** Plexiglas.

**Movement:** stainless steel.

**Dial:** aluminium, white with black markings.

**Pointer:** black anodized aluminium.

**Window gasket:** EPDM.

**Blow out gasket and filling plug:** EPDM.

#### 01.M1.3 - brass version, filled.

**Filling liquids:** silicon dielectric oil.

**Protection:** IP 65 as per IEC 529.

**Blow out gasket and filling plug:** Viton.

**Window gasket:** silicon gum.

#### 01.M2.1 - st.st. version

**Accuracy:**  $\pm 1,0\%$  as per UNI 8293 - DIN 16085 (1).

**Ambient temperature:** -25...+65 °C.

**Process temperature:** max +100 °C.

**Working pressure:** max 75% of the full scale value.

**Over pressure:** not suitable.

**Protection:** IP 55 as per IEC 529.

**Socket material:** AISI 316L st.st.

**Elastic element:** AISI 316L st.st.

**Welding:** AISI 316 T.I.G.

**Case:** AISI 304 st.st.

**Ring:** AISI 304 st.st., bayonet lock.

**Window:** Plexiglas.

**Movement:** stainless steel.

**Dial:** aluminium, white with black markings.

**Pointer:** black anodized aluminium.

**Window gasket:** EPDM.

**Blow out gasket and filling plug:** EPDM.

#### 01.M2.3 - st.st. version, filled.

**Accuracy:**  $\pm 1,6\%$  as per UNI 8293 - DIN 16085 (1).

**Filling liquid:** silicon dielectric oil.

**Protection:** IP 65 as per IEC 529.

**Blow out gasket and filling plug:** Viton.

**Window gasket:** silicon gum.

(1) The addition of mechanical electric contacts affects the accuracy of instruments such that 1% becomes 1,5%, 1,6% becomes 2,4% etc. (add the 50% of accuracy; if the contact is of the magnetically assisted type, this value can't be added within the  $\pm 5\%$  of setting point).

TYPES, DIMENSIONS AND WEIGHTS

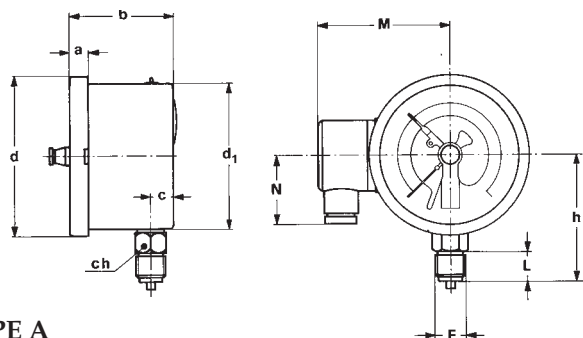

**TYPE A**  
stem mounting;  
lower connection.

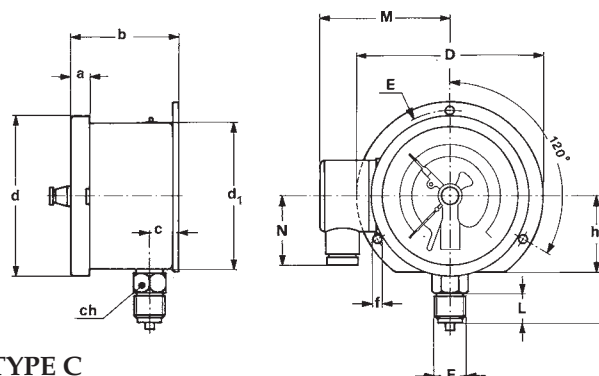

**TYPE C**  
surface mounting, back flange;  
lower connection.

Type	F	a	b (1)	c	d	d <sub>1</sub>	e	f	h	h <sub>1</sub>	p	D	E	M	N	L	ch	Weight 01.M1-M2.1	Weight 01.M1-M2.3
A	1/2" BSP or NPT	13	71,5/82,5	16	110	101	-	-	87	52	-	130	116	90	46	20	22	0,7 Kg.	1,05 Kg.
C	1/2" BSP or NPT	13	75,5/86,5	20	110	101	-	6	87	52	-	130	116	90	46	20	22	0,75 Kg.	1,2 Kg.
D	1/2" BSP or NPT	13	71,5/82,5	-	110	101	31	-	-	-	109	132	118	60	-	20	24	0,7 Kg.	1,05 Kg.
E	1/2" BSP or NPT	13	71,5/82,5	-	110	101	31	6	-	-	109	132	118	60	-	20	24	0,8 Kg.	1,3 Kg.

(1) dimensions for single/double contact

(dimensions : mm.)

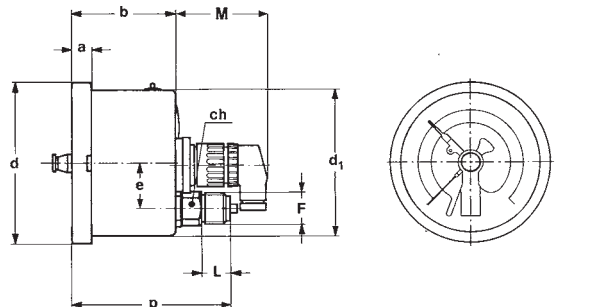

**TYPE D**  
stem mounting;  
back connection.

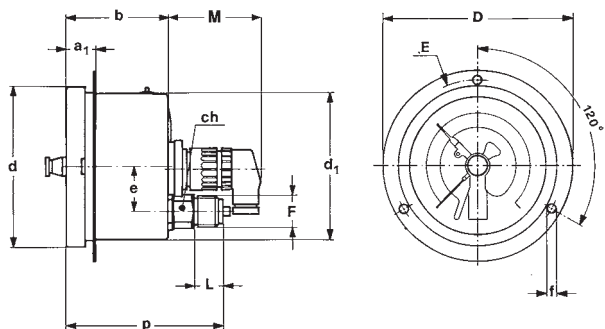

**TYPE E**  
flush mounting, front flange;  
back connection.

RANGES

TAB. 1

Ranges	bar	Kg/cm <sup>2</sup>	kPa	MPa
0...1	◆	◆		◆
0...1,6	◆	◆		◆
0...2,5	◆	◆		◆
0...4	◆	◆		◆
0...6	◆	◆		◆
0...10	◆	◆		◆
0...16	◆	◆		◆
0...25	◆	◆		◆
0...40	◆	◆		◆
0...60	◆	◆		◆
0...100	◆	◆	◆	◆
0...160	◆	◆	◆	◆
0...250	◆	◆	◆	
0...400	◆	◆	◆	
0...600	◆	◆	◆	
0...1000	◆	◆	◆	
0...1600	◆♣	◆♣	◆	

♣ for 01.M2 only

TAB. 2

Ranges	psi
0...15	◆
0...30	◆
0...60	◆
0...100	◆
0...160	◆
0...200	◆
0...300	◆
0...400	◆
0...600	◆
0...1000	◆
0...1500	◆
0...2000	◆
0...3000	◆
0...4000	◆
0...5000	◆
0...6000	◆
0...10000	◆
0...15000	◆
0...20000	◆

### Sliding contacts

The electrical sliding contacts guarantee an accurate operation within a controlled hysteresis. However they are rather sensitive to vibration, moreover, very slow pressure changes may cause an electric arc which can reduce its working life.

### Magnetic Snap-Action Contacts

This type of contact is universally used to guarantee the reliable operation of gauges under severe vibration. The magnetic action is guaranteed by a "click operation", which improves contact capacity, life and is less sensitive to vibration. The required power to overcome the magnetic resistance causes an hysteresis at set-point between 2% to 5% of full scale value.

### Functional and constructive characteristics

**Set-point accuracy:** 150% of instrument accuracy.  
**Set-point hysteresis:** 0,3% of full scale value.  
**Break rating:** 10W/18VA.  
**Maximum rating:** 250Vac/0,7A (ohmic load).  
**Contact material:** Silver-Nickel 80/20%.  
**Contact setting:** over an arc of 270°, by a fixed key fitted to the front lens or by a removable key.  
**Electrical wiring:** junction box as per VDE, see table at page 4.

### Functional and constructive characteristics

**Set-point accuracy:** 150% of instrument accuracy.  
**Set-point hysteresis:** 2...5% of full scale value.  
**Break rating:** 30W/50VA (20W/20VA for filled version).  
**Maximum rating:** 250Vac/1A (ohmic load).  
**Contact material:** Silver-Nickel 80/20%.  
**Contact setting:** over an arc of 270°, by a fixed key fitted to the front lens or by a removable key.  
**Electrical wiring:** junction box as per VDE, see table at page 4.

#### LOAD RATINGS (1)

Volt	DC	AC	Inductive load
220	40 mA	45 mA	25 mA
110	80 mA	90 mA	45 mA
48	120 mA	170 mA	70 mA
24	200 mA	350 mA	100 mA

Vdc Minimum values : 24Vdc/20mA.

#### LOAD RATINGS (1)

Volt	DC	AC	Inductive load
220	100 mA	120 mA	65 mA
110	200 mA	240 mA	130 mA
48	300 mA	450 mA	200 mA
24	400 mA	600 mA	250 mA

Vdc Minimum values : 24Vdc/20mA.

#### liquid filled pressure gauges







Volt	CC	CA	Carico induttivo
220	65 mA	90 mA	40 mA
110	130 mA	180 mA	85 mA
48	190 mA	330 mA	130 mA
24	250 mA	450 mA	150 mA

Vdc Minimum values : 24Vdc/20mA.

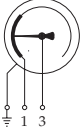
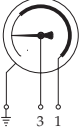
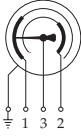
(1) as per DIN 16085.

### CONTROL RELAYS

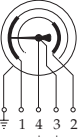
We recommend the use of control relays as they increase the working life of all types of contacts. For intrinsically safe applications an appropriate barrier must be used.

WIRING SCHEME (1)	ELECTRIC SCHEME (before set)	CLOCKWISE MOVEMENT OF THE POINTER CAUSES:	JUNCTION BOX		CONTACT CODE	
			01.M1-M2.1	01.M1-M2.3	sliding	magnetic snap-action
<b>SINGLE CONTACT</b>						
MINI 	3 — o — o — 1	<u>Opening</u>	3 poles Pg. 9	Types A,C: 6 poles - Pg. 13,5 Types D,E: 3 poles - Pg. 9	01S	01S.BM1
MAXI 	3 — o — o — 2	<u>Closing</u>	3 poles Pg. 9	Types A,C: 6 poles - Pg. 13,5 Types D,E: 3 poles - Pg. 9	02S	02S.BM1
<b>DOUBLE CONTACT (2)</b>						
1° MINI 2° MAXI 	3 — o — o — 1 3 — o — o — 2	<u>Opening 1</u> <u>Closing 2</u>	3 poles Pg. 9	Types A,C: 6 poles - Pg. 13,5 Types D,E: 3 poles - Pg. 9	01D	01D.BM2
1° MAXI 2° MAXI 	3 — o — o — 1 3 — o — o — 2	<u>Closing 1</u> <u>Closing 2</u>	3 poles Pg. 9	Types A,C: 6 poles - Pg. 13,5 Types D,E: 3 poles - Pg. 9	02D	02D.BM2
1° MAXI 2° MINI 	3 — o — o — 2 3 — o — o — 1	<u>Closing 2</u> <u>Opening 1</u>	3 poles Pg. 9	Types A,C: 6 poles - Pg. 13,5 Types D,E: 3 poles - Pg. 9	03D	03D.BM2
1° MINI 2° MINI 	3 — o — o — 1 3 — o — o — 2	<u>Opening 1</u> <u>Opening 2</u>	3 poles Pg. 9	Types A,C: 6 poles - Pg. 13,5 Types D,E: 3 poles - Pg. 9	04D	04D.BM2
<b>INDEPENDENT DOUBLE CONTACT (2)</b>						
1° MINI 2° MAXI 	3 — o — o — 2 4 — o — o — 1	<u>Opening 1</u> <u>Closing 2</u>	Types A,C: 6 poles - Pg. 13,5 Types D,E: 6 poles - Pg. 9	Types A,C: 6 poles - Pg. 13,5 Types D,E: 6 poles - Pg. 9	08D	08D.BM2
1° MAXI 2° MAXI 	3 — o — o — 2 4 — o — o — 1	<u>Closing 1</u> <u>Closing 2</u>	Types A,C: 6 poles - Pg. 13,5 Types D,E: 6 poles - Pg. 9	Types A,C: 6 poles - Pg. 13,5 Types D,E: 6 poles - Pg. 9	09D	09D.BM2

(1) The above numbers are the same of those stamped on the junction box.

(2) Each contact must not exceed the next one.

# pressure gauges with electric contacts

## INDUCTIVE SYSTEM - MCE10-18 DS 100

# 01.M1-M2

Inductive contacts are intrinsically safe and certified to EN 50014/50020 norm with protection degree EEX ia IIC T6. To guarantee such protection degree the contacts must be supplied via a control relay which has the same type of certificate (see our catalogue sheet 08.W01-W02). When mounted on instruments with liquid filled case (models 01.M1.3, 01.M2.3) they are particularly suitable for application on chemical and petrochemical plants with vibrations and frequent operation.

The inductive system consists of an inductive sensor that operates without mechanical contact and an external control unit.

The control head of inductive sensor contains a transistorized oscillator and two axial coils. The magnetic coupling between the two axial coils is changed by a control flag which is moved by the pointer. This action changes the internal control unit current which is used actual to trigger a switch amplifier which makes the real switching. For further information see our data-sheet 08.W01-W02.

### Functional and constructive characteristics

**Set-point accuracy:** 150% of instrument accuracy.

**Set-point hysteresis:** 0,3...1% of full scale value.

**Contact setting:** over an arc of 270°, through the knob placed on front lens or through removable key.

**Electric wiring:** junction box as per VDE, see underdraw table.

#### LOAD RATINGS (of the control unit output relay)

Volt	DC	AC
220	0,1 A	4 A
110	0,2 A	4 A
48	0,6 A	4 A
24	4 A	4 A

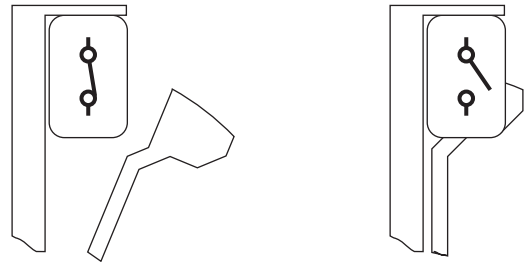

WIRING SCHEME (1)	ELECTRIC SCHEME (before set)	CLOCKWISE MOVEMENT OF THE POINTER CAUSES:	JUNCTION BOX		CONTACT CODE
			01.M1-M2.1	01.M1-M2.3	
<b>SINGLE CONTACT</b>					
<b>MINI</b> 		Insertion of control flag into control head and <b>Opening</b>	<b>3 poles</b> Pg. 9	Types A,C: <b>6 poles - Pg. 13,5</b> Types D,E: <b>3 poles - Pg. 9</b>	<b>B1</b>
<b>MAXI</b> 		Release of control flag from control head and <b>Closing</b>	<b>3 poles</b> Pg. 9	Types A,C: <b>6 poles - Pg. 13,5</b> Types D,E: <b>3 poles - Pg. 9</b>	<b>B2</b>
<b>DOUBLE CONTACT (2) (3)</b>					
<b>1° MINI</b> <b>2° MAXI</b> 		Insertion of control flag into control head n. 1, release of control flag from control head n. 2 and <b>Opening 1</b> <b>Closing 2</b>	Types A,C: <b>6 poles - Pg. 13,5</b> Types D,E: <b>6 poles - Pg. 9</b>	Types A,C: <b>6 poles - Pg. 13,5</b> Types D,E: <b>6 poles - Pg. 9</b>	<b>B12</b>
<b>1° MAXI</b> <b>2° MAXI</b> 		Insertion of control flags into control heads <b>Closing 1-2</b>	Types A,C: <b>6 poles - Pg. 13,5</b> Types D,E: <b>6 poles - Pg. 9</b>	Types A,C: <b>6 poles - Pg. 13,5</b> Types D,E: <b>6 poles - Pg. 9</b>	<b>B22</b>

(1) The above numbers are the same of those stamped on the junction box.

(2) Each contact must not exceed the next one.

(3) Other electric contacts are available upon request.

## MINIMUM RANGES FOR CONTACT TYPES

Contact type		Sliding contact		Magnetic snap-action contact		Inductive sensor	
Contact number		1	2	1	2	1	2
MODEL	DS	Minimum range		Minimum range		Minimum range	
01.M1.1-01.M2.1	100	1 bar	1,6 bar	1 bar	1,6 bar	1 bar	1,6 bar
01.M1.3-01.M2.3	100	-	-	1,6 bar	2,5 bar	1,6 bar	2,5 bar

## OPTIONS

Description	CODE	01.M1.1-01.M2.1	01.M1.3-01.M2.3
Single magnetic snap-action (1)	BM1	◆	STD
Double magnetic snap-action (1)	BM2	◆	STD
Oxygen service M049	P02	◆	
Stainless steel label (2)	T25	◆	◆

(1) To be added to the code of standard air contact to change it into magnetic type contact: choose BM1 or BM2 depending if contact is single or double.

(2) Not available tag on dial.

## HOW TO ORDER

	CODE & DESCRIPTION
<b>01</b>	01- bourdon tube pressure gauges
<b>M2</b>	M1 - brass wetted parts MCE10 M2 - AISI 316L st.st. wetted MCE18
<b>3</b>	1 - dry version 3 - filled version
<b>C</b>	A - lower connection - stem mounting C - lower connection - surface mounting, back flange D - back connection - stem mounting E - back connection - flush mounting, front flange
<b>E</b>	E - DS100
<b>2</b>	1 - up to 2,5 bar 2 - from 4 to 40 bar 3 - over 40 bar
<b>0/10 bar</b>	see ranges table
<b>41M</b>	21M - 1/4" BSP (1) 23M - 1/4" NPT (1) 31M - 3/8" BSP (1) 33M - 3/8" NPT (1) 41M - 1/2" BSP 43M - 1/2" NPT
<b>01D</b>	see description at pag. 4 and 5
<b>BM1</b>	see OPTIONS table

(1) for 01.M1.1-01.M1.3 only.



**DRUCK & TEMPERATUR Leitenberger GmbH**  
Postfach 64 • D-72136 Kirchentellinsfurt • Germany  
Tel.: 0 71 21 - 9 09 20 - 0 • Fax: 0 71 21 - 9 09 20 - 99  
E-Mail: dt-info@leitenberger.de  
INTERNET-Site: <http://www.leitenberger.de>