

User Manual of Sandwich Ultrasonic Water meter



Contents

1. Introduction	- 4 -
1.1 Preface	- 4 -
1.2 Features	- 4 -
2. Product Introduction	- 5 -
2.1 Data Sheet	- 5 -
2.2 Dimension&Weight	- 6 -
2.3 Performance Error Curve	- 6 -
2.4 Flow Range	- 7 -
3. Installation Instruction	- 8 -
3.1 Choose the installation point	- 8 -
3.2 Installation Method	- 8 -
3.3 Communication and Signal Output	- 9 -
4. Menu Windows	- 10 -
4.1 Display and Operation	- 10 -
4.2 Operation Method	- 11 -
4.3 Digital Display Table	- 12 -
4.4 Main Menu	- 14 -
4.5 Secondary Menu 1	- 17 -
4.6 Secondary Menu 2	- 19 -
4.7 Month Cumulative Data Menu	- 21 -
4.8 Date Cumulative Data Menu	- 21 -
4.9 Batch Controller and Time-accumulated Menu	- 22 -
5. How To	- 26 -
5.1 How to modify the unit	- 26 -
5.2 How to modify the cumulative flow of the decimal point position	- 26 -

5.3 How to reset the time.....	- 26 -
5.4 How to judge the water meter works properly.....	- 26 -
5.5 How to operate the calibration windows.....	- 27 -
5.6 How to operate the built-in batch controller.....	- 28 -
5.7 How to modify time point of the time-accumulator.....	- 28 -
5.8 How to modify the communication address.....	- 29 -
5.9 How to reset the secondary address of M-BUS.....	- 29 -
5.10 How to modify the infrared communication rate.....	- 30 -
5.11 How to modify communication rate of RS485/M-bus.....	- 30 -
6. Communication.....	- 31 -
6.1 Communication and Networking.....	- 31 -
7. Fault Handling.....	- 32 -
7.1 Fault Handling.....	- 32 -

1. Introduction

1.1 Preface

The TFMW-1 series is specially designed for urban water supply and building-use according to the GBT 778.1-2007、ISO-4064、JJG162-2009 standard.

The conventional water meters suffer from the drawbacks that they are only operable at a higher flow rate and are insensitive to a small flow rate. However, the water meter can help tackle the bottleneck. And the meter is highly adaptable to diversified industrial conditions.

The water meter be adapted by the company's newly-developed unique advanced transit-time measurement technology , with the remarkable features of low power consumption, wide measuring range ratio, stable and reliable measurement.

In the structure, the components take the IP68 program, that is, each component is of an IP68 protection level, to ensure long time operation though water in the inside meter. The wireless power and various communication interface can be matched to the meter to achieve remote meter reading.

This series of water meter's production process is automatic or semi-automatic, including automatic detection of circuit boards, the automation of the circuit board's high-low temperature test machine, the automation of potting and calibration process, ensuring that every machines out of the factory are qualified.

1.2 Features

- High accuracy and reliable operation
- Less than 0.01 m/s starting velocity
- Multi line 9 digital LCD accumulative flow and 4 digital for instantaneous flow
- Automatic power saving function under the empty pipe or long-term fluid stationary state
- IP68 protection, ensure long-term operation though water in the inside meter
- Date cumulative record and data acquisition function
- Various kinds of communication interface: TTL levels pulse output and USART interface, convenient to connect the low power consumption equipment; RS485; Infrared communication interface; support CJ-188 communication
- Support MODBUS, M-BUS ,HART communication protocol
- Output: Two way isolated pulse output(pulse equivalent and output pulse can be arbitrary programmed); two-wired system 4-20mA output
- Software online upgrade function
- With the two way PT1000 temperature transducer, which can realize the heat measurement
- Built-in batch controller and time accumulator
- Various of Units selected, including Cubic meter, USA gallon, Cubic feet and Liter
- Built-in Lithium battery for 6 years life expectancy

2. Product Introduction

2.1 Data Sheet

Item	Specification
Measurement Range	Water, Sewage, Seawater(Other liquid need to customized), liquid should be full of the pipeline
Medium Temperature	0.1-30℃
Working Environment	Temperature : -10~45℃ ; Humidity≤100% (RH)
Working Pressure	1.6MPa/2.5Mpa optional
The sensitivity of upstream flow field	U5
The sensitivity of downstream flow field	D3
Climatic and mechanical environment class	C class
Electromagnetic compatibility class	E2 class
Communication Interface	RS485/USART/Infrared
Output Signal	Two way OCT output/TTL pulse output/4-20mA output
Power supply	Built-in Lithium battery(3.6V)/ External DC 8~36V
Protection Class	IP68
Digital Display	Multi line 9 digital LCD display accumulative flow, 4 digital display for instantaneous flow, state prompt and units
Data Storage	EEPROM/FLASH
Measurement Cycle	Measuring : 1 times/second (2~4 times/second optional) ; Verification : 4 times/second
Power Consumption	< 2.7AH/Year, 6 years life expectancy

2.2 Dimension&Weight

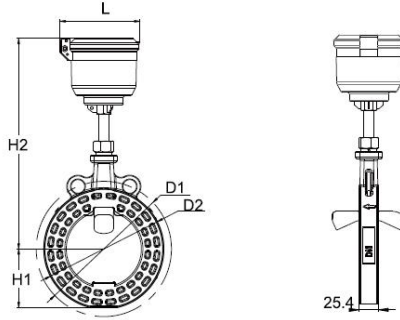

Unit : mm

Nominal Size DN(mm)	Dimension			Flange Size				Weight kg	Pressure MPa
	L	H1	H2	Outer Diameter D1	Central circle diameter of bolt holes D	Bolt Hole			
						Bore diameter × Quantity $\Phi \times n$	Quantity		
DN80	147	68	280	140	160	18×8	2	2.2	1.6
DN100	147	78	270	160	180	18×8	2	2.3	1.6

2.3 Performance Error Curve

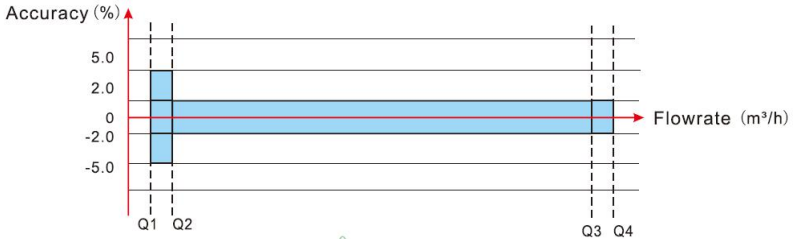

2.4 Flow Range

Nominal Diameter (mm)	R	Flow (m ³ /h)				
		Starting Flowrate	Minimum Flowrate Q1	Transitional Flowrate Q2	Permanent Flowrate Q3	Overload Flowrate Q4
DN80	40	0.625	2.500	4.000	100.000	125.000
DN100	40	1.000	4.000	6.400	160.000	200.000

3. Installation Instruction

3.1 Choose the installation point

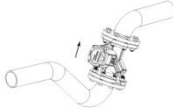
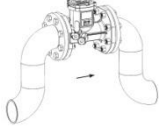
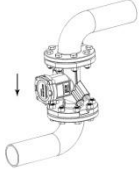
Correct installation point		Wrong installation point	
			

ps: Arrow direction is fluid flow direction.

3.2 Installation Method

(1) Cut the pipeline on the installation point, the cutting length according to the water meter dimension (Water meter length L+sealing gasket thickness+10mm)



(2) Pls choose 3 point on the flange to be spot-welded, then take off the water meter, finish full welding the flange



(3) After the welding flange cooling, pls install the water meter between the flange with sealing washer and fasten the screw

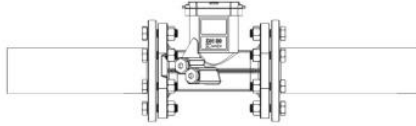

ps : Arrow direction is fluid flow direction.

3.3 Communication and Signal Output

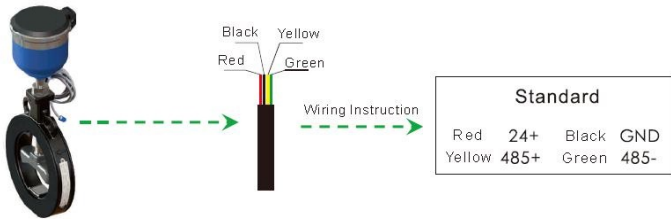

Can complete the wiring junction without opening the water meter cover

Provide below communication interface and output

1. RS485
2. M-BUS
3. DC8-36V
4. Two-wired system 4-20mA output
5. OCT1(open collector output 1)
6. OCT2 (open collector output2)
7. C1(TTL level pulse output 1)
8. C2(TTL level pulse output 2)



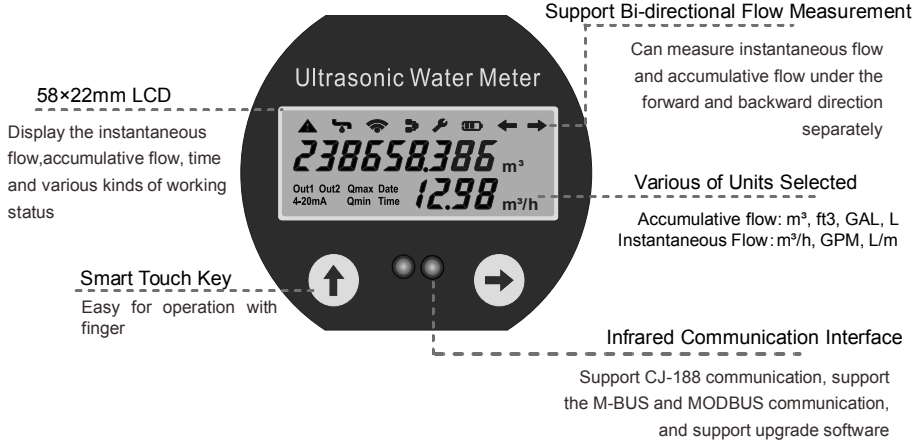

PS: when ordering, you can choose any two of the above communication interface or output, lead to the external junction box

4. Menu Windows

4.1 Display and Operation







Display Description



- | | | | |
|--|-----------------------|---|--------------------------------|
|  | Alarm/Error |  | Leak Detector |
|  | Wireless Power Supply |  | Communication |
|  | Permanent Fault |  | Battery Low Warning |
|  | Liquid Direction |  | 4-20mA Current Loop Connection |
| Out1 Out2 | Pulse Output | | |



4.2 Operation Method





V51 ultrasonic water meter is equipped with two capacitive touch keys, easy for operation. Due to operation through the thick glass, press the keys hard with your fingers and contact wide surface of the glass ensure capacitive keys responsive





Two capacitive keys, include “” and “”.

Key “” and “” is up and down when under the modification states;

Key“” makes the Menu number increased, when enter Key “”, Menu number move in sequential, display recycled on this level Menu windows





Key “” makes the cursor move to next character position, when enter Key “”, Menu number move in sequential, display recycled on this level Menu windows

Press and hold the key “”, do not release the key“”, then press key “”, that is the key “”, called modification key. Key“” means enter into the next level menu windows, or means enter into modification states

Press and hold the key “”, do not release the key “”, then press key “”, that is the key“”, called exit key. Press key “” will back to M00, or exit from the modification states.

If there is no typing a key in 2 hours, the display will be back to M00 automatically

In order to the power saving, when there is no typing a key for more than 10 minutes, quick key scan will be changed into slow key scan (1 seconds per times), which the key may appear unresponsive, under this situation, press long key(press any keys for more than 3 seconds and loosen called Long key) to activate the quick key scan, then is the normal operation

Keyboard mnemonic: left click“” is up; right click“” is down; left-right click“” is modification ; right-left click“” is exiting

4.3 Digital Display Table

Windows	NO.	Windows Functions	Description
Main Menu	M00	Water meter: Display positive cumulative flows and instantaneous flows Heat meter: Display POS (positive) cumulative heats and instantaneous heats	Key ↕ , enter into Month cumulative
	M01	Display POS cumulative flows and instantaneous flows (water meter without this Menu)	
	M02	Display the supply and return water temperature and temperature difference (water meter without this Menu, unit is only °C)	
	M03	Calendar, first line display date and week; Second line display the hour and minute	Key ↕ , enter into M10
	M04	First line display two way signal strength, failure error code; Second line display two way signal quality	Key ↕ , enter into data cumulative
	M05	Calibration menu	Key ↕ , enter into constant-current calibration
	M06	Batch controller (irrigation controller)	Key ↕ , enter into controller setting
Secondary Menu 1	M10	Display the ESN (Electronic Serial numbers) and the software version number	
	M11	Display the calendar, date and time	Key ↕ , can be modified
	M12	Display the date of setting up parameters and battery voltage (in volts)	
	M13	Display the M-BUS second address and main address	Key ↕ , main address can be modified
	M14	Display the bound rate of RS485 and infrared interface	
	M15	Display the total work time (in hours) and fluid velocity	
	M16	Display the failure time (in hours) and CPU temperature	
	M17	Display the time of negative flow and Coefficient of the module	
	M18	Display temperature transducer equivalent resistance value and frequency coefficient	
	M19	Display the LCD segment code, is used to check defective display	Key ↕ , enter into M20
	M20	Display the negative cumulative flow and the pipe diameter	

Secondary Menu 2	M21	Display the negative cumulative heats and instrument factor	
	M22	Display Today's POS (positive)cumulative flows and the number of transducer channel	
	M23	Display current Month's POS (positive)cumulative flows and number of measurement per second	
	M24	Display Year's POS (positive)cumulative flows and low cut off flow value	
	M25	Display the data record dates and hardware delay time	
	M26	Display Today's POS (positive)cumulative heats and the power on times	
	M27	Display Month's POS (positive)cumulative heats and the current valve from the current loop	
	M28	Display the first failure time	Press key $\uparrow \rightarrow$ to clear
	M29	Display current Reynolds number and Renault correction factor	
	M2A	Display the total transmission time (us) and time difference (nS)	Press password"1111" to modify
Batch Control Menu	M30	Batch controller switch control	Key $\uparrow \rightarrow$, can be modified
	M31	Batch controller enable-control (under the enable-control state, it will take OCT 2 as signal output)	Key $\uparrow \rightarrow$, can be modified
	M32	Set the controller point value, such as 2.00 m ³ , can be set by keypad	Key $\uparrow \rightarrow$, can be modified
	M33	Set up #T1 batch controller start time	Key $\uparrow \rightarrow$, can be modified
	M34	Set up #T2 batch controller start time	Key $\uparrow \rightarrow$, can be modified
	M35	Set up #T3 batch controller start time	Key $\uparrow \rightarrow$, can be modified
	M36	Set up #T4 batch controller start time	Key $\uparrow \rightarrow$, can be modified
	M37	Set up #T5 batch controller start time	Key $\uparrow \rightarrow$, can be modified
Time-accumulated Menu	M38	Display #2 time-accumulator and instantaneous flow or instantaneous heat	
	M39	Display #3 time-accumulator and instantaneous flow or instantaneous heat	

M3A	Set up #2 and #3 time-accumulator stop time	Key ↕ , can be modified
M3B	Set up #2 time-accumulator start time(#3 time-accumulator stop)	Key ↕ , can be modified
M3C	Set up #3 time-accumulator start time(#2 time-accumulator stop)	Key ↕ , can be modified
M4X	Display month cumulative flow	
M5X	Display day cumulative flow	

Menu introduction:

TFMW-1series ultrasonic water meter include 5 kinds of menus: main menu, secondary menu1, secondary menu2, batch control menu and time-accumulated menu. Under the main menu, you can enter into any menu by the modification key "**↕**".

Example:

M00, press "**↕**" enter into the month cumulative flow;

M03, press "**↕**" enter into secondary menu1 (M10~M19);

Under the M19 of the secondary men1, press "**↕**" enter into secondary menu2 (M20~M2A);

M04, press "**↕**" enter into date cumulative flow;

M05, start-stop method calibration state; press "**↕**" enter into constant-current method calibration state;

M06, press "**↕**" enter into batch control and time-accumulated menu(M30~M3C);

4.4 Main Menu

V51 water meter is consist of 7 main menu windows(as a water meter, only display 5 main menu windows. The 7 main menu windows is M00, M01, M02, M03, M04, M05, M06 respectively.

Key "**↕**" or "**↕**", display the 7 menu windows cyclical. Example: in the M00, if press key "**↕**", will enter into M06, in the M06, if press key "**↕**", will back to M00.

Please note that the 7 menu windows are with the special differences, example:

M00, there is the cumulative flow and instantaneous flow or heats unit
on the right display

M02, there is the temperature unit °C

M03, there is the symbol "-" between date, time, year and month

M04, there is no any unit symbol, when in normal operation,
the first line 8 character is 00000000

M05, there is the character “1” or “P”, “C” displayed on the left

M06, there is the character of “bC” displayed on the left

Below the windows function:

Windows	No.	Windows Function
Main Menu	M00	Water meter: Display Positive cumulative flows and instantaneous flows Heat meter: Display POS (positive) cumulative heats and instantaneous heats
	M01	Display POS cumulative flows and instantaneous flows (water meter without this Menu)
	M02	Display the supply and return water temperature and temperature difference (water meter without this Menu, unit is only °C)
	M03	Calendar, first line display date and week; Second line display the hour and minute
	M04	First line display two way signal strength, failure error code; Second line display two way signal quality
	M05	Calibration menu
	M06	Batch controller (irrigation controller)

Below detailed description of the main menu:

M00 Water meter: Net cumulative flows/instantaneous flows

Heat meter: Positive cumulative heats/instantaneous heats

If is set to water meter, display Net cumulative flows and instantaneous flows; If is set to heat meter, display POS (positive) cumulative heats and instantaneous heats. Units and cumulative flow of decimal point position can be modified only by the special parameter software, pls refer to §8.1 and §8.2. If the second line display “U”, means the instantaneous heats is less than the cut off value.



**M01 POS cumulative flows and instantaneous flows
(water meter without this Menu)**

Display POS cumulative flows and instantaneous flows.

Units and cumulative flow of decimal point position can be modified only by the special parameter software, pls refer to §5.1 and §5.2. If the second line display “U”, means the instantaneous heats is less than the cut off value.

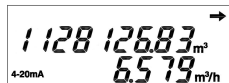

**M02 Supply and return water temperature and
temperature difference(water meter without this Menu,
unit is only °C)**

(Display the supply and return water temperature and temperature difference

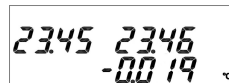

M03 Calender, Date,Week/ Hour and Minute

Display the Date, time, week, the behind of the Date is week, example, 3 is Wednesday.



M04 Two way signal strength,failure error code/

Two way signal quality

The first number of the first line(example:6) display two way signal strength alternately, the max value of the signal strength is 9; the last 8 digits of the first line is error code, it displays “00000000” under the normal working status. The second line display two way signal quality, the max value is 99, the larger of the value, the better of the signal quality.



M05 Calibration Menu

Calibration menu, pls refer to § 5.5



M06 Batch controller Menu(irrigation controller)

Batch controller (irrigation controller),pls refer to § 5.6



4.5 Secondary Menu 1

Under the Calender windows, M03, press and hold the key “▲”, do not release the key“▲”, then press key “▶”, that is the key “▲▶”, called modification key, will display the below :



PASSCode:
0000

Press key“▲” to increase the number of the flashing point until the numbers you required, press key“▶”, the flashing will move to next number, and press“▲” again, operation repeatedly until you finished what you want exactly.

If you want to quit, press “▶▲”, the display will back to M00.

The password is “1111” if you want to enter into the secondary menu.

There are 10 sub menu under the secondary menu 1.

Press key“▲” or key “▶”, will display the 10 sub menu in cycle.

If the menu can be modified, press and hold the key “▲”, do not release the key“▲”, then press key “▶”, will enter into the modification states. If the menu cannot be modified, will enter into the next sub menu.

Windows	NO.	Windows Function	
Secondary Menu 1	M10	Display the ESN(Electronic Serial numbers) and the software version number	
	M11	Display the calendar, date and time	Can be modified
	M12	Display the date of setting up parameters and battery voltage(in volts)	
	M13	Display the M-BUS second address and main address	Main address can be modified
	M14	Display the bound rate of RS485 and infrared interface	
	M15	Display the total work time(in hours) and fluid velocity	
	M16	Display the failure time(in hours) and CPU temperature	
	M17	Display the working time of negative cumulative flow and Coefficient of the capacitor module	
	M18	Display temperature transducer equivalent resistance value and frequency coefficient	
	M19	Display the LCD segment code , is used to check defective display	

Below detailed description of the secondary menu 1:

M10 ESN(Electronic Serial numbers) and the software version number

The first line display the ESN; The second line display the software version number, 51 means the version 51 circuit board



M11 Calender, Date, Time and Week

Calender, press key "↑→", means press and hold key "↑", don't release key "↑", then press key "→", which can modify the Date and Time



M12 The date of setting up parameters and battery voltage(in volts)

Display the date of setting up parameters and battery voltage(in volts)



M13 M-BUS second address and main address

Display M-BUS second address and main address(press "↑→" can be modified)



M14 Bound rate of RS485 and infrared interface

The first line is RS485 bound rate, the "n" is None Parity, the second line is infrared interface bound rate, the last "n" of the first line is infrared interface None Parity.



M15 Total work time(in hours) and fluid velocity

Display the total work time(in hours) and fluid velocity, unit is m/s.



M16 Failure time(in hours) and CPU temperature

Display failure time(in hours), the second line display CPU temperature(°C)



M17 Working time of negative cumulative flow and Coefficient of the capacitor module

The first line display negative cumulative working time, the second line display the capacitor module coefficient.

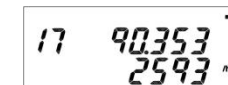

M18 Temperature transducer equivalent resistance value and frequency coefficient

The first line display the equivalent temperature resistance value(the actual value should be add 600);



Second line is frequency coefficient , this value should be < 2.0

M19 LCD segment code , is used to check defective display

Display LCD segment code, used for checking. This windows is also the entrance of M2X.



4.6 Secondary Menu 2

Under the M19, press and hold the key “↑”, do not release the key“↑”, then press key “→”, that is the key “↑→”, called modification key, then will enter into secondary menu 2. There are 11 sub menu totally under the secondary menu 2:

Windows	No.	Windows Function	
Secondary Menu 2	M20	Display negative cumulative flow and the pipe diameter	
	M21	Display the negative cumulative heats and instrument factor	
	M22	Display Today's POS (positive)cumulative flows and the number of transducer channel	
	M23	Display current Month's POS (positive)cumulative flows and number of sampling per second	
	M24	Display Year's POS (positive)cumulative flows and low cut off flow value	
	M25	Display the data record dates and hardware delay time	
	M26	Display Today's POS (positive)cumulative heats and the power on times	
	M27	Display Month's POS (positive)cumulative heats and the current valve from the current loop	
	M28	Display the first failure time	Press key ↑→ to clear
	M29	Display current Reynolds number and Renault correction factor	
	M2A	Display the total transmission time (us) and time difference (nS)	Press password“1111” to modify

Below detailed description of the secondary menu 2:

M20 Display negative cumulative flow and the pipe diameter

The first line display negative cumulative flow

The second line display pipe diameter



M21 Negative cumulative heats and instrument factor



Display the negative cumulative heats and instrument factor

M22 Today's POS (positive)cumulative flows and the number of transducer channel

Display Today's POS (positive)cumulative flows and the number of transducer channel



M23 Month's POS (positive)cumulative flows and number of sampling per second

Display Month's POS (positive)cumulative flows and number of sampling per second



M24 Year's POS (positive)cumulative flows and low cut off flow value

Display Year's POS (positive)cumulative flows and low cut off flow value(starting flow)



M25 Data record dates and hardware delay time

Display the data record dates and hardware delay time(nS)



M26 Today's POS (positive)cumulative heats and the power on times

Display Today's POS (positive)cumulative heats and the power on times.



M27 Month's POS (positive)cumulative heats and the current valve from the current loop

Display Month's POS (positive)cumulative heats and the current valve from the current loop (mA) .



M28 First failure time

Display the first failure time



M29 Reynolds number and Renault correction factor

Display current Reynolds number and Renault correction factor



M2A Display the total transmission time (us) and time difference (nS)

Display the total transmission time (us) and time difference (nS) .



Press key "▲◆", then pres password "1112", can be operated to Zero

4.7 Month Cumulative Data Menu

In M00, press key “**↕↔**”, will enter into the Month cumulative data display menu.

Press key “**↔**”, display the last month cumulative value; press key “**↕**”, display the next month cumulative value .

V51can record the cumulative data up to 128 months, each month data with 32 bytes, the data structures pls refer to the communication protocol part.

Key operation, it only display 3 items in cycle: 1.Year and Month; 2. Month positive cumulative flows; 3. Month positive cumulative heats, display as below:

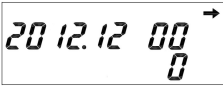

2012.12 00
0

2012.12 means the data in October., 2012

00 means the normal working status.

The second line “0” means the ordinal number. It can up to 256 numbers of data from ordinal number “0-255”



280.985 m³
0

First line display month positive cumulative flow

Second line display data ordinal number. Press “**↔**”, display last month data, the ordinal number will be 1



90.353 kWh
0

First line display month positive cumulative heats

Second line display data ordinal number. Press “**↔**”, display last month data, the ordinal number will be 1

Due to too many months, if want back to ordinal number 0, press the key “**↔↕**” ; if want to exit the cycle display, press “**↔↕**”, back to M00.

4.8 Date Cumulative Data Menu

In M04, press key“**↕↔**”, will enter into the Date cumulative menu.

Press key “**↔**”, display the last day cumulative value; press key “**↕**”, display the next day cumulative value .

V51can record the cumulative data up to 512 working days, each day data with 32 bytes, the data structures pls refer to the communication protocol part.

Key operation, it only display 3 items in cycle: 1.Year and Month and Date; 2. Date positive cumulative flows; 3. Date positive cumulative heats, display as below:



2013.09.21 means the data in 21th, September.2013.

The second line "0" means the ordinal number. It can up to 512 numbers of data from ordinal number "0-511".



First line display Today positive cumulative flow

Second line display data ordinal number. Press"➡", display last day data, the ordinal number will be 1



The first line display Today positive cumulative heat

Second line display data ordinal number. Press"➡", display last day data, the ordinal number will be 1

Due to too many months, if want back to ordinal number 0, press the key "➡⬆";

if want to exit the cycle display, press "➡⬆", back to M00.

if want to exit the cycle display, press "➡⬆", back to M00

4.9 Batch Controller and Time-accumulated Menu

In M06, press key "⬆➡", then enter into batch controller menu .

(If there is the a password required, enter 1111)

There are 10 sub menu under the Batch controller, from M30 to M3C.

If the batch controller work automatically, it is necessary to set up 3 parameter control:

Batch control enable-control, batch control value, batch controller starting time.

OCT2 will be connected to a solenoid valve driver, which will be used to control the valve switch according to the batch controller

When the batch accumulator less than the set value, batch controller is in running states and OCT2 is in high level, therefore, OCT2 is in closed states, the solenoid valve also in closed states, valve is opened.

When the batch accumulator larger than the set value, batch controller is in stopping states and OCT2 is in low level, therefore, OCT2 is in opened states, the solenoid valve also in opened states, valve is closed.

There are 5 internal timer under the batch controller, including #T1,#T2,#T3,#T4,#T5.

User can set up the time controller at any time

Batch controller operation method, pls refer to §5.6

In V51, there are 2 time-accumulators, TARI2 and TARI3, can finish the automatic cumulative within a period of time, the start-stop time also can be set in this menu.

Time-accumulator operation method, pls refer to: §5.7

Windows	NO.	Windows Function	
Secondary Menu 2	M30	Batch controller switch control	can be modified
	M31	Batch controller enable-control (under the enable-control state, it will take OCT 2 as signal output)	can be modified
	M32	Set the controller point value, such as 2.00 m ³ , can be set by keypad	can be modified
	M33	Set up #T1 batch controller start time	can be modified
	M34	Set up #T2 batch controller start time	can be modified
	M35	Set up #T3 batch controller start time	can be modified
	M36	Set up #T4 batch controller start time	can be modified
	M37	Set up #T5 batch controller start time	can be modified
	M38	Display #2 time-accumulator and instantaneous flow or instantaneous heat	
	M39	Display #3 time-accumulator and instantaneous flow or instantaneous heat	
	M3A	Set up #2 and #3 time-accumulator stop time	can be modified
	M3B	Set up #2 time-accumulator start time(#3 time-accumulator stop)	can be modified
	M3C	Set up #3 time-accumulator start time(#2 time-accumulator stop)	can be modified

M30 Batch controller switch control

If the batch controller is "on", press "↕" can turn on or turn off the batch controller, When the batch controller start, the OUT2 will light up.

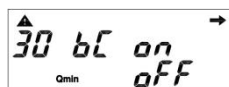

M31 Batch controller enable-control (under the enable-control state, it will take OCT 2 as signal output)

Batch controller switch control, press “**↕**” switch between “En” and “no”. When under the enable-control state, OCT2 only as the batch control signal output

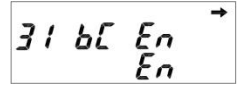

M32 Set the controller point value

Set up the batch controller point value, when enter into a decimal point, pls be patient with the right decimal point number appeared



M33 Set up #T1 batch controller start time

The first line after equal sign “=” , number “0010001” means seven days whether be allowed to be set up the start time from Sunday to Saturday in sequence. Press “**↕**” to editor the states and working time. “0” means not allowed, “1” means allowed. This left figure means that the water meter will start the batch controller at 08:52 automatically on Tuesday and Saturday.



M34 Set up #T2 batch controller start time

This left figure means that the water meter will start the batch controller at 23:52 automatically on Wednesday and Saturday. (under the enable-control state)



M35 Set up #T3 batch controller start time

This left figure means that the water meter will start the batch controller at 08:52 automatically on Sunday, Wednesday and Saturday. (under the enable-control state)



M36 Set up #T4 batch controller start time

This left figure means that the water meter will start the batch controller at 98:52 automatically on Tuesday and Saturday. But 98:52 is not exist at actual time, this setting is invalid



M37 Set up #T5 batch controller start time

This left figure means there is no setting for everyday,

therefore the batch controller do not work



M38 Display #2 time-accumulator and instantaneous flow or instantaneous heat

On the left figure, decimal point followed "8" means time-accumulator #2 is working, not under closed state, while the time-accumulator #3 is under closed state.

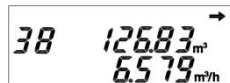

M39 Display #3 time-accumulator and instantaneous flow or instantaneous heat

On the left figure, decimal point followed "9" means time-accumulator #3 is working, not under closed state, while the time-accumulator #2 is under closed state.



M3A Set up #2 and #3 time-accumulator stop time

The left figure means 8:30 am, 12th, January. If the month or date is "0", take an example, '00-00-18:00' only mean 18:00 everyday



M3 B Set up #2 time-accumulator start time

(#3 time-accumulator stop)

The left figure means water meter start time is 18:30 everyday



M3C Set up #3 time-accumulator start time

(#2 time-accumulator stop)

The left figure means water meter start time is 00:30 everyday.



5. How To

5.1 How to modify the unit

It should be modified by the customized parameter software

Flow cumulative unit: m³, ft³, GAL, L.

Instantaneous flow unit: m³/h, GPM, L/m.

Heat cumulative unit: KWh, GJ, kBTU

Instantaneous heat unit: kW, GJ/h, kBTU/h

In future, we will add the unit Acre feet and Refrigeration Ton

5.2 How to modify the cumulative flow of the decimal point position

It can be modified by the special parameter setting software, the decimal point position of the cumulative flow, can be set from 0 to 7.

5.3 How to reset the time(year, month, date, hour, minute, second and week)

- 1) Press “▲” or “▶”, move to M03 windows
- 2) Press “▲▶”, will enter into M10
- 3) Press “▶”, will enter into M11
- 4) Press“▲▶”, there will be the flashing number of the year location.
- 5) Press“▲” number increased, press“▶”, the flashing number will move to next.
- 6) Repeat the step 5 until the last number modified, press “▶” to finish operation.

If there is any mistakes during the operation, please press “▶▲” to exit editor states, then reenter from step 4.

It is not necessary to modify the week as the water meter will calculate the week automatically. The week setting only be used for the batch controller windows.

5.4 How to judge the water meter works properly(according to the status code to check the problem)

In M04, the first line display the water meter working status code. For the detailed description of these code, please refer to §7.1

If the last 8 digital numbers of status code are “0”, means the water meter works properly.

If there exist the number not “0”, according to the §7.1 to check the specific faults.

5.5 How to operate the calibration windows

There are two kinds of calibration method of TFMW water meter, including the start-stop method and constant-current method

3.1 Start-Stop Method

Start-stop method be defined in the stationary states, start and stop the calibration device(standard water meter) and tested water meter simultaneously, is a calibration method by the measured accumulative flow

Please go to Menu 05, you are no need to operate the keypad during the calibration process. When the static fluid is more than 20 seconds, the left side of the window will display "1"; Then open the valve, "P" will be flashing, means during the calibration process, calibration accumulator to Zero and begin to count immediately. When meet the requirement of accumulative flow value, close the valve, flow will be reduced gradually until the "P" without flashing, it will display "1" when the fluid in stationary states. Finish the above process, you can read out the calibrate value from the accumulator, divide water volume of the standard container, that is the relative error. For the start-stop method, the start duration should be more than 60 seconds each time. The shorter duration, the more relative error caused.

3.2 Constant-Current Method

Constant-current method be defined at the set of flow point, make the calibration device(standard water meter) and tested water meter into stable flow state, is a calibration method by the measured accumulative flow at the same time.

Please go to Menu 05, press "↕" " into constant-current window. the left side of the window display capital letter "C". Constant-current method is no need the static flow. When flow stable, press "➡", calibration accumulator begin to count, lowercase letter "c" will be flashing, when require to stop, press "➡" again.

In the calibration window, second line on the display is average instantaneous flow rate of the calibration period time, rather than the instantaneous flow rate instantly. Its formula is : average instantaneous flow rate= accumulative flow rate of calibration period time ÷ calibration period time. In the constant-current window, press "↕", means exiting and entering into start-stop method window

According to the simulate keypad operation, also can achieve the constant-current method calibration by RS485 or infrared interface. Calibrate accumulator valve and calibrate accumulator operation time can be read out by computer and calculate the relative error automatically, there is the correction factor, which will download to the water meter automatically to realize calibration process automation.

5.6 How to operate the built-in batch controller

Version 51 with the built-in Batch Controller(abbreviated BC), also called irrigation controller. Can set up the time controller automatically or manually, so as to finish the batch water irrigation. Batch controller can be operated by key or serial command.

Batch controller can be operated automatically . It can turn on automatically on a setting time, when finish the batch irrigation, it will turn off automatically.

There are two kinds of timing control method, one is according to the Day and another is Week. For the Week, you can choose at any time from Sunday to Saturday, there are 35 timing point maximum for your selection per week. For the Day, there are 5 timing point for your selection per day, and 150 timing point maximum per month for your selection.

If the batch controller not in use,the enable control should be closed in order to make the OCT 2 for other function.

For the key operation, the time control only be set up according to the Week(time control method).

The batch controller hardware output is realized by OCT2, if connect the solenoid value driver to the OCT 2, it can realize the value on-off.

Setup steps of batch controller start time automatically:

- 1) M31, turn on the batch controller enable-control.
- 2) M32, set up the value, such as 5.00 m³.
- 3) From M33 to M37, set up the start time point.

Setup steps of batch controller start time by keyboard:

- 1) From M33 to M37, setup a time value that does not exist, such as 24:15.
- 2) M32, set up the value, such as 5.00 m³
- 3) M31, turn on the batch controller enable-control
- 4) M30, press “**▲▶**”, to start batch controller manually. In condition of batch controller has started, press “**▲▶**” again, to stop batch controller

In the process of batch controller running, OCT2 output is light on LCD.

5.7 How to modify time point of the time-accumulator

Time-accumulator is to realize the flow accumulation at a set period time, to finish the gradient rate.

Time-accumulator is not only finish the daily flow accumulation in two period cycle function, but also can finish from 1 minute to 1 year period time flow accumulation

Time-accumulator , including TARI2 and TARI3 , is controlled by three time point. The three time point is TARI2 start time, TARI3 start time (TARI2 stopped) and TARI3 stop time.

Three time point format is month-day-hour-minute

If you fill 0 in month or day or fill the non existing month or day, that mean it will work everyday at the hour-minute.

5.8 How to modify the communication address

V51 communication address, is several communication protocol address, also is M-BUS main address, is a single-byte address between 0 and 255

Factory default is "1" of this address, this address can be modified by infrared or RS485, also can be modified by keypad.

Modification step by keypad:

- 1) Move to M03(display the calendar)
- 2) press modified key "▲➡", there is a password windows(if operate again within 2 hours, will display the step 4 directly)
- 3) input password "1111", end the last flashing number, will enter into M10.
- 4) Press key "➡" 3 times, will enter into M13, display secondary address and main communication address.
- 5) Press"▲➡", there will be flashing number on the second line of screen.
- 6) Press "▲" to increase the value of digital, or press "➡" to move the cursor to next character , enter the new address.
- 7) Input the last number, that finished.

5.9 How to reset the secondary address of M-BUS

M-BUS secondary address is suitable to be used with M-BUS communication protocol, according to the secondary address, can search devices on the bus by PC software automatically, and main address rearrangement.

The secondary address and serial number are the same and can be modified.

If want to modify the secondary address, the modification of the secondary address can be made by M-BUS communication

When modify the secondary address, if the new address be set up to 00000000, that means the new address is same with ESN.

5.10 How to modify the infrared communication rate

It can be modified the communication rate permanent according to special parameter setting software.

If be modified temporary, also can according to the M-BUS baud rate command , more detailed information please refer to the M-BUS communication protocol.

5.11 How to modify communication rate of RS485/M-bus

It can be modified the communication rate permanent according to special parameter setting software.

If be modified temporary, also can according to the M-BUS baud rate command , more detailed information please refer to the M-BUS communication protocol.

6. Communication

6.1 Communications and Networking

TFMW-1 can achieve short distance wireless communication by connecting RF communication module. Using RF radio frequency, Wireless meter reading with handheld data setter and wirelessGPRS module connection are also available in order to achieve large-scale, far-distance networking.



7.Fault Handling

7.1 Fault Handling

Error code displayed on MOA.

MOA, the left digits on the upper line, is the signal strength and range from 0-9.

The remaining 8 hexadecimal digits is the error code, the meaning of the code as following.

X XX XX XX XX

				BIT0	Heat totalizer error
				BIT1	T1 temperature transducer error
				BIT2	T2 temperature transducer error
				BIT3	Flow meter error
				BIT4	Reverse flow direction
				BIT5	Poor signal strength
				BIT6	Slow work condition, means flow meter be in static fluid or empty pipe more than 2 hours
			BIT0	ERR_CH1	Channel 1 error, or channel 1 is not set up to enable state
			BIT1	ERR_CH2	Channel 2 error, or channel 2 is not set up to enable state
			BIT2	ERR_BATT	Low battery voltage
			BIT3	ERR_FNEG	Return water temperature lower than supply water temperature error
			BIT4	PT1000_T1_S	T1 transducer short circuit fault
			BIT5	PT1000_T1_O	T1transducer open circuit fault
			BIT6	PT1000_T2_S	T2transducer short circuit fault
			BIT7	PT1000_T2_O	T2transducer open circuit fault
			BIT0	ERR_DELTA_BIT	Time difference detection circuit fault
			BIT1	ERR_DISCHARGE	Time difference capacitance discharge fault
			BIT2	ERR_DCAP_BIT	Time difference capacitance short circuit fault
			BIT3	ERR_7474_BIT	Integrated circuit 74AHC74 fault
			BIT4	ERR_RCVER_BIT	Ultrasonic transceiver circuit fault
			BIT5	ERR_WINDOW_BIT	Ultrasonic receive windows signal fault
			BIT6	ERR_TEMPI_BIT	Temperature detection circuit, constant current fault
			BIT7	ERR_TSW_BIT	Temperature detection circuit, analog switch fault

	BIT0	ERR_FREQ_BIT	CPU low frequency clock or high frequency clock error
	BIT1	ERR_PARITY	Data calibration error in parameters
	BIT2	ERR_ROM	Firmware code calibration error
	BIT3	ERR_EPROM_BIT	EPROM read or write error
	BIT4	PT1000_S1_S	Temperature measurement circuit low-end, reference resistor short circuit fault
	BIT5	PT1000_S1_O	Temperature measurement circuit low-end, reference resistor open circuit fault
	BIT6	PT1000_S2_S	Temperature measurement circuit high-end, reference resistor short circuit fault
	BIT7	PT1000_S2_O	Temperature measurement circuit high-end, reference resistor open circuit fault

0~9 is the ultrasonic signal strength. 0 indicates no signal and 9 being the most. This value is effective only when pipe with full liquid and water meter powered on after 1~ 2 minutes.

For the dual channel, it will display two channel signal strength alternative.

In general, it means no error if the last eight digits is "0"; it need to "decode" according to the above table to check the fault if the last eight numbers appears none "0"

For example, "40000100" means fault in channel 1, "40000200" means fault in channel 2, "00000304" means fault in both channel

For example, "40000A006" means open circuit for both temperature transducer, the similar false default will appear when treat the flow meter as heat meter without the temperature transducer.

If you are familiar with the Hexadecimal encoding , It's easy to find out the fault. Also you can download the software "V49_ERRCODE.EXE" to get the meaning of the error from our company website



İMES Sanayi Sitesi B Blok 204. Sk. No:40
Y. Dudullu Ümraniye - İstanbul

Phone: 0216 540 7300

Fax: 0216 540 7303

www.aktek.com.tr info@aktek.com.tr