



QUANTUM³

INSTRUCTION MANUAL

QUANTUM³ (SECOND EDITION REV 3)

February 2020

Part Number M-142-Q-F02-2P

COPYRIGHT

© Pulsar Process Measurement Limited, 2001- 20. All rights reserved. No part of this publication may be reproduced, transmitted, transcribed, stored in a retrieval system, or translated into any language in any form without the written permission of Pulsar Process Measurement Limited.

WARRANTY AND LIABILITY

Pulsar Process Measurement Limited guarantee for a period of 2 years from the date of delivery that it will either exchange or repair any part of this product returned to Pulsar Process Measurement Limited if it is found to be defective in material or workmanship, subject to the defect not being due to unfair wear and tear, misuse, modification or alteration, accident, misapplication or negligence.

DISCLAIMER

Pulsar Process Measurement Limited neither gives nor implies any process guarantee for this product and shall have no liability in respect of any loss, injury or damage whatsoever arising out of the application or use of any product or circuit described herein. Every effort has been made to ensure accuracy of this documentation, but Pulsar Process Measurement Limited cannot be held liable for any errors.

Pulsar Process Measurement Limited operates a policy of constant development and improvement and reserve the right to amend technical details as necessary.

The Quantum³ unit shown on the cover of this manual is used for illustrative purposes only and may not be representative of the actual Quantum³ unit supplied.

COMMENTS, SUGGESTIONS AND TECHNICAL ENQUIRIES

Please contact Pulsar Measurement if you have any comments, suggestions or if you require technical support using the information below:

UK Office

Pulsar Process Measurement Ltd.
Cardinal Building
Enigma Business Centre
Sandy's Road
Malvern
Worcestershire
WR14 1JJ
United Kingdom

Canada Office

Greyline Instruments Inc.
16456 Sixsmith Drive
Long Sault
ON
K0C 1P0
Canada

USA Office

Greyline Instruments Inc.
11451 Belcher Road South
Largo
FL 33773
USA

Tel: +44 (0) 1684 891371
Fax: +44 (0) 1684 575985

Tel: 613-938-8956
Toll Free: 855-300-9151
Fax: 613-938-4857

Tel: 315-788-9500
Tax Free: 888-473-9546
Fax: 315-764-0419

Website:

www.pulsar-pm.com

General Information email:
info@pulsar-pm.com

Technical Support email:
support@pulsar-pm.com

Website:

www.greyline.com

General Information email:
info@greyline.com

Technical Support email:
service@greyline.com

Website:

www.greyline.com

General Information email:
info@greyline.com

Technical Support email:
service@greyline.com

Contents

Chapter 1 Start Here.....	1
About this Manual.....	1
Tips.....	1
Additional Information.....	1
References.....	1
About the Quantum ³ Pump Controller.....	2
Functional Description.....	2
Product Specification.....	4
EU Declaration of Conformity.....	6
Chapter 2 Installation.....	7
Power Supply Requirements.....	7
Location.....	7
Dimensions.....	8
Terminal Connection Details.....	10
Power.....	10
Transducer.....	10
FlowPulse.....	12
Relay Outputs.....	15
Current Outputs.....	15
Digital Inputs.....	15
RS232 Serial Interface.....	15
Fuse Location.....	16
Preparation for Operation.....	18
Maintenance.....	18
Chapter 3 How To Use Your Quantum ³	19
Operating the Controls.....	19
Display.....	19
Run Mode.....	20
Program Mode.....	21
How to Access Program Mode.....	21
Hot Keys.....	22
Menu Keys.....	23
Numeric Keys.....	23
Test Mode.....	26
Using the RS232 Serial Interface.....	27
Parameter Defaults.....	28
Factory Defaults.....	28
Chapter 4 Quick Start Guide.....	29
Quick Setup Menu.....	31
Example 1 Level Control.....	36
Example 2 Sump Control (pump down).....	38
Chapter 5 Parameter Guide.....	41
Menu System Diagrams.....	41
Top Level Menu.....	41
Application Menu.....	42
Relays Menu.....	43
Pump “Advanced” Menu.....	44
Digital Inputs Menu.....	45
Float Switch Backup.....	46
Tariff Guard Menu.....	47

Data Logs Menu	48
FlowPulse.....	49
Pumped Volume Menu	50
Efficiency Menu	51
Display Menu	52
mA Output 1 Menu	53
mA Output 2 Menu	53
Compensation Menu	54
Stability Menu.....	54
Echo Processing Menu.....	55
System Menu	56
Device Comm Menu	57
Test Menu	58
Chapter 6 Parameter Listing and Description.....	59
Application Parameters	59
Operation.....	59
Dimensions	60
Relay Parameters	63
Alarms.....	65
Pumps.....	77
Control.....	82
Miscellaneous	89
Pump by Time	91
Common Parameters	94
Pump Trips.....	94
Pump "Advanced" Parameters	96
Pump Run On	96
Starting	96
Stopping	97
Pump Exercising.....	97
Wall Cling.....	98
Storm.....	98
Rate Method.....	99
FlowPulse	99
Derived Flow	99
Digital Inputs	100
About Digital Inputs	100
Common Parameters Set-up.....	100
Input Type.....	100
Input Function.....	101
Device Fail.....	102
Duty	103
Override.....	106
Reset	106
Digital Input Parameters.....	106
Common Par.....	106
Digital Input	109
Float Switch (FS) Backup.....	111
About Float Switch Backup.....	111
Common Par.....	111
Tariff Guard	112
Set Up.....	112
Peak Times.....	113
Data Log Parameters	115
Totaliser Audits.....	115
Temperature	115

Pump Logs.....	116
FlowPulse	118
General	123
FlowPulse Setup	124
Pumped Volume.....	128
Set Up.....	128
Volume.....	129
Conversion.....	129
Breakpoints.....	132
Tables.....	134
Pump Efficiency.....	134
Set Up.....	134
Display Parameters.....	137
Options.....	137
Failsafe.....	139
Auxiliary.....	140
Totaliser.....	142
mA Output 1 Parameters.....	143
Range.....	143
Operation.....	143
Setpoint.....	144
Limits.....	144
Trim.....	145
Failsafe.....	145
mA Output 2 Parameters.....	146
mA2 Range.....	146
mA2 Operation.....	146
mA2 Setpoint.....	147
mA2 Limits.....	147
mA2 Trim.....	148
mA2 Failsafe.....	148
Compensation Parameters.....	149
Offset.....	149
Temperature.....	149
OVF Persist.....	149
Velocity.....	150
Stability Parameters.....	150
Damping.....	150
Indicator.....	150
Rate.....	150
Filters.....	151
Echo Processing Parameters.....	152
Transducer Status.....	152
DATeM Parameters.....	154
System Parameters.....	155
Passcode.....	155
Backup.....	155
System Information.....	156
Date & Time.....	157
LED Colour.....	157
Watchdog.....	158
Daylight Saving Time.....	159
Device Comm.....	163
RS232 Set Up.....	163
RS 485 Set Up (Optional).....	163
Remote Alarm.....	163

Test Parameters.....	165
Simulation.....	165
Hardware.....	167
Chapter 7 Troubleshooting.....	169
Chapter 8 Disposal.....	171
Notes	172

Chapter 1 Start Here

Congratulations on your purchase of a Pulsar *ultra* Quantum³ Pump Controller. This quality system has been developed over many years and represents the latest in high technology ultrasonic level measurement and control.

It has been designed to give you years of trouble-free performance, and a few minutes spent reading this operating manual will ensure that your installation is as simple as possible.

About this Manual

It is important that this manual is referred to for correct installation and operation.

There are various parts of the manual that offer additional help or information as shown:

Tips



TIP

At various parts of this manual you will find tips to help you.

Additional Information

Additional Information

At various parts of the manual, you will find sections like this that explain specific items in more detail.

References

— See Also

References to other parts of the manual

About the Quantum³ Pump Controller

The Quantum³ is a state of the art pump management, and level controller, that provides advanced operating routines suitable for an extremely wide variety of applications. The system combines premium specification with high performance even in the most arduous applications where high turbulence and foam or froth is present.



Functional Description

The Quantum³ level and pump controller is a highly developed ultrasonic level measurement system which provides non-contacting sophisticated pump and level control routines suitable for an extremely wide variety of applications.

Easy calibration and maintenance free “fit and forget” performance mean that you can install the Quantum³ pump controller rapidly and with confidence. Ten user-definable relays with adjustable, individual on and off points. Seven user-definable digital inputs, 2 x isolated mA output, RS 232 and intelligent performance logging software features provide the user with a superior pump management system and comprehensive level measurement information.

The Quantum³ operates on the principle of timing the echo received from a measured pulse of sound transmitted in air and utilises the unique DATEM software (Digital Adaptive Tracking of Echo Movement).

This is an entirely new digital mapping technique developed especially for the Pulsar *ultra* range. It gives the system the edge when identifying the “true target level” in the face of competing echoes from pipes, pumps or other obstructions. When coupled with the powerful, long range abilities of all the dB transducer range, including the new dBR16 mmWave radar, the Quantum³ level and pump controller has no equal.

The Quantum³ can measure from zero to 50m from the transducer to the surface being monitored, dependent on the transducer used.

The Quantum³ can show **level, space and distance** on the display. The relays can be programmed to activate alarms, pump starters, or other control equipment. In addition the digital inputs can be used to modify pump and control regimes in order to optimise performance. There are two isolated 4-20 mA outputs that can be connected to a chart recorder or PLC, to monitor level, space, distance, or pumping rate, independently from that shown on the display. There is an RS232 port, so that the Quantum³ can be operated remotely by a PC or other equipment.

The Quantum³ can interface with up to four Pulsar FlowPulses. This gives the Quantum³ the ability to measure flow in real time.

The Quantum³ is programmed by the built-in keypad or by PC via the RS 232 Serial Interface (optional). All the parameters are stored in non-volatile memory, so are retained in the event of power interruption. A second backup copy of all parameters can also be retained in the Quantum³, in case a previous set of parameters needs to be restored.

Product Specification

Physical

Fascia Mount	
Outside dimensions	200 x 112 x 108
Weight	Nominal 1.3kg
Enclosure material/description	Stainless steel with Polycarbonate UL94 -V0 front and bezel
Transducer cable extensions	2-core screened
Maximum separation	1000 m (500m for dB16)

Environmental

IP Rating (fascia mount)	IP64
Max. & Min. temperature (electronics)	-20 °C to +50 °C
Flammable atmosphere approval	Safe area: compatible with approved dB transducers (see transducer spec' sheet)
CE approval	See EU Declaration of Conformity

Performance

Accuracy	0.25% of the measured range or 6 mm (whichever is greater)
Resolution	0.1% of the measured range or 2 mm (whichever is greater)
Max. range	Dependant on transducer (maximum 40m dB40)
Min. range	Dependent upon transducer (minimum zero dB Mach 3)
Rate response	Fully adjustable

Echo Processing

Description	D A T E M (D igital A daptive T racking of E cho M ovement)
--------------------	-------------------------------------------------------------------------------------------------------------------------

Outputs

Analogue output	2 off Isolated (floating) outputs (to 150V) of 4-20 mA or 0-20 mA into 500Ω (user programmable and adjustable) 0.1% resolution
Digital output	Full Duplex RS232 +
Volt-free contacts, number and rating	5 form "C" (SPDT) rated at 5A at 115V AC (Relays 1, 2, 3, 4, & 5) 5 form "C" (SPDT) rated at 3A at 115V AC (Relays 6, 7, 8, 9 & 10)
Display	6 digits plus 12-character text, plus bar graph with direction indicators, remote communicator identifier, and program/run/test mode indicators
FlowPulse Power	24V DC to power up to 4 FlowPulses
FlowPulse Comms	RS485 for communicating with up to 4 FlowPulse

Digital Inputs

Min. Input Voltage 4.5VDC

Max. Input Voltage 30VDC (Max Current 3mA)

24VDC Input Supply maximum total current 24mA.

Programming

On-board programming

By integral keypad
via RS232

PC programming

Programming security

Via passcode (user selectable and adjustable)

Programmed data integrity

Via non-volatile RAM, plus backup

Supply

Power supply

85 – 264V AC 50/60Hz

DC 22 - 28V

25W maximum power

Fuses

2A 'T' 20mm fuse

Pulsar Process Measurement Limited operates a policy of constant development and improvement and reserve the right to amend technical details as necessary.

EU Declaration of Conformity



EU DECLARATION OF CONFORMITY

P U L S A R Ultra Fascia Mount

This declaration of conformity is issued under the sole responsibility of the manufacturer

Relevant Directive(s)	2014/30/EU - EMC Directive and its amending directives 2014/35/EU - Low Voltage Directive and its amending directives 2011/65/EU - RoHS Directive and its amending directives
Manufacturer's Name	Pulsar Process Measurement Ltd
Manufacturer's Address	Cardinal Building, Enigma Business Commercial Centre, Sandy's Road, Malvern, Worcestershire, WR14 1JJ, UK
Apparatus	Pulsar Ultra Fascia including Quantum, Zenith, Ultra 3 & 5, dB Transducer series
Type of Equipment	Measurement and process control
Standards Applied	EN 61010-1 Safety requirements for electrical equipment for measurement, control, and laboratory use EN 61326-1:2013 Equipment class, industrial

Signed  Name: Jeff Allan (BSc.) Engineer Pulsar Process Measurement Ltd	Date: 20 th June 2017 Rev 4.0
-------------------------------------------------------------------------------------------------------------------------------------------------------------------------	------------------------------------------------

Power Supply Requirements

The Quantum³ can operate from AC supply or from a DC battery. The AC is 85 – 264V AC 50/60Hz. The DC is 22-28V.

Location

All electronic products are susceptible to electrostatic shock, so follow proper grounding procedures during installation.

The Quantum³ Pump Controller and FlowPulse must be mounted in a non-hazardous (safe) area, and the transducer can be fitted in a hazardous area.

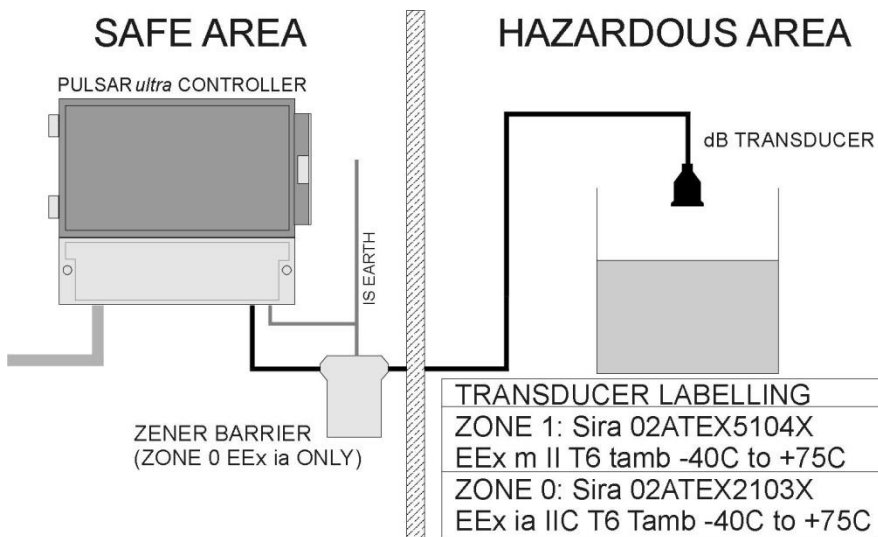

When choosing a location to mount the enclosure, bear in mind the following:

- Ensure that the **Quantum³** is installed in a “Safe”, non-hazardous, area.
- For a clear view of the LCD display it is recommended that you mount it at eye level.
- The mounting surface is vibration-free.
- The ambient temperature is between -20°C and 50°C.
- There should be no high voltage cables or inverters close by.

Dimensions

The Quantum³ should be installed by cutting a hole in the panel as detailed below.

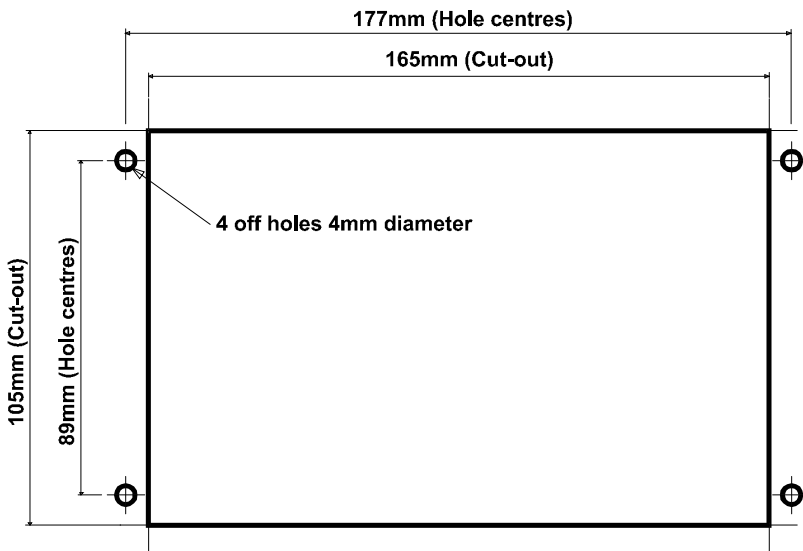

The full dimensions of the enclosure are as shown below.

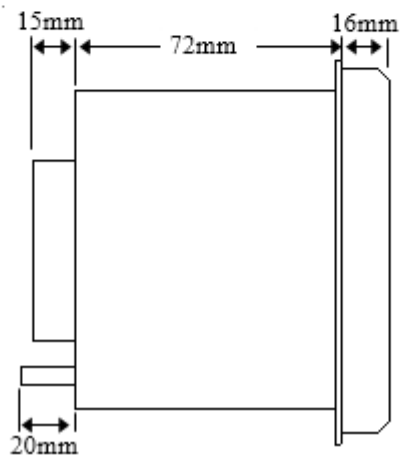
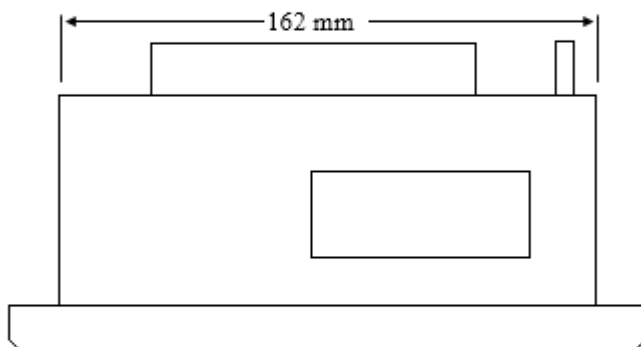
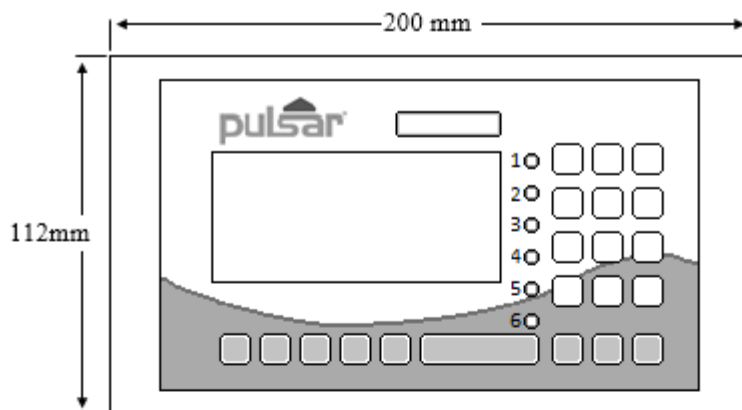

Terminal Connection Details

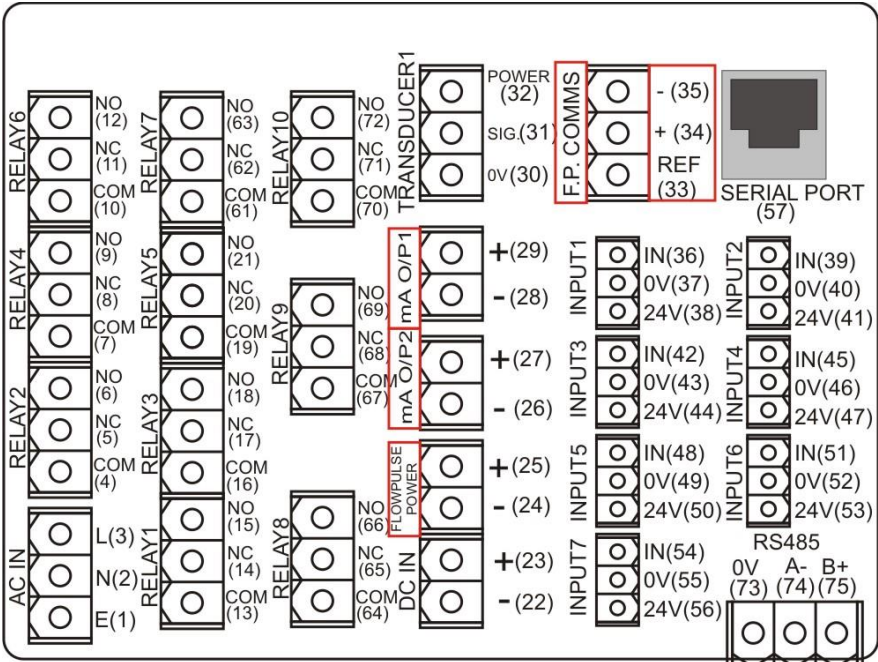

Power

The Quantum³ can operate from mains AC and automatically from DC or battery backup in the event of power failure or can be operated permanently from DC or batteries.

Transducer

The transducer should be installed, and connected, in accordance with the installation instructions contained in the Transducer User Guide.

Wire the transducer to the Quantum³ transducer terminals, as follows:

Transducer

Terminal Connection Details			
Red Power	White Signal	Black 0 volts	Green Screen
32	31	30	30

When using 2-core screened extension cable, the Black and Green wires of the transducer should be connected to the screen of the extension cable, which in turn should be connected to the appropriate 0 volt terminal of the Quantum³.

ATEX

For **EEx m (Zone 1)** applications a transducer certified to **Sira 02ATEX5104X** is used, and must be supplied via a 4000A breaking fuse, which is fitted as standard to the *Quantum*³.

For **EEx ia (Zone 0)** a transducer certified to **Sira 02ATEX2103X** is used, which must be connected to the *Quantum*³ via an external Zener barrier.

FM

For **EEx m (Zone 1)** applications a transducer certified to **FM Class I Div 1 Group A, B, C & D, ClassII Div 1 Group E, F & G, Class III** is used, and must be supplied via a 1500A breaking fuse, which is fitted as standard to the *Quantum*³.

Restrictions do not use in the presence of these groups of Chemicals, Aliphatic Hydro Carbons, Ketones or Esters

For **EEx ia (I.S.)** a transducer certified to **FM Class I Div 1 Group A, B, C & D, ClassII Div 1 Group E, F & G** is used, which must be connected to the *Quantum*³ via an external Zener barrier.

See transducer label for certification details.

FlowPulse

When using the FlowPulse sensor, please use the FlowPulse manual for specifics on how and where to setup the FlowPulse.

Flow pulse units are connected to a Quantum³ via a 5-core screened cable.

The cable screen should be connected to mains earth at the Quantum³ end only.

The wiring of the Flow Pulses should follow either wiring option 1 or 2.

You can connect 1 to 4 Flow Pulse units to the Quantum³.

The extreme ends of the Modbus cabling should be terminated with a 120R resistor (this is achieved in FlowPulse via the termination switch). If termination is required at the Quantum³ fit the included 120R resistor across terminals 34 & 35.

The spurs to the FlowPulses should be kept as short as possible.

Wiring detail:

Description	Quantum ³	Flow Pulse 1	Flow Pulse 2	Flow Pulse 3	Flow Pulse 4
Flow Pulse Power 24VDC	25	1	1	1	1
0V	24	2	2	2	2
FlowPulse comms +	34	9	9	9	9
FlowPulse comms -	35	10	10	10	10
Return	33	8	8	8	8

Important Information

Termination – see following drawings.

Wiring Option 1- Switch on the termination of the last FlowPulse and fit 120R resistor (supplied) across terminals 34 & 35 of the Quantum³.

Wiring Option 2 – Switch on the termination of the FlowPulses at the extreme ends i.e. FlowPulse 2 & 4.

QUANTUM 3 Flow Pulse wiring option 1

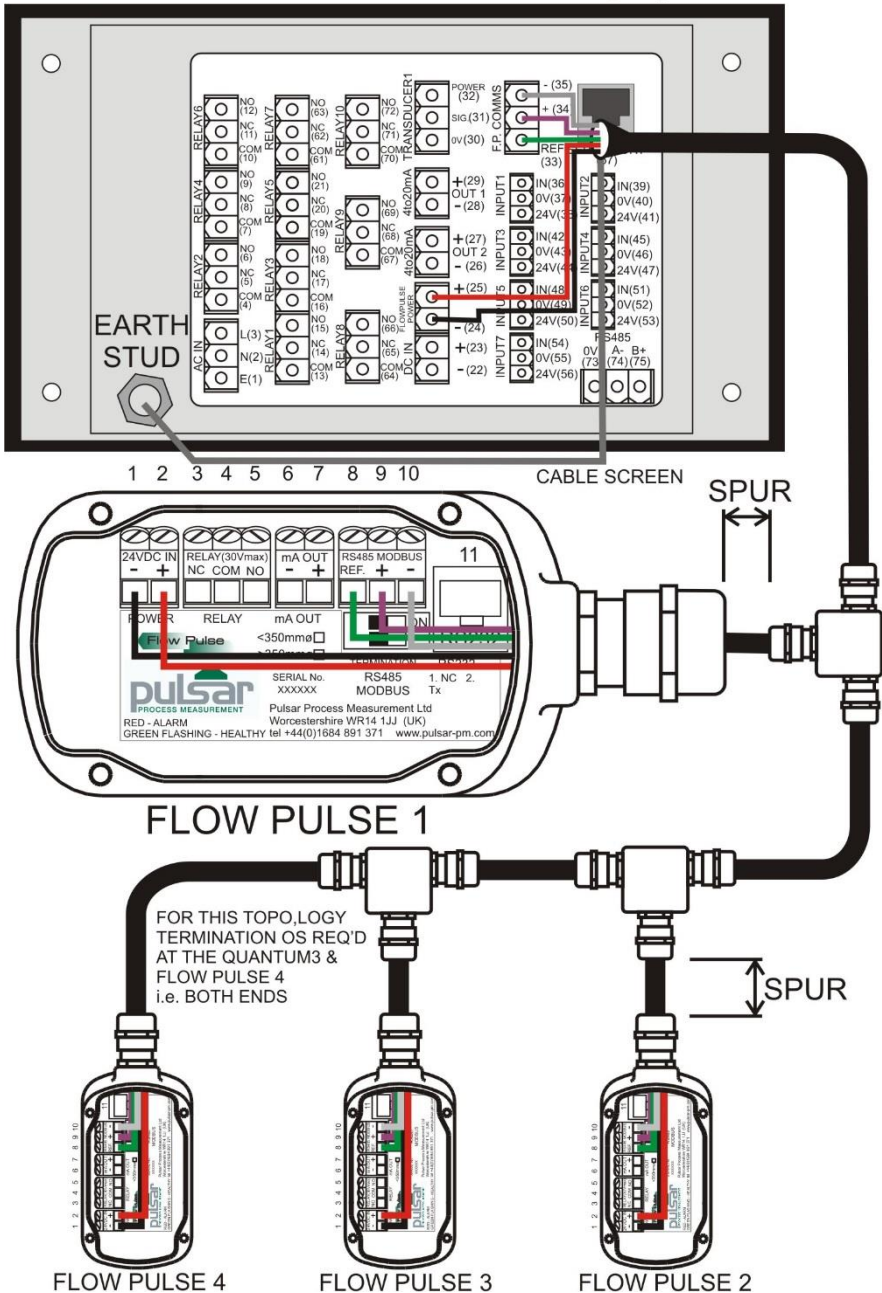

QUANTUM 3 Flow Pulse wiring option 2

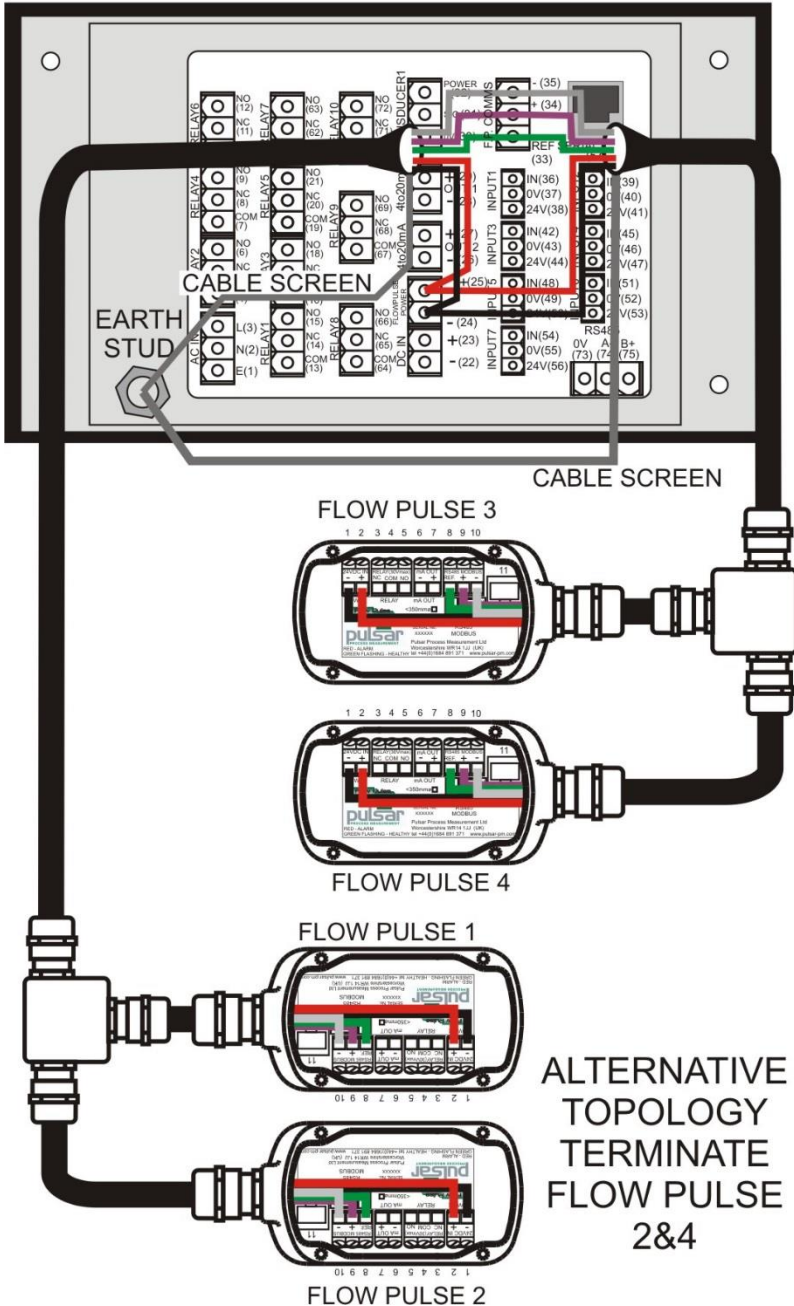

Relay Outputs

The ten user definable relays can be programmed for a variety of alarms, pump control, or other process functions. Relays 1, 2, 3 4 and 5 contacts are all rated at 5A at 115V AC, whilst Relay 5, 6, 7, 8, 9 and 10 contacts are rated at 3A at 115V AC. All connections should be such that the short circuit capacity of the circuits to which they are connected, is limited by fuses rated so that they do not exceed the relay rating.

Current Outputs

These are isolated (floating) mA outputs (to 150 V), of 4 - 20mA or 0 - 20mA and the load should not exceed 500 Ω .

Digital Inputs

Where the Quantum³ is required to provide power for a Device Input the appropriate Digital Input should be wired between the 24VDC supply terminal and the IN terminal. (TOTAL maximum current available, for all seven digital inputs, from the 24VDC supply is 24mA). When Device Inputs are self-powered, connection of the device should be made between the Common terminal and the IN terminal. (Min Input voltage 4.5VDC, and Maximum Input voltage 30VDC with a maximum current of 3mA).

RS232 Serial Interface

If required, you can connect to the serial interface, to operate your Quantum³ remotely.

Fuse Location

The mains fuse is located under the removable cover at the bottom of the unit, as illustrated below.

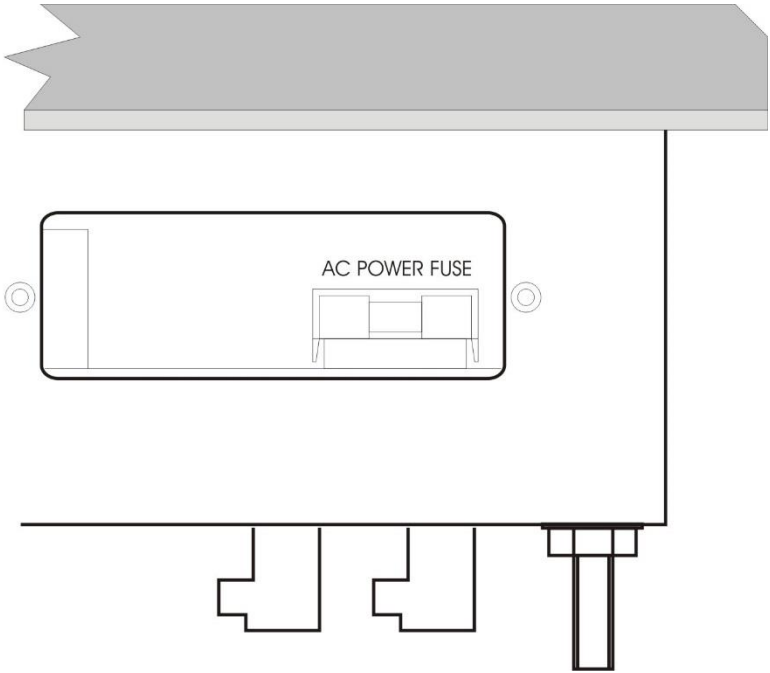

Important Information

The rear metal case of the fascia unit must be connected to earth via the earthing stud located on the rear of the unit, see drawing above, using wiring to meet local requirements.

An external switch or circuit breaker should be installed near to the Quantum³ to allow the supply to be removed during installation and maintenance. In addition, the relay contacts should also have a means of isolating them from the unit.

Interconnecting cables must be adequately insulated in accordance with local regulations. Strip back 30 mm of the outer insulation of the cable. Strip 5 mm of insulation from the end of each conductor. Twist all exposed strands of the conductor together. Insert the stripped conductor into the terminal block as far as it will go and tighten the terminal block screw. Ensure that all strands are firmly clamped in the terminal block and that there is no excess bare conductor showing, and no stray strands.

Important Information

If the equipment is installed or used in a manner not specified in this manual, then the protection provided by the equipment may be impaired.

Preparation for Operation

Before switching on, check the following:

- ✓ The Quantum³ is mounted correctly and is in a 'safe' area.
- ✓ The power supply is correctly installed.
- ✓ The relays are connected correctly.

Maintenance

There are no user serviceable parts inside your Quantum³, except the mains fuse. If you experience any problems with the unit, then please contact Pulsar Process Measurement for advice.

To clean the equipment, wipe with a damp cloth. Do not use any solvents on the enclosure or front panel.

Important Information

The unique DATEM software comes into operation as soon as power is applied and is designed to monitor a **moving level** or **target** with the **transducer** in a **fixed position**.

If, after any period of use, it should become necessary to move the transducer, for any reason, from its original operating position, switch off the **Quantum³**, before proceeding, to prevent any undesirable updates to the **DATEM** trace. If after moving the transducer the reading is not as expected, please refer to **Chapter 6 Troubleshooting**.

Quick Setup

If you are already familiar with the controls of the Quantum³, go straight to the quick setup guide in Chapter 4.

Operating the Controls

Display

The display provides information on the current mode of operation, and status of the remote communication. Whilst in the Run Mode it will display the current level reading and its units of measure, along with status messages with regards to the Transducer, Echo reception and Fail Safe Mode. Additionally, it can be programmed to provide status messages on alarms, pumps etc. When in the Program Mode the display is used to read information on the Menu System, Parameter Number and parameter details and values, which can be entered. During Test Mode the display is used to monitor the simulated level. A bar graph is also provided which will provide a visual reading of the level, in percentage of span.

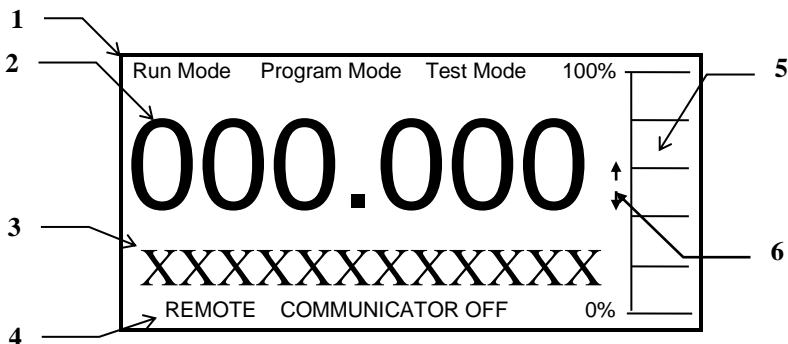

- 1) Mode status enunciator displays the current mode of operation.
- 2) Main 6-digit display:
 - Run Mode** - current measurement displayed, dependent on mode and measurement unit's chosen, and value of Hot Key function selected.
 - Program Mode** - displays parameter number and values entered for parameters.
 - Test Mode** - displays simulated level.
- 3) Auxiliary Display (scrolling twelve digit display)
 - Run Mode** - displays measurement units (P104), status messages on signal and transducer and detail of Hot Key function selected. It can also be programmed to provide notification messages on alarms, pumps etc. (For full details please refer to **Display Parameters** in Chapter 5.)
 - Program Mode** - displays Menu and Sub Menu headings, parameter details and options.
- 4) Communicator status enunciator displays the current status of optional remote PC connection.
- 5) Bargraph display gives visual indication of measurement in % of span.
- 6) Level indicators
 - Run Mode** - indicates in which direction the level is moving.
 - Program Mode** - indicates at which level, of the menu system, you are currently at.

There are two main operating modes for your **Quantum³**, **Run Mode** and **Program Mode**. There is also a **Test Mode**, used for checking the set-up. All modes are now described.

Run Mode

This mode is used once the **Quantum³** has been set up in program mode. It is also the default mode that the unit reverts to when it resumes operation after a power failure.

When the **Quantum³** is switched on for the first time, it will display, in metres, the distance from the transducer face to the target. All relays by default are switched off.

After programming is complete, any relays that are set will operate when the level reaches the relevant setpoint, and, in the case of relays 1, 2, 3, 4, 5 and 6, the LED's will change colour (unless specifically switched off).

Program Mode

This mode is used to set up the **Quantum³** or change information already set. You must use either the built-in keypad (standard) or alternatively the unit can be set up with a PC via the RS 232 Serial Interface (optional).

Entering a value for each of the parameters that are relevant to your application provides all the programming information.

How to Access Program Mode

To enter **program mode**, you simply enter the passcode, via the keypad, followed by the ENTER key. The **default passcode** is **1997**, so you would press the following:









Note

There is a time-out period of 15 minutes when in **program mode**, after which time **run mode** will be resumed if you do not press any keys.





Hot Keys

There are five hot keys on the keypad, which can be used to quickly access common parameters for viewing only, while in Run Mode. Pressing the hot key once will display the first parameter, then repeated pressing will display the others, after which the Quantum³ reverts to Run Mode. In Program Mode, they have different functions, the functions are shown below.

Hot Key	Run Mode	Program Mode
	Total pump running hours, and individual pump running hours.	Not used with Quantum ³ .
	Displays echo confidence, echo strength, H.A.L.L., average noise, peak noise or temperature.	Not used with Quantum ³ .
	Total number of pump starts, and individual pump starts.	Reset parameter to default setting.
	Instantaneous mA output.	Not used with Quantum ³ .
	Dependant on application displays Distance, Level, Space, Volume or rate of change of level.	Toggle relay setpoints between Quantum ³ 's units of measure and % of span.
	Reset for Digital Inputs	Takes you to the last parameter edited, when you first enter program mode.
	Gives details of unit type, software revision and serial number.	Enter decimal point

Menu Keys

The menu keys are used to navigate around the built-in menu system and have the following functions:

Menu Key	Function
 	1) Arrow keys for moving left and right around the menu system. 2) Used in test mode to simulate the level moving up and down.
	1) Used to confirm each action (for example select a menu option) or when entering a parameter number or value. 2) Used to confirm questions asked by your Quantum ³ such as before restoring factory defaults.
	Used to navigate up a level in the menu system, and back to run mode. Used to cancel a value entered in error.

Numeric Keys

These keys are used for entering numerical information during programming.



There are two means of editing parameters; directly or using the menu system. Each is now described below.

Using the Menu System

The menu system has been designed to make the changing of parameters very simple. There are two levels of menu: **Main Menu** and **Sub Menu**.

On the display there is a line of text that displays the menu system. Pressing the arrow keys scrolls the display between the top-level menu items, as show below in the “Quick Setup”.

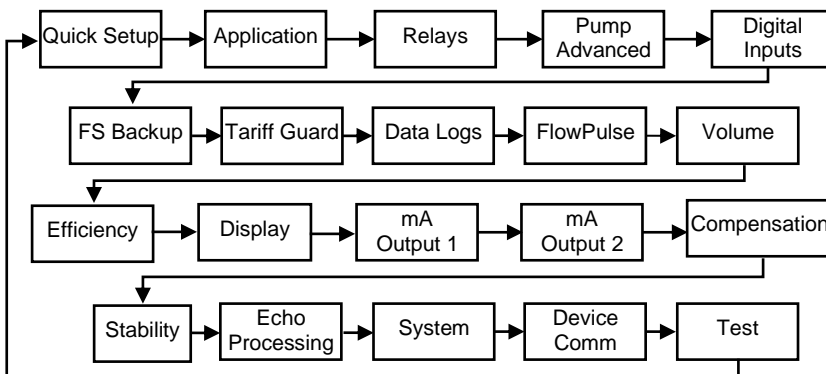

As you press the cursor keys to scroll left and right, between these you can press **ENTER** at any time to select it and take you to the sub-menu.

Each of these options, along with their sub-menus are described in Chapter 5, Error! Reference source not found.. When you move down into the sub-menu, you can scroll round using the arrow keys, and press **ENTER** to go to the required section of parameters.

Once you have reached the relevant section, scroll through the parameters, and enter the necessary information. To enter the information, use the numeric keys and press **ENTER** when you will see the message “**Saved!**” If you press **CANCEL**, then the change you made will not be saved, and the message “**Unchanged!**” will be displayed.

When you have finished, press **CANCEL** to go back to the previous level. When you have reached the top level, then the **Quantum**³ will ask for confirmation before allowing you to go back into run mode. This is done by pressing **ENTER** at the display prompt.

Note

You can tell which part of the menu system you are in, as the up/down indicators, (arrows) next to the bar graph will indicate as follows:

- **Top level menu: Down arrow on**, to indicate you can move down.
- **Sub-menu: Up and Down arrows on**, to indicate you can move up to the top level, and down to parameter level.
- **Parameter Level: Up arrow on**, to indicate you can move up to sub-menu level.
- **Parameter Editing: No arrows on**.

Directly Editing Parameters

If you already know the number of the parameter that you wish to look at or edit, simply type the number in at any time while you are in the menu system. Thus, if you are in either the menu or sub-menu level, by pressing a numeric key you can enter the parameter number directly and jump straight there. You cannot type a parameter number whilst at parameter level, only at one of the two menu levels.

When you are at a parameter the text line rotates automatically displaying the parameter name, number, the applicable units and the maximum and minimum figure you can enter. The top line shows the value you are setting.

Once you have accessed a parameter you can either just look at it, or change it.

Once a parameter has been changed, press **ENTER** and you will see the message “**Saved!**” If you press **CANCEL**, then the change you made will not be saved, and the message “**Unchanged!**” will be displayed.



TIP

You can jump straight to the last parameter you edited, by pressing '+/-' when you first enter program mode.

Test Mode

Test mode is used to simulate the application and confirm that all parameters and relay setpoints have been entered as expected. During simulation there is a choice of whether the relays will change state (hard simulation) or not (soft simulation), but the LED's will always change colour as programmed, and the mA output will change in accordance to the chosen mode of operation. If you wish to test the logic of the system that the **relays are connected** to then select **hard simulation**, but if you **don't want to change the relay state**, then select a **soft simulation**.

There are two simulation modes, automatic and manual. Automatic simulation will move the level up and down between empty level or the pre-determined **Start Level (P983)** and Pump/Control relay switch points, if you wish to change the direction of the level movement e.g. to go beyond relay setpoints, this can be done by using the arrow keys. In manual simulation, using the arrow keys will allow you to move the level up and down as required.

To enter simulation, first go to **program mode**. Then, using the menu system, select menu item '**Test**', then sub-menu item '**Simulation**'. Simply change the value of the parameter **P980** to one of the following:

- 1= Manual soft simulation
- 2= Automatic soft simulation
- 3= Manual hard simulation
- 4= Automatic hard simulation

To return to program mode, press **CANCEL** and test mode will end.

When in **manual** simulation, by default test mode will move the level by 0.1m steps. Altering the **increment (P981)** will change this value.

In **automatic** mode, the rate at which the level moves up and down is set by be changed to make the level move up and down faster. E.g. if **increment (P981)** is set to 0.1m and **rate (P982)** is set to 1 min then the level will increase or decrease at a rate of 0.1m/min. To make the simulated level move slower, decrease the value in **increment (P981)** or increase the value in **rate (P982)**. To make the simulated level move faster, increase the value in **increment (P981)** or decrease the value in **rate (P982)**.

Whilst in Automatic hard simulation (**P980 = 4**) the switching of digital inputs can be simulated by pressing the corresponding numeric key to the input to be switched, each time the numeric key is pressed it will toggle the input between On and Off.

Using the RS232 Serial Interface

The RS232 serial interface can be used to set up the Quantum³, and obtain information using a PC or other computer equipment. To do so, the settings for control are as follows: baud rate 19,200; 8 data bits; no parity; and 1 stop bit.

The device should be connected via the serial port, as shown in **Chapter 2 Installation**.

To use the device remotely, you need to **log on** to start, and **log off** when finished. When **logged on**, the Quantum³ will show '**Remote ON**' on the display, and "**Communicator OFF**" when **logged off**.

All commands should be followed by a carriage return.

The unit will respond either OK (or a value) if the command is accepted, or NO if it is not. To log on, you send the command

/ACCESS:pppp where pppp is the passcode (P922).

To log off, you send the command

/ACCESS:OFF

To read a parameter value, send the command

/Pxxx where xxx is the parameter you wish to read, and the unit will respond with the parameter value.

To set a parameter, send the command

/Pxxx:yy where xxx is the parameter number and yy is the value you wish to set it to.

Other commands you can use are:

/DISTANCE (shows current distance)

/LEVEL (shows current level)

/SPACE (shows current space)

/VOLUME (shows current volume)

/RATE (shows current rate of change)

/TEMP (shows current temperature)

/CURRENTOUT (show the mA output value)

/CURRENTIN (show the mA input value)

/BACKUP1 (take backup of parameters to area 1)

/BACKUP2 (take backup of parameters to area 2)

/RESTORE1 (restore parameters from area 1)

/RESTORE2 (restore parameters from area 2)

Parameter Defaults

Factory Defaults

Factory Defaults

When first installing the Quantum³, or subsequently moving or using the unit on a new application, before proceeding to program the unit for its intended application it is recommended that you ensure that all parameters are at their default values by completing a **Factory Defaults P930**, as described in Chapter 5 **Parameter Guide**.

When you first switch the Quantum³ on, it will be reading the **distance** from the face of the transducer to the surface (In the case of the mmWave radar the **distance** is from the lens face to the surface). It will be indicating in **metres**, as shown on the display. All relays are set OFF.

The **date** (P931) and **time** (P932) in the Quantum³ were set at the factory, but may need checking, and amending if, for example the application is in a time zone other than GMT, see Chapter 5 **Parameter Guide** for full details.

TIP



In some applications, it is simplest to empty the vessel, take a reading from the Quantum³ for distance and then setup the empty level to this figure.

Once you are satisfied with the installation, and the Quantum³ is reading what you would expect in terms of distance from the face of the transducer to the material level, then you can proceed with programming, for the intended application. It is sensible to program all of the required parameters at the same time. The system will be then set-up.

Note that the span is automatically calculated from the empty level, so the empty level should be entered first.

This quick set-up guide shows you how to get up and running in a few minutes in just four easy steps after installing your Quantum³.

Enter Program Mode

First you need to go from run mode into program mode. Assuming the passcode is the default 1997, then you should enter this.



Choose Quick Setup

Now you need to go into the quick setup. You will see on the menu the words 'Quick Setup', which is the first item on the menu system. Try pressing the two arrow keys to see some more menu options, but return to Quick Setup, and press



This takes you to the common applications parameter (P200).



This takes you to the common applications parameters, and you will see some options appearing on the display.

Note

If you have already setup a common application, then there will be a number shown other than 0, and you will see messages showing what the current setup is. If you want to reset this and start again, press 0 (which will reset all the quick setup parameters), otherwise pressing ENTER will allow you to edit the parameters that have been set.

Choose Your Application

There are four categories of application, which are all described at the end of this chapter. They are **level**, **pump down** (sump control), **pump up** (reservoir control) or **customised**, all with the choice of alarms and a number of pumps, dependant on application.

If you want to set-up a basic **level monitoring** application, as described in the following **example 1**, then choose 1. You then need to decide the **number of alarms** required and their **function** and choose the appropriate options.

If you want to set-up a **pump down** (sump control) application, as described in the following **example 2**, then choose 2. You then need to decide the **number of pumps** required the **pump duty** and any requirement for **alarms** and choose the appropriate options.

If you want to set-up a **pump up** (reservoir control) application, then choose 3. You then need to decide the **number of pumps** required the **pump duty**, and any requirement for **alarms**, and choose the appropriate options.

In certain cases, the Quick Setup Menu has been **customised** for particular customer specific applications, to choose one of these options press 4 and select the appropriate **customised** application and enter the details required as prompted.

Once you have chosen your application you will be asked a series of questions which are answered by choosing the appropriate option as detailed in the flow charts that follow. Once all the questions have been answered you will be prompted to provide further information, as detailed in the tables that follow, in order to complete the programming of the unit.

The Quick Setup Menu detailing the questions you are asked, when setting up your Quantum³, via the Quick Setup is shown below.

Quick Setup Menu

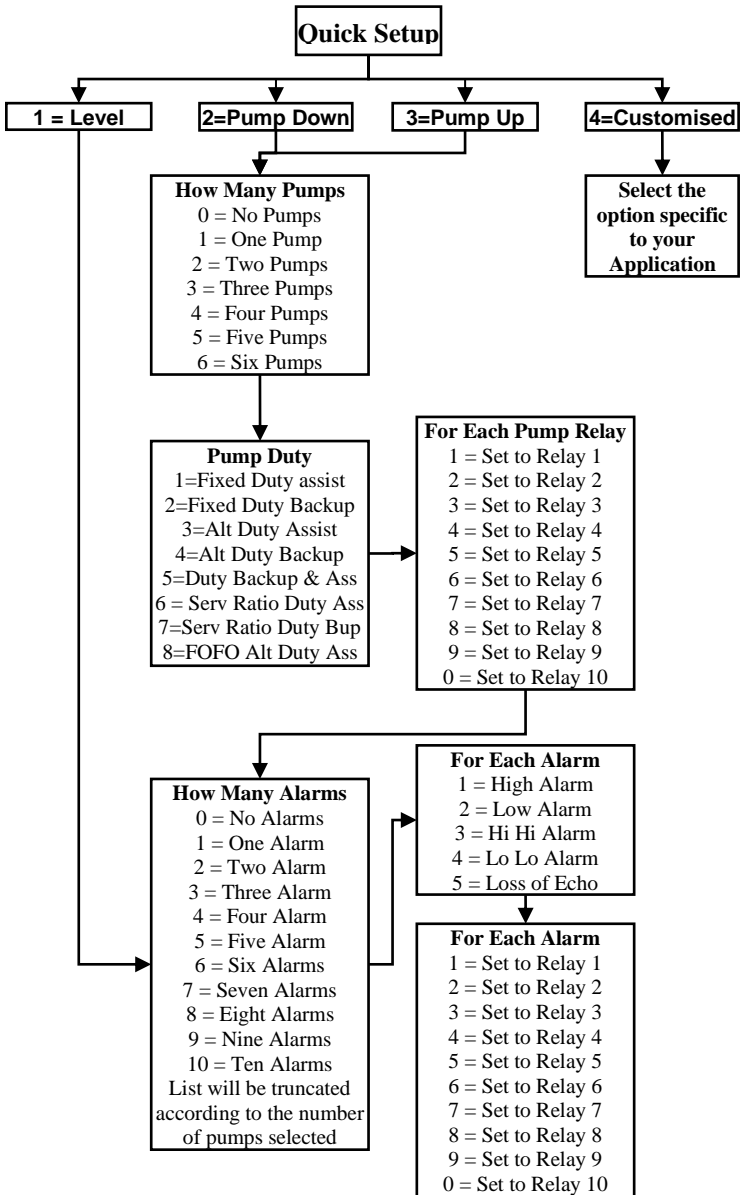

Note

The maximum number of relays that can be allocated, via the Quick Setup, for use as 'alarms' or 'pump' is six, if you require to allocate additional relays to 'alarms or 'pump' this can be achieved by accessing the Relay Menu and programming additional relays as required.

Set-up Your Application

Once you have chosen the application, you will see a '**Wait...**' message while the parameters are all calculated and stored. Next you will see the parameters needed to finalise your application, in turn, as shown below. If you know you don't need to change from the default, you can use the right arrow key to scroll through them, but if you want to view or change each one, just press ENTER.

Parameter	Default	Description
P101 Transducer	2 = dB6	Type of transducer being used.
P104 Measurement Units	1 = metres	Select units to be used for programming measurement information.
P105 Empty Level	6 m	Distance from the face of the transducer to the material at the bottom of the vessel.
P106 Span	5.7 m	Distance from the empty level (0% full) to span (100% full).

For More Options Hit Enter

Now you will see a scrolling message that says 'For more Options **Hit Enter**'. If you press ENTER, you will then see more parameters, specific to the application you have chosen, these are all factory preset. If you press any other key you will return to the Quick Setup menu, where you can press CANCEL to return to run mode.

If you want to change any of the factory preset parameters, then you can do so, referring to the relevant page of Chapter 5, in this handbook for detailed information. The parameters concerned are shown below.

Parameter	Default	Description
P213 / P214 Relay 1 ON/OFF setpoints	Factory preset as a % to appropriate level according to the span already entered. See tables below	Either Alarm or Level control. Depends on application.
P223 / P224 Relay 2 ON/OFF setpoints	Factory preset as a % to appropriate level according to the span already entered. See tables below	Either Alarm or Level control. Depends on application.
P233 / P234 Relay 3 ON/OFF setpoints	Factory preset as a % to appropriate level according to the span already entered. See tables below	Either Alarm or Level control. Depends on application.
P243 / P244 Relay 4 ON/OFF setpoints	Factory preset as a % to appropriate level according to the span already entered. See tables below	Either Alarm or Level control. Depends on application.
P253 / P254 Relay 5 ON/OFF setpoints	Factory preset as a % to appropriate level according to the span already entered. See tables below	Either Alarm or Pump control. Depends on application.
P263 / P264 Relay 6 ON/OFF setpoints	Factory preset as a % to appropriate level according to the span already entered. See tables below	Either Alarm or Level control. Depends on application.
P830 mA Out Range	2= 4 to 20 mA	Determines the mA output range. 0 = Off, 1 = 0 to 20mA, 2 = 4 to 20mA , 3 = 20 to 0mA, 4 = 20 to 4mA.
P870 Fill Damping	10 m/min	Rate of maximum fill rate (set above the <u>actual fill rate of the</u>
P871 Empty Damping	10 m/min	Rate of maximum empty rate (set above the actual empty rate of the vessel).

The default values used for determining the relay setpoints, when setting alarms and pumps, via the Quick Setup menu are entered as a % of span and are as follows.

Application	Number of Pumps	Pump Number	On Setpoint	Off Setpoint
Pump Down	One	Pump 1	50%	20%
Pump Down	Two	Pump 1	50%	20%
		Pump 2	70%	20%
Pump Down	Three	Pump 1	50%	20%
		Pump 2	60%	20%
		Pump 3	70%	20%
Pump Down	Four	Pump 1	40%	20%
		Pump 2	50%	20%
		Pump 3	60%	20%
		Pump 4	70%	20%
Pump Down	Five	Pump 1	40%	20%
		Pump 2	50%	20%
		Pump 3	60%	20%
		Pump 4	70%	20%
		Pump 5	75%	20%
Pump Down	Six	Pump 1	40%	20%
		Pump 2	50%	20%
		Pump 3	60%	20%
		Pump 4	70%	20%
		Pump 5	75%	20%
		Pump 6	80%	20%

Application	Number of Pumps	Pump Number	On Setpoint	Off Setpoint
Pump Up	One	Pump 1	50%	80%
Pump Up	Two	Pump 1 Pump 2	50% 30%	80% 80%
Pump Up	Three	Pump 1 Pump 2 Pump 3	50% 40% 30%	80% 80% 80%
Pump Up	Four	Pump 1 Pump 2 Pump 3 Pump 4	60% 50% 40% 30%	80% 80% 80% 80%
Pump Up	Five	Pump 1 Pump 2 Pump 3 Pump 4 Pump 5	60% 50% 40% 30% 25%	80% 80% 80% 80% 80%
Pump Up	Six	Pump 1 Pump 2 Pump 3 Pump 4 Pump 5 Pump 6	60% 50% 40% 30% 25% 20%	80% 80% 80% 80% 80% 80%

Relay Function	Relay I.D.	On Setpoint	Off Setpoint
Alarm	HiHi	90%	85%
Alarm	High	85%	80%
Alarm	Low	10%	15%
Alarm	LoLo	5%	10%

Example 1 Level Control

A vessel, containing liquid that has a variation in level that is to be monitored, with a high-level alarm set on Relay 1 and low level alarm set on Relay 2.

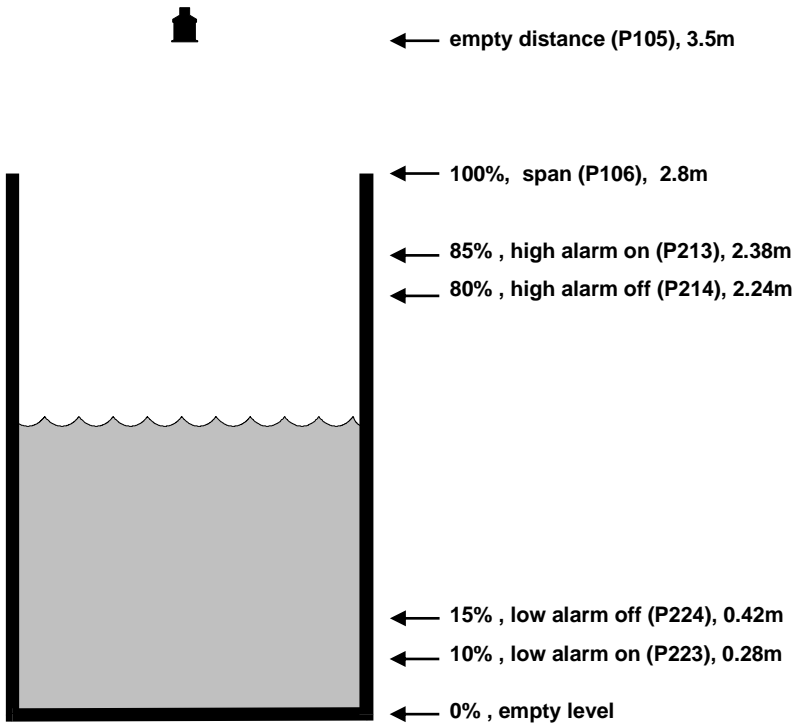

In this example, when the level rises to 2.38 m, relay 1 will come on until the level drops to 2.24 m when it will turn off. If the level drops to 0.28 m, then relay 2 will come on until it rises 0.42 m when it will turn off.

The display will show the level in the tank.

The mA output will be representative of level where 4mA = empty level (0%) and 20mA = 2.8m (100%)

To program the Quantum³ for **Example 1 Level Monitoring with Alarms** by using the **Quick Setup** menu proceed as follows.

If required access the **Program Mode**

Key in the **passcode** 1997 and press **ENTER**

At the **Quick Setup** menu press **ENTER** and as prompted, by the questions, select the relevant option and **ENTER**.

Question	Option
Level/Pump/Custom	1= Level App.
No. of Alarms	2= 2 Alarms
Type Alarm 1	1= High
Alarm No 1	1 = Set Relay 1
Type Alarm 2	2= Low
Alarm No 2	2 = Set Relay 2
Xducer (P101)	2= dB6
Material (P102)	1 = Liquid
Measnt Units (P104)	1 = metres
Empty Level (P105)	3.5 (metres)
Span (P106)	2.8 (metres)

Programming is now complete and the unit can be returned to the run mode, press **CANCEL** until **Run Mode?** Is displayed on the LCD press **ENTER**, and the Quantum³ will return to the **Run Mode**.

Note

If relay setpoints do not meet the exact requirements of the application, they can be modified to suit by pressing **ENTER** when, "For More Options Hit Enter", is displayed, and entering new values to relay setpoints as required. Alternatively, the relevant relay setpoint can be accessed either by the main menu system or directly via parameter number and changed as necessary.

Example 2 Sump Control (pump down)

A sump is typically used to temporarily hold water or effluent, and when the level reaches a specific point, the sump is pumped down, with the fluid being transferred to another process.

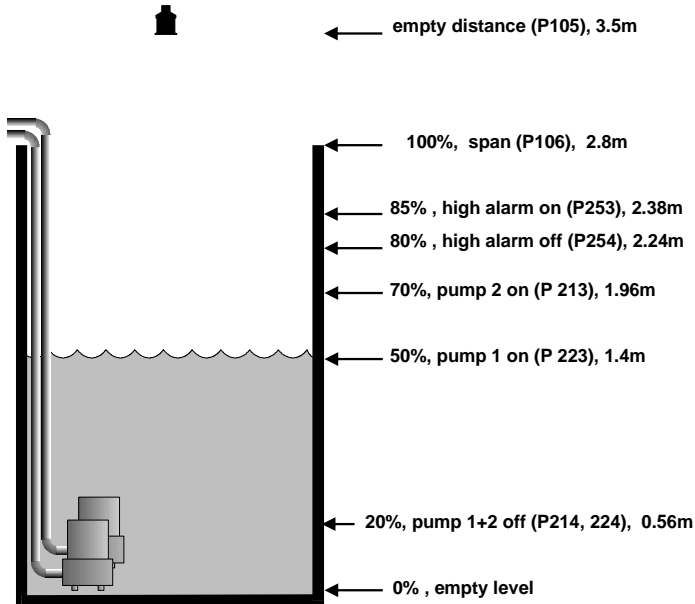

In this example, there are two pumps, which will be set to **alternate duty assist**, so they come on alternately. **Pump 1** is to be set to **Relay 1**, **Pump 2** to **Relay 2**, and the **high-level alarm** to **Relay 5**.

This will operate as follows. During normal operation, **pump 1** will come on at 1.4 m, and pump down to 0.56 m. The setpoints are then shifted to **pump 2**, which will come on first next time.

During peak periods, when **pump 1** cannot cope, **pump 1** will come on at 1.4 m, **pump 2** will come on at 1.96 m, and pump down to 0.56 m. The setpoints are then shifted to **pump 2**, which will come on **first next time**.

If neither pump can cope, and the level rises to 2.38 m, then the **alarm** relay (relay 5) will come on, and go off when the level falls to 2.24 m. This will indicate insufficient capacity of the pumps.

The display will show the level in the sump and the mA output will be representative of level where 4mA = empty level (0%) and 20mA = 2.9m (100%).

To program the Quantum³ for **Example 2 Sump control (pump down)** by using the **Quick Setup** menu proceed as follows.

If required access the **Program Mode**

Key in the **passcode** 1997 and press **ENTER**

At the **Quick Setup** menu press **ENTER** and as prompted, by the questions, select the relevant option and **ENTER**.

Question	Option
Level/Pump/Custom	2=Pump Down
No. of Pumps	2=2 Pumps
Pump Duty	3=Alt DutAss
Pump No 1	1 = Set Relay 1
Pump No 2	2 = Set Relay 2
No. of Alarms	1=1 Alarms
Type Alarm 1	1=High Alarm
Alarm No 1	5 = Set Relay 5
Xducer (P101)	2=dB6
Measnt Units (P104)	1 = metres
Empty Level (P105)	3.5 (metres)
Span (P106)	2.8 (metres)

Programming is now complete and the unit can be returned to the run mode, press **CANCEL** until **Run Mode?** Is displayed on the LCD press **ENTER**, and the Quantum³ will return to the **Run Mode**.

Note

If relay setpoints do not meet the exact requirements of the application, they can be modified to suit by pressing ENTER when, "For More Options Hit Enter", is displayed, and entering new values to relay setpoints as required. Alternatively, the relevant relay setpoint can be accessed either by the main menu system or directly via parameter number and changed as necessary.

This page left blank intentionally

Chapter 5 Parameter Guide

This chapter outlines all parameters available in the Quantum³, as they appear in the menu system.

Menu System Diagrams

Shown below is a set of charts to show you how all the various parts can be found using the menu system.

Top Level Menu

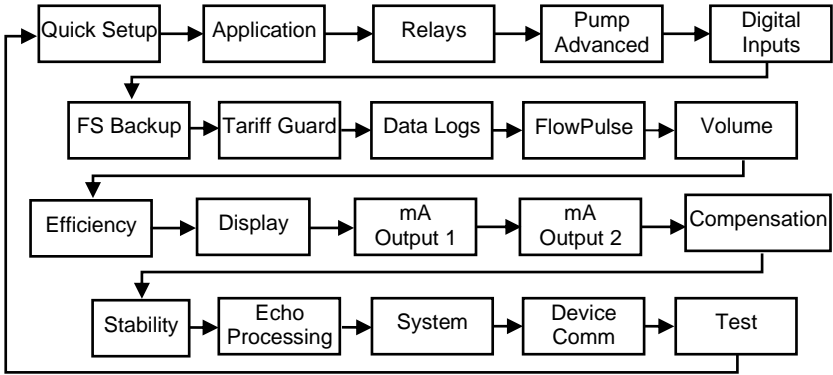

Application Menu

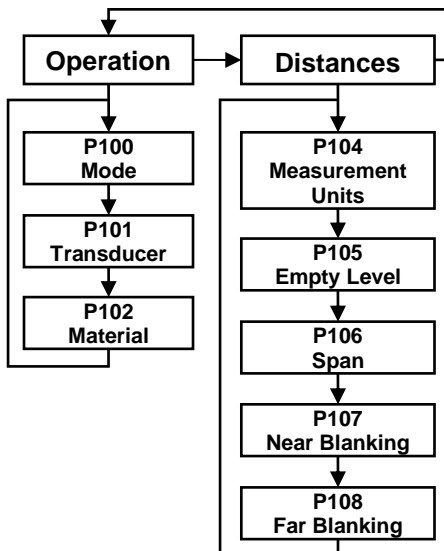

Relays Menu

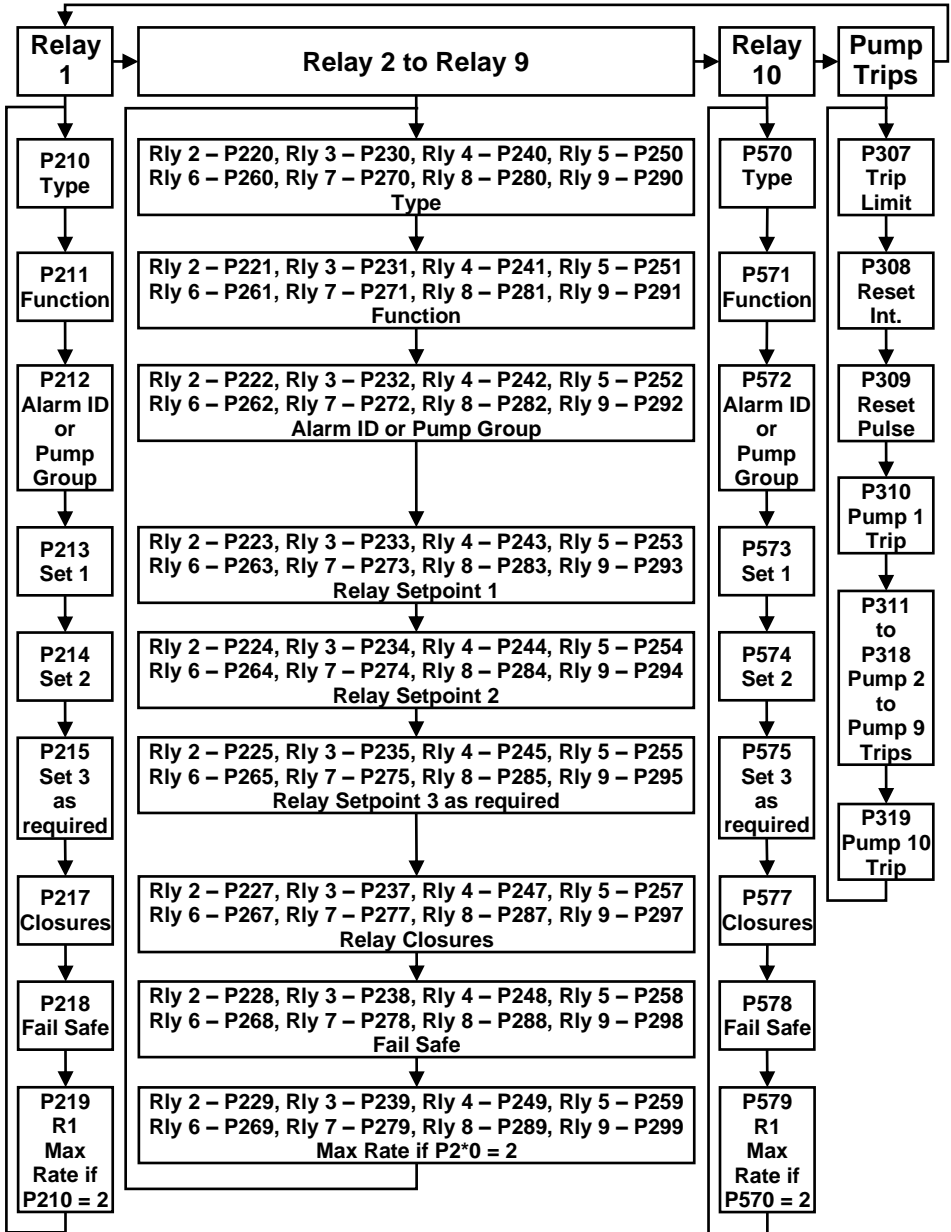

Pump “Advanced” Menu

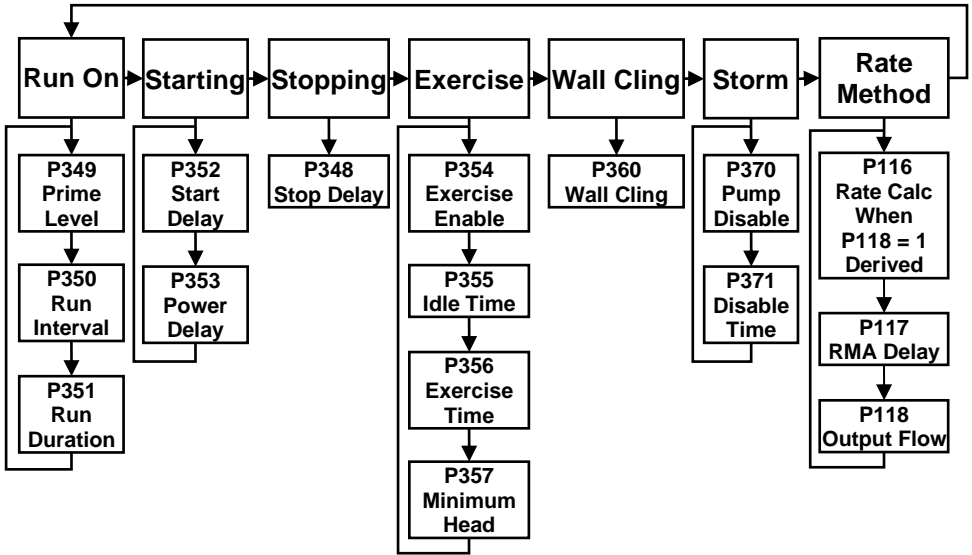

Digital Inputs Menu

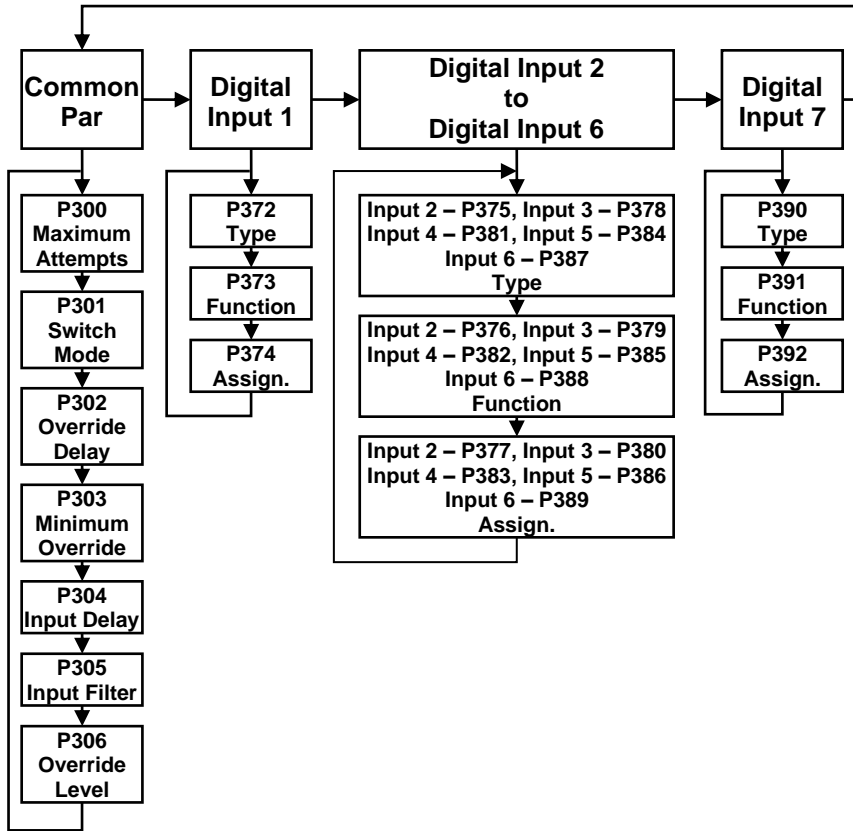

Float Switch Backup

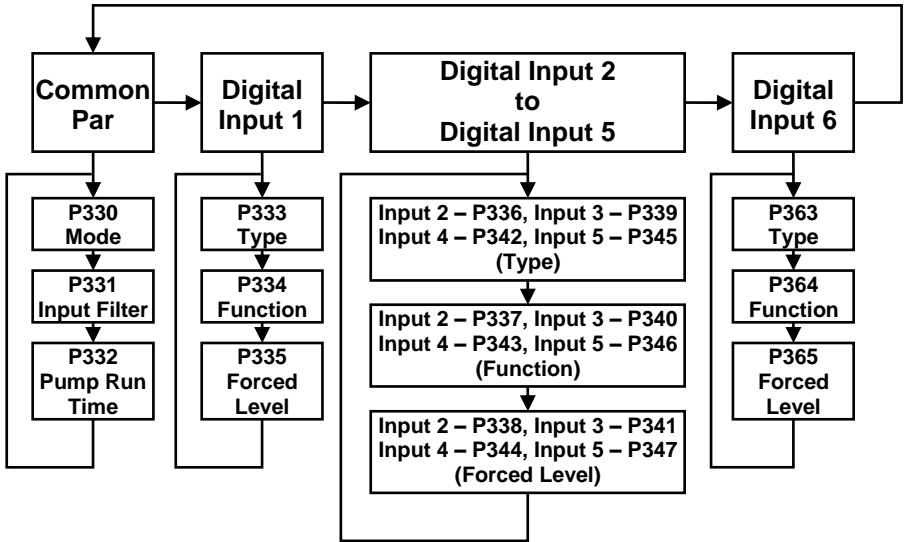

Tariff Guard Menu

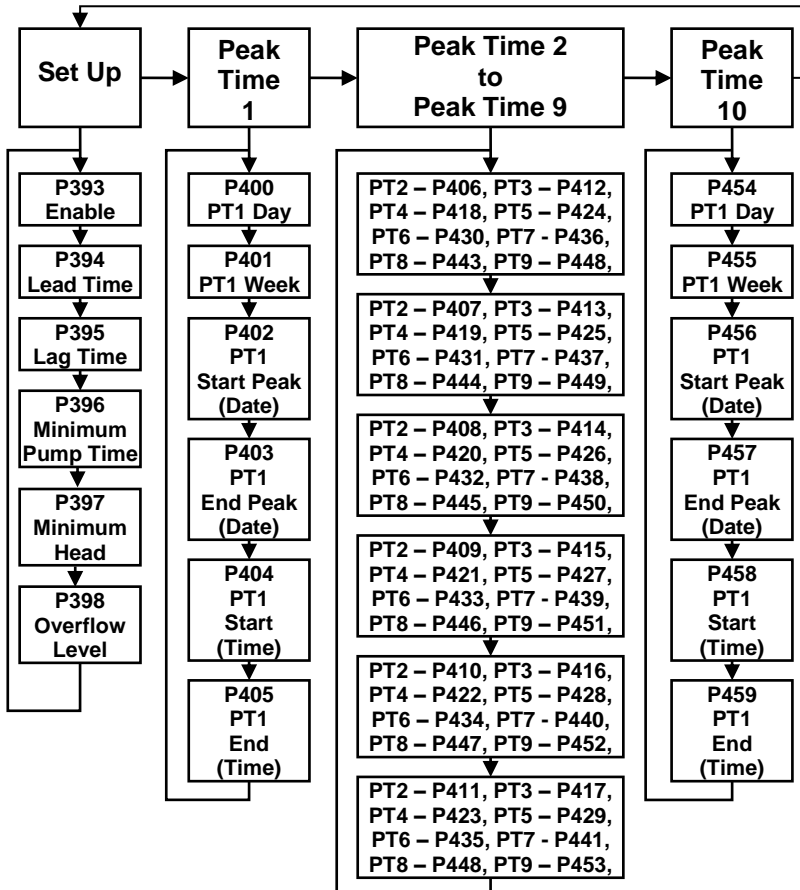

Data Logs Menu

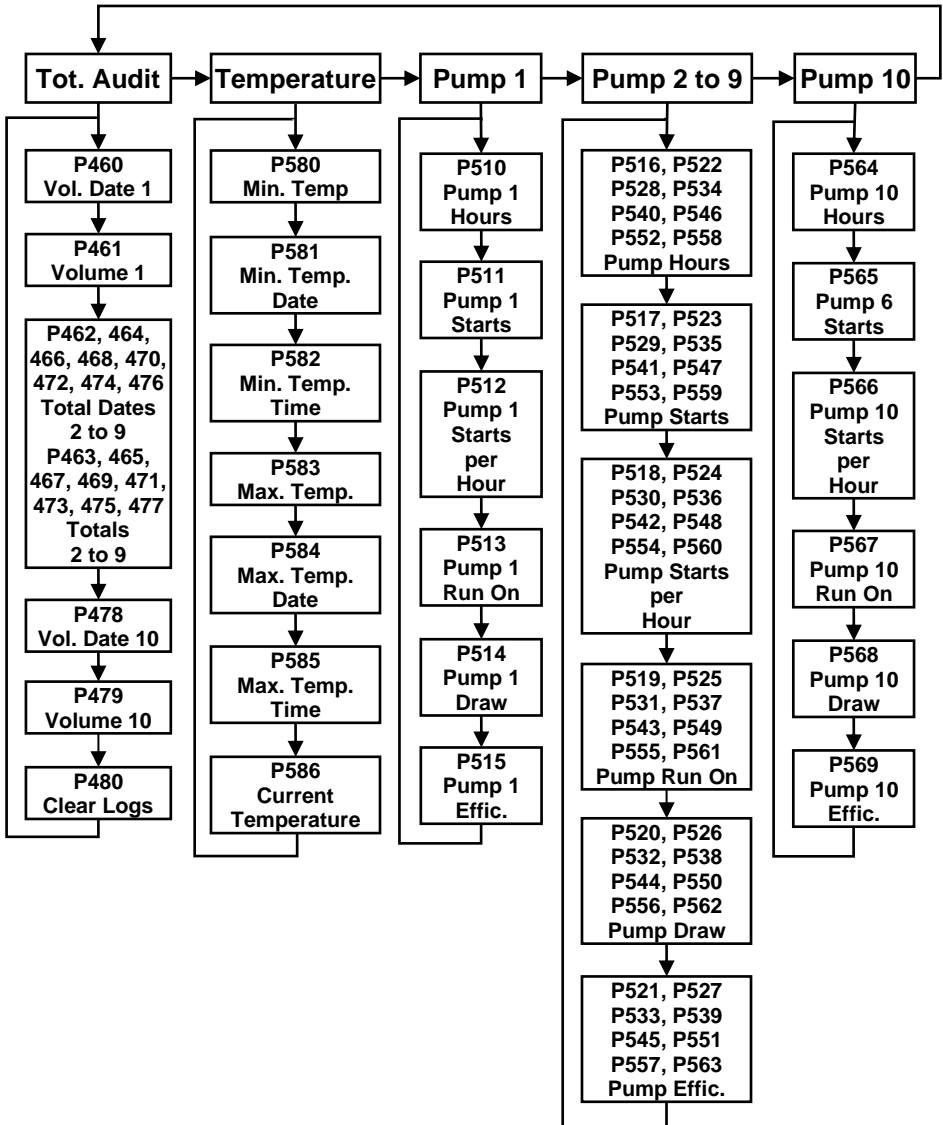

FlowPulse

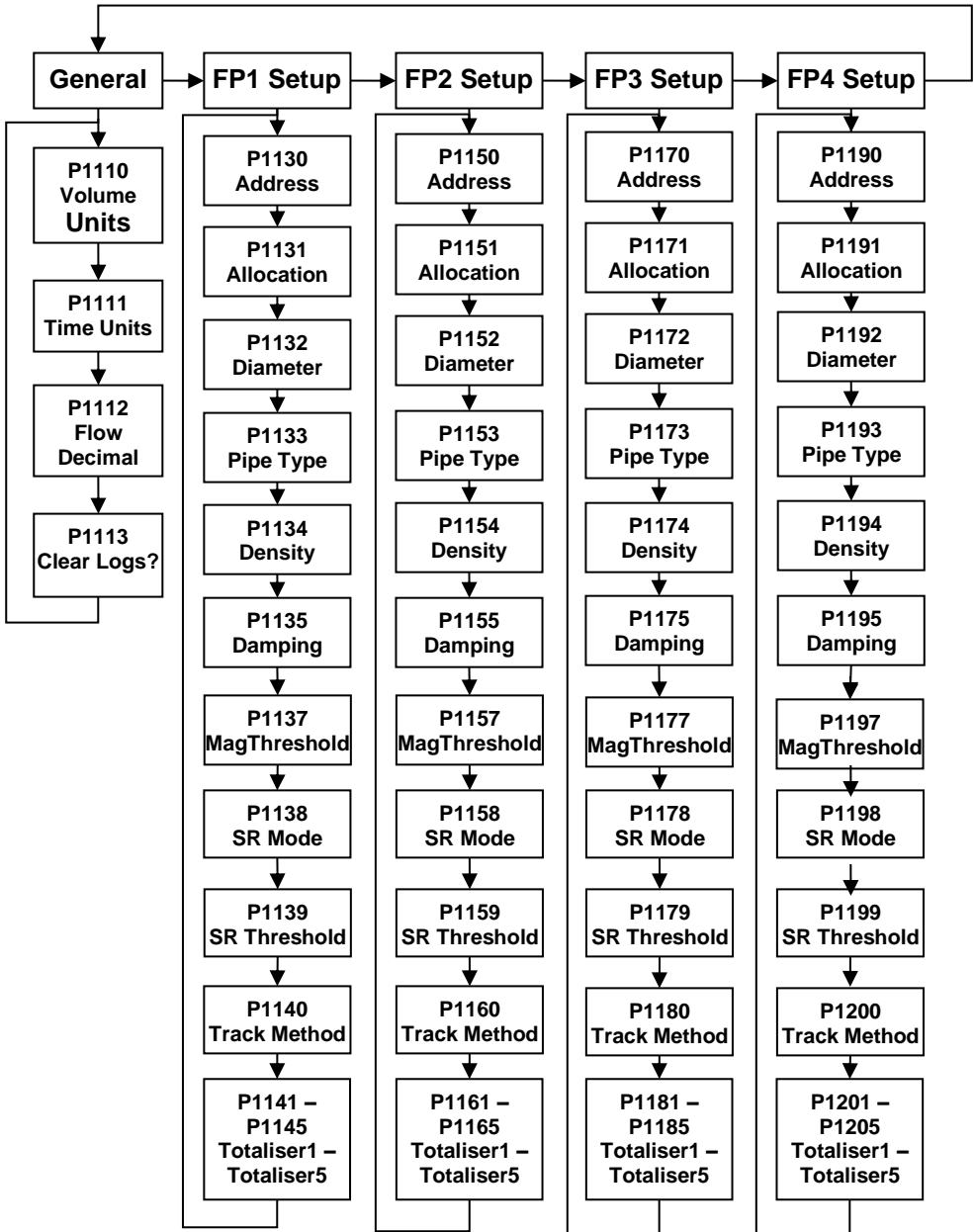

Pumped Volume Menu

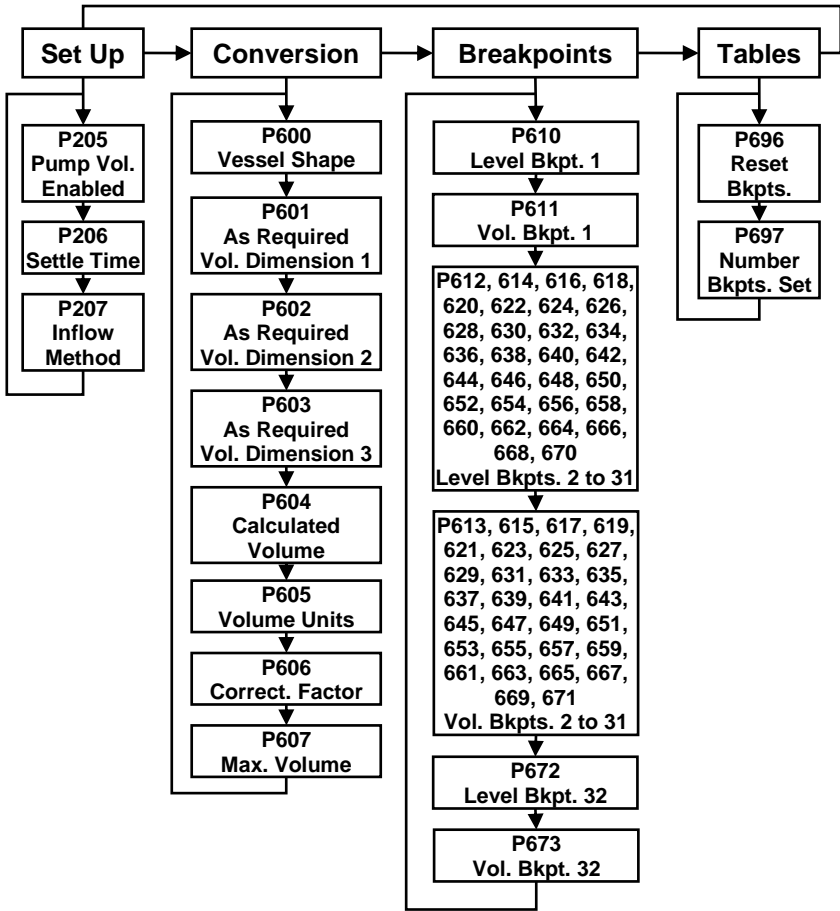

Efficiency Menu

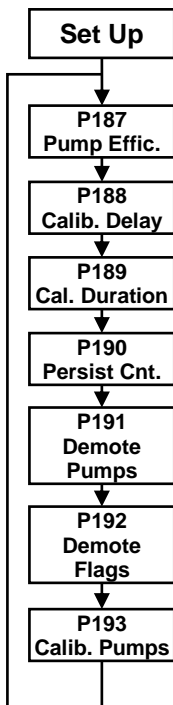

Display Menu

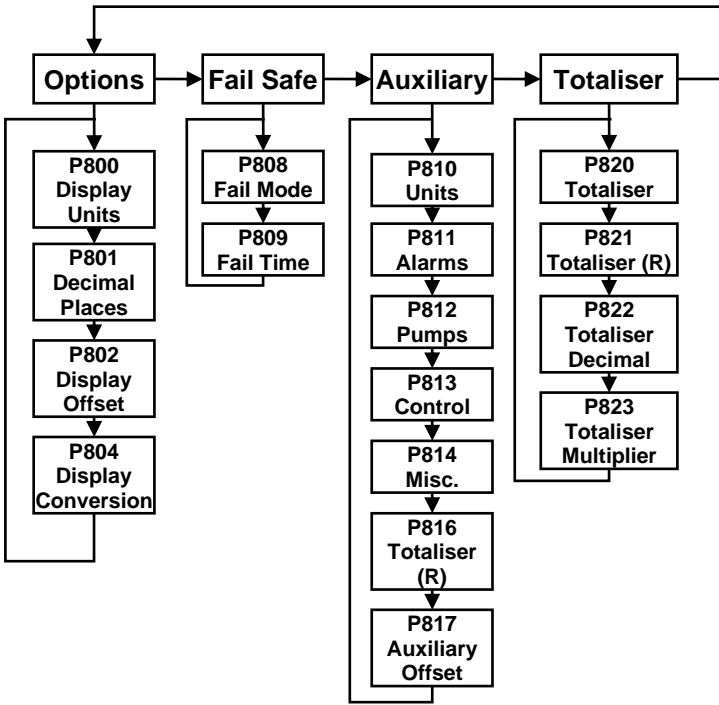

mA Output 1 Menu

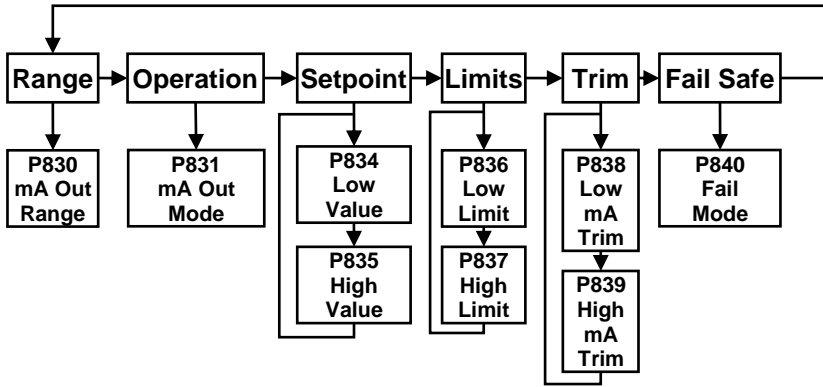

mA Output 2 Menu

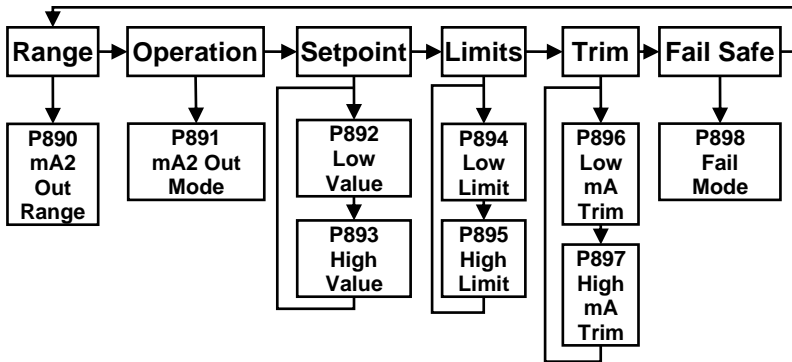

Compensation Menu

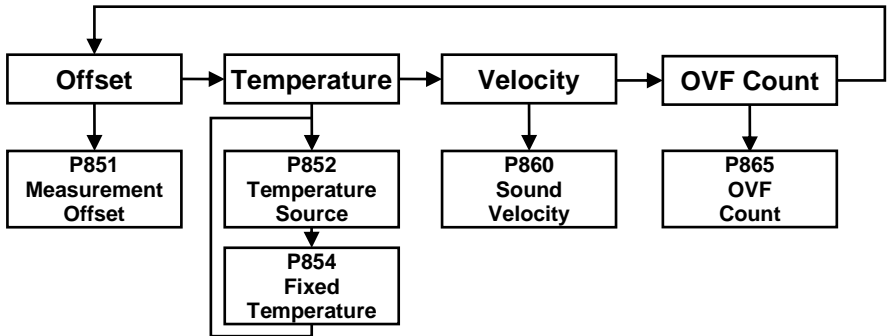

Stability Menu

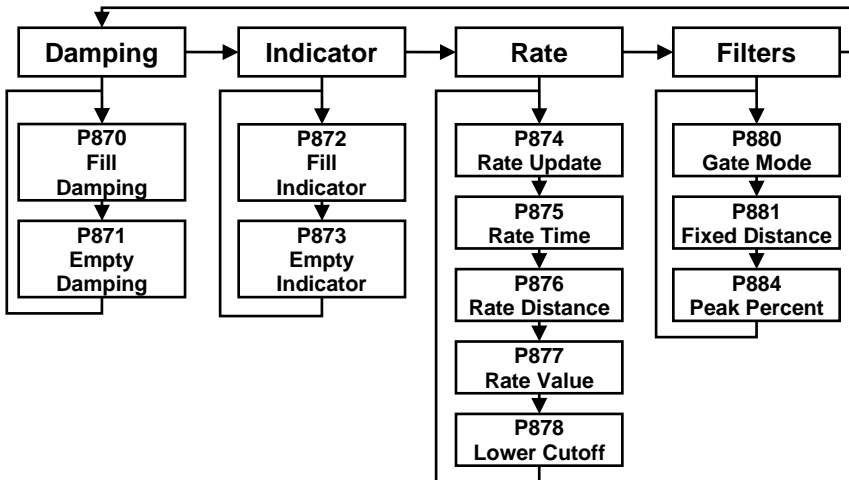

Echo Processing Menu

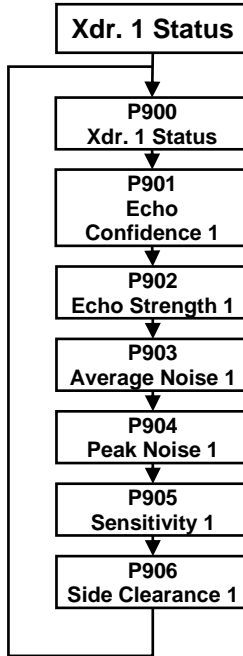

System Menu

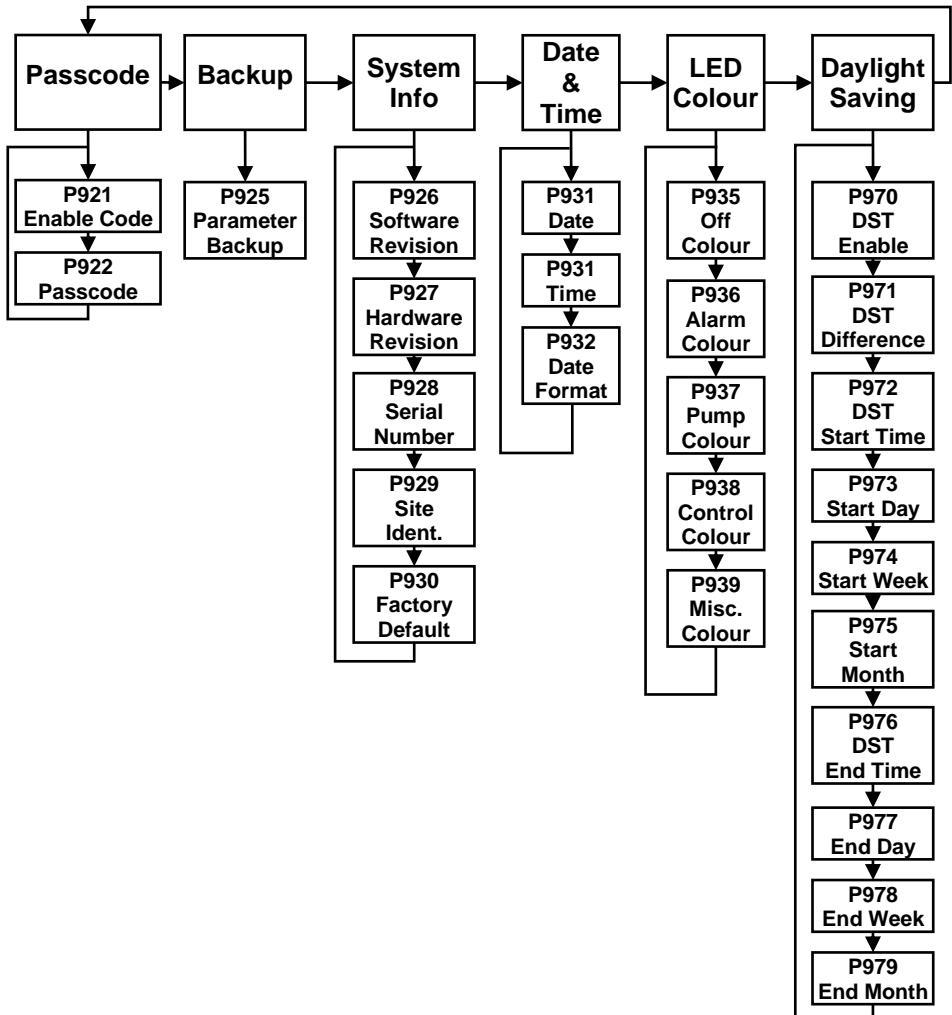

Device Comm Menu

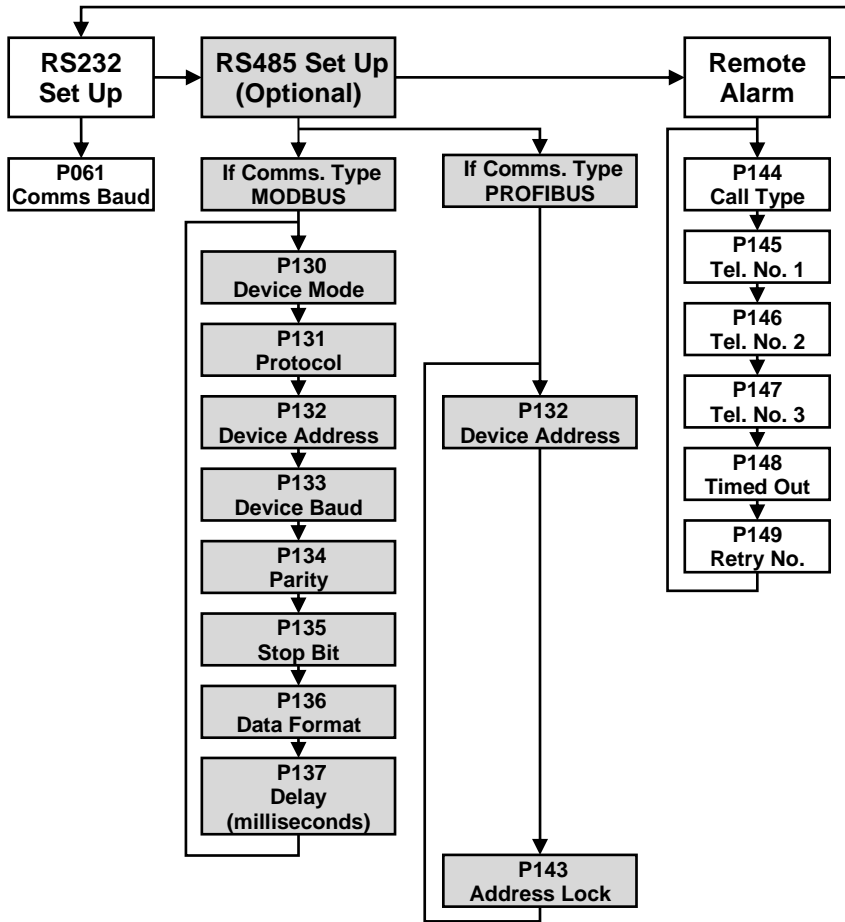

Test Menu

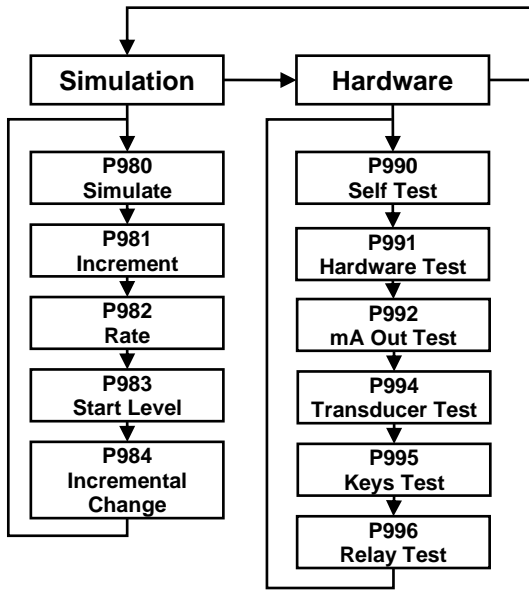

Chapter 6 Parameter Listing and Description

This section describes all of the parameters. Any parameter can be reset to its default, by pressing the **n** hot key, whilst in program mode.

Application Parameters

Operation

P100 Mode of Operation

This parameter sets the mode of operation, when in run mode, and can be set to one of the following:

Option	Description
1= Distance (Default)	Display shows the distance from the transducer face to the surface.
2= Level	Display shows how full the vessel is.
3= Space	Display shows how empty a vessel is.

P101 Xducer (Transducer)

This parameter should be set to the transducer being used with the unit, and can be set to one of the following:

Option	Description
0=Auxiliary	Use the mA input device.
1 = dB3	Transducer is a dB3. Range 0.125 to 3.00 metres
2 = dB6 (Default)	Transducer is a dB6. Range 0.3 to 6.00 metres
3= dB10	Transducer is a dB10. Range 0.3 to 10.00 metres
4= dB15	Transducer is a dB15. Range 0.5 to 15.00 metres
5= dB25	Transducer is a dB25. Range 0.6 to 25.00 metres
6 = dB40	Transducer is a dB40. Range 1.2 to 40.00 metres
7 = dBS6	Transducer is a dBS6. Range 0.2 to 6.00 metres
8 = dBMach3	Transducer is a dBMach3 Range 0.0 to 2.425 mtrs.
10 = dB50	Transducer is a dB50. Range 2.0 to 50.00 metres
*11 = dBR16	Transducer is a mmWave radar. Range 0.077 to 16 metres
*12 = dBR8	Transducer is a mmWave radar. Range 0.077 to 8 metres

Important Information

* Please consult your local Pulsar distributor for the versions of firmware that the mmWAVE Radars are available in.

P102 Material

This parameter should be set to the type of material being monitored.

Option	Description
1 = Liquid (Default)	Use for liquids and flat solid materials
2 = Solid	Solid material that is heaped or at an angle
3 = Closed Tank	Used where material is contained in a closed tank.

Dimensions

P104 Measurement Units

This parameter sets the units you want to use for programming and display

Option	Description
1 = metres (Default)	All units of measure are METRES
2 = cm	All units of measure are CENTIMETRES
3 = mm	All units of measure are MILLIMETRES
4 = feet	All units of measure are FEET
5 = inches	All units of measure are INCHES

P105 Empty Level

This parameter is to be set to the **maximum distance** from the **face** of the transducer to the **empty point**, in **P104 Measurement Units**. Note this value affects span as well, (see important information below), so should be set before span.

Important Information

When using the **dB Mach 3** the **empty distance** is measured from the end of the **horn** to the **empty point** in **P104 Measurement Units**.

Important Information

When changing the Empty Distance (P105) you can also recalculate the values for the Span so that it equals the empty distance (P105) minus Near Blanking (P107) and the Relay Setpoints, so that they remain at the same percentage values of the empty distance as they were before you changed the empty distance (P105). You will be asked the question “Recalculate Span?” if you choose yes (enter 1), then the span will be recalculated. Any other answer will leave the span at its original value. You will then be asked if you want to “Recalculate Setpoints?”, if you choose yes (enter 1), then all Relay Setpoints will be recalculated as a percentage of the new empty distance. Any other answer will leave the setpoints at their original values.

P106 Span

This parameter should be set to the maximum distance from the **Empty Level (P105)** to the maximum material level. It is automatically set to be equal to the **Empty Level (P105)** less the **Near Blanking distance (P107)**, when you set the empty level.

P107 Near Blanking Distance

This parameter sets the distance from the face of the transducer that is not measurable and is pre-set to the minimum value dependant on the Xducer (P101) selected. It should not be set to less than this figure, but can be increased, typically to ignore close in obstructions.

Transducer	Near Blanking Distance
P101 = dB Mach3 Transducer	Default Blanking Distance = 0.000m
P101 = dB3 Transducer	Default Blanking Distance = 0.125m
P101 = dB6 Transducer	Default Blanking Distance = 0.300m
P101 = dB10 Transducer	Default Blanking Distance = 0.300m
P101 = dB15 Transducer	Default Blanking Distance = 0.500m
P101 = dB25 Transducer	Default Blanking Distance = 0.600m
P101 = dB40 Transducer	Default Blanking Distance = 1.200m
P101 = dB S6 Transducer	Default Blanking Distance = 0.200m
P101 = dB50 Transducer	Default Blanking Distance = 2.000m
P101 = dB R16 Radar	Default Blanking Distance = *0.077m
P101 = dB R8 Radar	Default Blanking Distance = *0.077m

*The signal emanates from the curved face of the Radar, but for the purposes of measurement it is taken from the drip shield.

P108 Far Blanking Distance

This is the distance (as a **percentage** of **empty level P105**) beyond the empty point that the unit will be able to measure, and by **default** is pre-set to **20%** of the empty level.

If the surface being monitored can extend beyond the **Empty Level (P105)** then the far blanking distance can be increased to a maximum of 100% of empty level.

This parameter is always entered as a % of empty level.

Relay Parameters

All relay related parameters are prefixed with a **2****.

The second digit of the three-figure parameter number denotes the relay number as follows:

21* parameters for Relay 1	22* parameters for Relay 2
23* parameters for Relay 3	24* parameters for Relay 4
25* parameters for Relay 5	26* parameters for Relay 6
27* parameters for Relay 7	28* parameters for Relay 8
29* parameters for Relay 9	57* parameters for Relay 10

The third digit is parameter specific and is the same for each relay resulting in the following parameter numbers for each relay.

Relay 1 21**0** to 21**9**

Relay 2 22**0** to 22**9**

Relay 3 23**0** to 23**9**

Relay 4 24**0** to 24**9**

Relay 5 25**0** to 25**9**

Relay 6 26**0** to 26**9**

Relay 7 27**0** to 27**9**

Relay 8 28**0** to 28**9**

Relay 9 29**0** to 29**9**

Relay 10 57**0** to 57**9**

Relay Type

This parameter defines what type each relay should be, see the table below for available options.

Option	Description
0= Not In Use (Default)	Relay not programmed, and LED will always be off.
1= Alarm	Relay is programmed as an alarm relay, which will de-energise to switch the alarm ON , and energise to switch the alarm OFF . This will ensure an alarm is raised if the power fails to the unit.
2= Pump	Relay is programmed as a pump relay, which will energise to switch the pump ON , and de-energise to switch the pump OFF .
3= Control	Relay is programmed as a control relay, which will energise to switch ON , and de-energise to switch OFF .
4= Miscellaneous	Relay is programmed as a miscellaneous relay, which will energise to switch ON , and de-energise to switch OFF .
5= Pump by time	Relay is programmed as a pump relay, which will energise at its ON level setpoint, and de-energise at its OFF level setpoint or after a predetermined time period, whichever occurs first .

Alarms

P210, 220, 230, 240, 250, 260, 270, 280, 290, 570 =1 (Alarm)

The **second parameter** for each relay will determine the **function** of the alarm.

P211, P221, P231, P241, P251, P261, P271, P281, P291, P571

Relay Function

This parameter defines what **function** the **alarm** will respond to as follows.

Option	Description
0= Off (Default)	Relay will not operate.
1= Level	Alarm is based on the level in the vessel, and the type of level alarm (P212, 222, 232, 242, 252, 262, 272, 282, 292, 572) and two setpoints must be set (P213, 223, 233, 243, 253, 263, 273, 283, 293, 573 & P214, 224, 234, 244, 254, 264, 274, 284, 294, 574). Setpoints are entered in Display Units or % of span as referenced to Empty Level *.
2= Rate of Change	Alarm is based on the rate of change of level in the vessel, and the type of rate of change alarm (P212, 222, 232, 242, 252, 262, 272, 282, 292, 572) and two setpoints must be set (P213, 223, 233, 243, 253, 263, 273, 283, 293, 573/P214, 224, 234, 243, 253, 263, 273, 283, 293, 573).Setpoints are entered in Display Units per minute or % of span per minute and a negative value should be entered for a Rate Alarm on a decreasing level, and a positive value for an increasing level.
3= Temperature	Alarm is based on the temperature, and the type of temperature alarm (P212, 222, 232, 242, 252, 262, 273, 283, 293, 573) and two setpoints must be set (P213, 223, 233, 243, 253, 263,273, 283, 293, 573 & P214, 224, 234, 244, 254, 264, 274, 284, 294, 574). The temperature used depends on the temperature source (P852). Setpoints are entered in °C.
4= Loss of Echo	Alarm is raised if the Failsafe Timer (P809) expires. No setpoints are required.
5= Loss of Clock	Alarm is raised if the real time clock fails. No setpoints are required.

Option	Description
6= Pump Efficiency	When Pump Efficiency is enabled, Alarm is based on the Efficiency of the pump which is allocated to the Relay I.D. (P212, 222, 232, 242, 252, 262, 272, 282, 292, 572) and two setpoints must be set (P213, 223, 233, 243, 253, 263, 273, 283, 293 & P214, 224, 234, 244, 254, 264, 274, 284, 294, 574). Setpoints are entered in %.
7 = Device Fail	Alarm is raised if a device, connected to the relay assigned in Alarm ID (P212, 222, 232, 242, 252, 262, 272, 282, 292, 572), fails. E.g. pump is put out of service. No setpoints are required.
8 = Device Alarm	Alarm is raised if a fail signal is detected on the digital input as assigned in Alarm ID (P212, 222, 232, 242, 252, 262, 272, 282, 292, 572) No setpoints are required.
9 = OVF Alarm	Alarm is raised to indicate a “ High ” level or a potential “ Overflow ” condition and four setpoints must be set, Overflow Level (P213, 223, 233, 243, 253, 263, 273, 283, 293, 573). Reset Level (P214, 224, 234, 254, 264, 274, 284, 294, 574). High Alarm Level (P215, 225, 235, 245, 255, 265, 275, 285, 295, 575). All level Setpoints are entered in Display Units or % of span as referenced to Empty Level *. Time to Overflow (P219, 229, 239, 249, 259, 269, 279, 289, 579). Setpoint entered in minutes.
10 = RMA Alarm	Alarm is based on the rate of change of level during a pumping cycle, and on the type of RMA alarm (P212, 222, 232, 242, 252, 262, 272, 282, 292, 572) and 3 setpoints must be set. Alarm Setpoint (P213, 223, 233, 243, 253, 263, 273, 283, 293, 573) in rate measurement units. Persistence Time (P214, 224, 234, 254, 264, 274, 284, 294, 574) in seconds. Prime Head Level (P215, 225, 235, 245, 255, 265, 275, 285, 295, 575) in level display units, alarm will not activate below this level.
13 = Loss of Comms	Alarm is raised if there is a comms failure. No setpoints are required.
15 = Tariff Alarm (Available from firmware version 7.5.1)	Alarm is raised when the unit enters Tariff Guard mode. Tariff Guard enable (P393) must be set to ‘1’ for this option to be selectable. No setpoints are required

- * To set figures in % press the  hot key to show and enter % figure relative to empty level.

Note that the loss of echo and loss of clock will also be shown on the display as “LOST ECHO” and “LOST CLOCK” respectively.

P212, P222, P232, P242, P252, P262, P272, P282, P292, P572

Relay Alarm ID

The **third parameter** for each **alarm** relay determines the **ID** for the relay you wish to set.

When P211, 221, 231, 241, 251, 261, 271, 281, 291, 571 = 1 (Level) or 2 (Rate of Change) or 3 (Temperature)

This parameter defines which **alarm type**, or **identification**, the relay should respond to, as follows.

Alarm ID	Description	Setpoints
1= General (Default)	Relay goes “ON” when the value rises to the ON setpoint and goes “OFF” when the value lowers to the OFF setpoint.	P213, 223, 233, 243, 253, 263, 273, 283, 293, 573 is ON Setpoint; P214, 224, 234, 244, 254, 264, 274, 284, 294, 574 is OFF Setpoint
2= High	Relay goes “ON” when the value rises to the ON setpoint and goes “OFF” when the value lowers to the OFF setpoint.	ON>OFF Relay Setpoints P213, 223, 233, 243, 253, 263, 273, 283, 293, 573 and P214, 224, 234, 244, 254, 264, 274, 284, 294, 574 Setpoints can be set in any order as the unit ‘knows’ that you are setting a high-level alarm.
3= Hi-Hi	Same as 2 = High, but different identifier.	

Alarm ID	Description	Setpoints
4= Low	Relay goes “ON” when the value lowers to the ON setpoint and goes “OFF” when the value rises to the OFF setpoint.	ON<OFF Relay Setpoints P213, 223, 233,243, 253, 263, 273, 283, 293, 573 and P214, 224, 234, 244, 254, 264, 274, 284, 294, 574 Setpoints can be set in any order as the unit ‘knows’ that you are setting a low level alarm.
5= LoLo	Same as 4=Lo, but different identifier.	
6= In bounds	Relay goes “ON” if value is inside the zone between the two setpoints.	Relay Setpoints, P213, 223, 233, 243, 253, 263, 273, 283, 293, 573 and P214, 224, 234, 244, 254, 264, 274, 284, 294, 574 Setpoints can be set in any order as the unit ‘knows’ that you are setting an in bounds alarm.
7= Out of bounds	Relay goes “ON” if value is outside the zone between the two setpoints.	Relay Setpoints, P213, 223, 233, 243, 253, 263, 273, 283, 293, 573 and P214, 224, 234, 244, 254, 264, 274, 284, 294, 574 Setpoints can be set in any order as the unit ‘knows’ that

When P211, 221, 231, 241, 251, 261, 271, 281, 291, 571 = 4 (Loss of Echo), 5 (Loss of Clock) or 9 = OVF Alarm

This parameter has no function and will not be displayed.

When P211, 221, 231, 241, 251, 261, 271, 281, 291, 571 = 6 (Pump Efficiency)

This parameter assigns the **alarm** to the appropriate **pump relay** as detailed below.

Option	Description
0=Off (Default)	Relay will not operate.
1 = Relay 1	Alarm is assigned to pump on Relay 1
2 = Relay 2	Alarm is assigned to pump on Relay 2
3 = Relay 3	Alarm is assigned to pump on Relay 3
4 = Relay 4	Alarm is assigned to pump on Relay 4
5 = Relay 5	Alarm is assigned to pump on Relay 5
6 = Relay 6	Alarm is assigned to pump on Relay 6
7 = Relay 7	Alarm is assigned to pump on Relay 7
8 = Relay 8	Alarm is assigned to pump on Relay 8
9 = Relay 9	Alarm is assigned to pump on Relay 9
10 = Relay 10	Alarm is assigned to pump on Relay 10
11 = All	Alarm is assigned to all relays designated as pump

When P211, 221, 231, 241, 251, 261, 271, 281, 291, 571 = 7 (Device Fail)

This parameter defines which **failed device relay**, the **alarm** should respond to, as follows.

Alarm ID	Description	Setpoints
1 = Fail Rel.1 (Default)	Relay goes “ ON ” when a device failure is detected on relay 1 .	None
2 = Fail Rel.2	Relay goes “ ON ” when a device failure is detected on relay 2 .	None
3 = Fail Rel.3	Relay goes “ ON ” when a device failure is detected on relay 3 .	None
4 = Fail Rel.4	Relay goes “ ON ” when a device failure is detected on relay 4 .	None
5 = Fail Rel.5	Relay goes “ ON ” when a device failure is detected on relay 5 .	None
6 = Fail Rel.6	Relay goes “ ON ” when a device failure is detected on relay 6 .	None
7 = Fail Rel.7	Relay goes “ ON ” when a device failure is detected on relay 7 .	None
8 = Fail Rel.8	Relay goes “ ON ” when a device failure is detected on relay 8 .	None
9 = Fail Rel.9	Relay goes “ ON ” when a device failure is detected on relay 9 .	None
10 = Fail Rel.10	Relay goes “ ON ” when a device failure is detected on relay 10 .	None
11 = Any 1 Fail	Relay goes “ ON ” when a device failure is detected on any 1 relay .	None
12 = Any 2 Fail	Relay goes “ ON ” when 2 device failures are detected on any 2 relays .	None

When P211, 221, 231, 241, 251, 261, 271, 281, 291, 571 = 8 (Device Alarm)

This parameter defines which **digital input**, the **alarm** should respond to, as follows.

Alarm ID	Description	Setpoints
1 = Fail Inp.1 (Default)	Relay goes “ ON ” when a fail signal is detected on digital input 1 .	None
2 = Fail Inp.2	Relay goes “ ON ” when a fail signal is detected on digital input 2 .	None
3 = Fail Inp.3	Relay goes “ ON ” when a fail signal is detected on digital input 3 .	None
4 = Fail Inp.4	Relay goes “ ON ” when a fail signal is detected on digital input 4 .	None
5 = Fail Inp.5	Relay goes “ ON ” when a fail signal is detected on digital input 5 .	None
6 = Fail Inp.6	Relay goes “ ON ” when a fail signal is detected on digital input 6 .	None
7 = Fail Inp.7	Relay goes “ ON ” when a fail signal is detected on digital input 7 .	None

When P211, 221, 231, 241, 251, 261, 271, 281, 291, 571 = 10 (RMA Alarm)

This parameter defines which **alarm type**, or **identification**, the relay should respond to, as follows.

Alarm ID	Description	Setpoints
1 = Blockage (Default)	Relay goes “ON” when the pumping rate is lower than the Alarm setpoint for longer than the Persistence Time provided the level is above the Prime Head and goes “OFF” when the pumping rate rises above the Alarm setpoint for longer than the Persistence Time .	P213, 223, 233, 243, 253, 263, 273, 283, 293, 573 is Alarm Setpoint; P214, 224, 234, 244, 254, 264, 274, 284, 294, 574 is Persistence Time ; P215, 225, 235, 245, 255, 265, 275, 285, 295, 575 is Prime Head .
2 = Burst	Relay goes “ON” when the pumping rate is above than the Alarm setpoint for longer than the Persistence Time provided the level is above the Prime Head and goes “OFF” when the pumping rate lowers below the Alarm setpoint for longer than the Persistence Time .	P213, 223, 233, 243, 253, 263, 273, 283, 293, 573 is Alarm Setpoint; P214, 224, 234, 244, 254, 264, 274, 284, 294, 574 is Persistence Time ; P215, 225, 235, 245, 255, 265, 275, 285, 295, 575 is Prime Head .
3 = NRV	Relay goes “ON” when a pumping rate above the Alarm setpoint is seen on a FlowPulse that is allocated to either “Pump n” or “All” for longer than the Persistence Time provided the level is above the Prime Head and goes “OFF” when the pumping rate lowers below the Alarm setpoint for longer than the Persistence Time .	P213, 223, 233, 243, 253, 263, 273, 283, 293, 573 is Alarm Setpoint; P214, 224, 234, 244, 254, 264, 274, 284, 294, 574 is Persistence Time ; P215, 225, 235, 245, 255, 265, 275, 285, 295, 575 is Prime Head .

4 = Storm	Relay goes “ON” when the pumping rate is above than the Alarm setpoint for longer than the Persistence Time provided the level is above the Prime Head and goes “OFF” when the pumping rate lowers below the Alarm setpoint for longer than the Persistence Time .	P213, 223, 233, 243, 253, 263, 273, 283, 293, 573 is Alarm Setpoint; P214, 224, 234, 244, 254, 264, 274, 284, 294, 574 is Persistence Time ; P215, 225, 235, 245, 255, 265, 275, 285, 295, 575 is Prime Head .
-----------	-------------------------------------------------------------------------------------------------------------------------------------------------------------------------------------------------------------------------------------------------------------------------------------------------------	-------------------------------------------------------------------------------------------------------------------------------------------------------------------------------------------------------------------------------------

The **fourth parameter** and the **fifth parameter** for each relay set the **Alarm “ON”** and **“OFF”** points. For a *high alarm*, the **“ON”** is set **higher than “OFF”**. For *low alarm*, then **“ON”** is set **lower than “OFF”**. See the appropriate **alarm ID**, table (P212, 222, 232, 242, 252, 262, 272, 282 292 572) for further information.

When P211, 221, 231, 241, 251, 261, 271, 281, 291, 571 = 1 (Level), 2 (Rate of Change), 3 (Temp.) or 6 (Efficiency)

P213, P223, P233, P243, P253, P263, P273, P283, P293, P73

Relay Setpoint 1

Determines the **“ON”** or **“OFF”** point for the alarm according to the **ID** selected.

P214, P224, P234, P244, P254, P264, P274, P284, P294, P574

Relay Setpoint 2

Determines the **“ON”** or **“OFF”** point for the alarm according to the **ID** selected.

Important Information

Setpoints are entered in values according to the **function** selected.

Level - entered in Display Units or % of span as referenced to Empty Level.

Rate of Change - entered in Display Units per minute or % of span per minute. For an alarm on an increasing level enter setpoints as a positive value, for an alarm on a decreasing level enter setpoints as a negative value.

Temperature - entered in °C.

Efficiency – entered in % value of efficiency.

See the appropriate **alarm function**, table (P211, 221, 231, 241, 251, 261, 271, 281, 291, 571) for further information.

- * To set figures in % press the  hot key to show and enter % figure relative to empty level.

When P211, 221, 231, 241, 251, 261, 271, 281, 291, 571 = 4 (Loss of Echo), 5 (Loss of Clock), 7 (Device Fail) or 8 (Device Alarm)
These parameters have no function and will not be displayed.

When P211, 221, 231, 241, 251, 261, 271, 281, 291, 571 = 9 (OVF Alarm)

P213, P223, P233, P243, P253, P263, P273, P283, P294, P573

Relay Setpoint 1

This parameter determines the “**Overflow Level**”, this is the level at which an overflow would occur and is the level that the unit will calculate the time to overflow to.

P214, P224, P234, P244, P254, P264, P274, P284, P294, P574

Relay Setpoint 2

This parameter determines the “**Reset Level**”, this level determines the point the level has to be below (of fall below) before an activated alarm can be considered to be deactivated, provided the time to overflow does not exceed the “**Time to Overflow**” (P219, 229, 238, 249, 259, 269, 279, 289, 299, 579) and the level is below the “**Reset Level**”, the alarm will turn “**OFF**”.

P215, P225, P235, P245, P255, P265, P275, P285, P295, P575

Relay Setpoint 3

This parameter determines the level at which the “**High Alarm**” will be activated and should be set below or at the same level as the “**Overflow Level**” (P213, 223, 233, 243, 253, 263, 273, 283, 293, 573).

Relay setpoints 1, 2 and 3 are entered in values of Measurement Units (P104)

P219, P229, P239, P249, P259, P269, P279, P289, P299, P579

OVF Time

This parameter determines the time, prior to a potential overflow occurrence, at which the alarm will activate if it is calculated that an overspill is likely to occur.

When P211, 221, 231, 241, 251, 261, 271, 281, 291, 571 =10 (RMA Alarm)

P213, P223, P233, P243, P253, P263, P273, P283, P294, P573

Relay Alarm Setpoint

This parameter determines the RMA alarm **ON/OFF** point, this is the **rate of change during pumping** at which a potential **burst** or **blockage** condition may occur (depending on Relay Alarm ID). Units are in rate measurement units and are dependent on **P116 Rate Method**.

P214, P224, P234, P244, P254, P264, P274, P284, P294, P574

Relay Setpoint 2

This parameter determines the “**Persistence Time**”. This is the amount of time the rate has to **persist** above/below the **Alarm Setpoint** (P213, 223, 233, 243, 253, 263, 273, 283, 293, 573) before the alarm will change state. It is used to prevent relay “chatter” if the rate is near the alarm setpoint. Units are in **Seconds**.

P215, P225, P235, P245, P255, P265, P275, P285, P295, P575

Relay Setpoint 3

This parameter determines the “**Prime Head Level**”. The RMA function will not **raise** an alarm below this level but will allow an alarm to turn off. Units are in Measurement Units (P104).

Pumps

When P210, 220, 230, 240, 250, 260, 270, 280, 290, 570 =2 (Pump)

When a relay is used for a **pump** function, then the **second parameter** determines the **pump duty** that will be used to control the operating cycle of the pump(s).

P211, P221, P231, P241, P251, P261, P271, P281, P291, P571

Relay Function,

This parameter defines which **pump duty** the relay should respond to as follows.

Pump Duty	Description
0= Off (Default)	Relay is always de-energised.
1= Fixed duty assist	All pumps are used to assist each other (run at the same time) and each pump has its own setpoints. (P213, 223, 233, 243, 253, 263, 273, 283, 293, 573 & P214, 224, 234, 244, 254, 264, 274, 284, 294, 574).
2= Fixed duty backup	If a pump fails to meet the demand (due to malfunction, intake blockage etc.), then it is stopped and another pump shall take over. Each pump has its own setpoints. (P213, 223, 233, 243, 253, 263, 273, 283, 293, 573 & P214, 224, 234, 244, 254, 264, 274, 284, 294, 574).
3= Alternate duty assist	All pumps are used to assist each other (run at the same time) and each pump has its own setpoints, (P213, 223, 233, 243, 253, 263, 273, 283, 293, 573 & P214, 224, 234, 244, 254, 264, 274, 284, 294, 574). but each time all pumps have stopped, then the setpoints are sequentially rotated between the pumps to ensure equal pump use.

Pump Duty	Description
4= Alternate duty backup	If a pump fails to meet the demand (due to malfunction, intake blockage etc.), then it is stopped and another pump shall take over. Each pump has its own setpoints, (P213, 223, 233, 243, 253, 263, 273, 283, 293, 573 & P214, 224, 234, 244, 254, 264, 274, 284, 294, 574). but each time all pumps have stopped, then the setpoints are sequentially rotated between the pumps to ensure equal pump use.
5= Duty backup and assist	First pump comes on, if it cannot cope, it goes off and next pump comes on (duty backup). This continues until the last pump comes on and if it cannot cope the first pump comes back on to assist the last pump (duty assist) if the level continues to rise all other pumps will come on (assist) in turn until the level decreases to the pump off points. Each pump has its own setpoints, (P213, 223, 233, 243, 253, 263, 273, 283, 293, 573 & P214, 224, 234, 244, 254, 264, 274, 284, 294, 574).

Pump Duty	Description
6= Service ratio duty assist	<p>All pumps are used to assist each other (run at the same time) and each pump has its own setpoints (P213, 223, 233, 243, 253, 263, 273, 283, 293, 573 & P214, 224, 234, 244, 254, 264, 274, 284, 294, 574). And a service ratio setting. The third setpoint (P215, 225, 235, 245, 255, 265, 275, 285, 295, 575) is used to set the service ratio. Each time a pump is required to start then the pump with the least running hours (with respect to the service ratio) is started (i.e. the setpoints are re-assigned accordingly).</p> <p>For example, if two pumps A and B have the service ratio set to 2 and 1 respectively, then pump A will operate for twice as many hours as pump B.</p>
7= Service ratio duty backup	<p>If a pump fails to meet the demand (due to malfunction, intake blockage and so on), then it is stopped and another pump shall take over. Each time a pump is required to start then the pump with the least running hours (with respect to the service ratio) is started (i.e. the setpoints are re-assigned accordingly). Each pump has its own setpoints (P213, 223, 233, 243, 253, 263, 273, 283, 293, 573 & P214, 224, 234, 244, 254, 264, 274, 284, 294, 574). The third setpoint (P215, 225, 235, 245, 255, 265, 275, 285, 295, 575) is used to set the service ratio. For example, if two pumps A and B have the service ratio set to 2 and 1 respectively, then pump A will operate for twice as many hours as pump B.</p>

Pump Duty	Description
8= First On First Off , alternate duty assist	The first pump switched on is the first pump to be switched off, etc. regardless of the set points, so the setpoints are dynamically changed to enable this.
9 = Service Ratio Standby	When a service ratio duty is being used, on all other pumps in use, the standby pump can be started on a ratio basis only, when it will assume the setpoints of the next pump to start. The third setpoint (P215, 225, 235, 245,255, 265, 275, 285, 295, 575) is used to set the service ratio.
10 = Two Pump Sets	There are four pumps. Two rotate their start-up sequence with each other. If the two pumps cannot keep up, the level rises to the setpoints of the other two pumps, which take over and rotate their sequence with each other.

Important Information

The pumps are started and stopped at the “ON” and “OFF” setpoints. To *pump down* (reduce level) then set “ON” higher than “OFF”. To *pump up* (increase level) then set “ON” lower than “OFF”.

The **third parameter** for each relay determines the pump group. You can have two groups of pumps, and all similar duties within a group will operate together.

P212, P222, P232, P242, P252, P262, P272, P282, P292, P572

Relay Pump Group

By **default**, all pump groups are set to **1**, but if you want to have another group, then set this parameter to **2**, for each pump relay that should operate together as part of a second group.

The **fourth parameter** and the **fifth parameter** for each relay set the **pump “ON”** and **“OFF”** points, which are entered in **Measurement units P104**. For *pump down* the **“ON”** is set **higher than “OFF”**. For *pump up* then **“ON”** is set **lower than “OFF”**. See the appropriate **pump duty**, function table (**P212, 222, 232, 242, 252, 262, 272, 282, 292, 572**) for further information.

P213, P223, P233, P243, P253, P263, P273, P283, P293, P573

Relay Setpoint 1

This parameter will determine the **“ON”** point of the pump(s).

P214, P224, P234, P244, P254, P264, P274, P284, P294, P574

Relay Setpoint 2

This parameter will determine the **“OFF”** point for the pump(s).

Relay setpoints 1 and 2 are entered in values of Measurement Units (P104) See the appropriate **pump duty** function, table (**P211, 221, 231, 241, 251, 261, 271, 281, 291, 571**), for further information.

The **sixth parameter** will determine the **service ratio** that will be used to switch the pump, when **pump duty** selected is a Service Ratio duty.

P211, 221, 231, 241, 251, 261, 271, 281, 291, 571 = 6, 7 or 9 (Service ratio)

P215, P225, P235, P245, P255, P265, P275, P285, P295, P575

Relay Setpoint 3

This parameter determines the Service Ratio in values of %. See the appropriate **pump duty** function, table (**P211, 221, 231, 241, 251, 261, 271, 281, 291, 571**), for further information.

P219, P229, P239, P249, P259, P269, P279, P289, P299, P579

Relay Max.Rate

This parameter will allow a **pump** to be **switched** at a pre-determined **Rate of change of Level**, irrespective of the **“ON”** level setpoint **P213, 223, 233, 243, 253, 263, 273, 283, 293, 573**. Once a pump relay has been switched **“ON”** by the pre-determined **Rate of Change**, it will remain energised until the level reaches the **“OFF”** level setpoint **P214, 224, 234, 244, 254, 264, 274, 284, 294, 574**.

Max. Rate is entered in Measurement Units (P104) per minute and can be entered in positive (increasing level) or negative (decreasing level) values.

Control

When P210, 220, 230, 240, 250, 260, 270, 280, 290, 570 = 3 (Control)

When a relay is being set up as a **control** relay, the **second parameter** that will be displayed in the menu determines its **function**.

P211, P221, P231, P241, P251, P261, P271, P281, P291, P571

Relay Function,

This function allows the relay to be assigned to specific **control** functions (other than pumps and alarms) several of these functions work in relation to time.

This can be used to activate devices based on elapsed time or running cycles, such as a timed rake control to keep a ram lubricated if idle for long periods, or flush valve operation.

Options	Description
0 = Off (Default)	Relay is always de-energised
1 = Time	Relay will energise “ON” after the Cycle time that is set in Relay Setpoint 2 (P214, 224, 234, 244, 254, 264, 274, 284, 294, 574). And turns “OFF” , de-energises , after the On Time Period that is set in Relay Setpoint 1 (P213, 223, 233, 243, 253, 263, 273, 283, 293, 573)
2 = Storm	Relay will energise “ON” when storm conditions are in effect and, de-energise “OFF” when storm conditions cease. Two setpoints are required, Upper Storm “ON” , (P213, 223, 233, 243, 253, 263, 273, 283, 293, 573) and Lower Storm, “OFF” (P214, 224, 234, 244, 254, 264, 274, 284, 294, 574). This allows the relay to be used to activate a device as a result of high levels such as a storm condition e.g. opening a gate valve to divert storm overflow into a holding vessel.

Options	Description
3 = Aeration	<p>Relay will energise “ON” after each Cycle time as set in Relay Setpoint 2 (P214, 224, 234, 244, 254, 264, 274, 284, 294, 574). And turns “OFF”, de-energises, after the set On Time Period as set in Relay Setpoint 1 (P213, 223, 233, 243,253, 263, 273, 283, 293, 573). This can be used to activate a device based upon elapsed time since All Pumps have been “OFF”, such as the introduction of fresh air to reduce gas concentration.</p>
4 = Flush Valve	<p>Relay will energise “ON” when Flush condition is in effect and goes off when Flush condition is cleared. A relay being used for Flush Valve/Pump must be assigned to one of the main pumps in use.</p> <p>Flush relay Alarm ID (P212, 222, 232, 242, 252, 262, 272, 282, 292, 572) is used to enter the relay number, to which the assigned pump is connected.</p> <p>Flush Valve/Pump relay requires three setpoints. The first set point (P213, 223, 233, 243, 253, 263, 273, 283, 293, 573) determines the Flush Interval, which is the number of main pump cycles that should occur before the Flush Valve/Pump operates. The second setpoint (P214, 224, 234, 244, 254, 264, 274, 284, 294, 574), sets the number of Flush cycles the Flush Valve/Pump will operate for. This means that the Flush Valve will be operated for a number of main pump starts (Flush Cycles) after which the Flush Valve activity will cease until the Flush Interval comes around again. Setpoint three of the Flush Valve/Pump relay sets the Flush Duration, (P215, 225, 235, 245, 255, 265, 275, 285, 295, 575) this is the duration for Flush Cycle, in seconds.</p>

Options	Description
5=Step Time	<p>Step Time Control allows relays to be used to control a device, such as a motorised valve or gate, in order to maintain the level within two predetermined points. Relays will energise “ON” when Step Time condition is in effect and de-energises “OFF” when Step Time goes off. One relay will be required to control an increase in level, (‘open’ the device) and a second relay is required to control a decrease in level, (‘close’ the device). Alarm ID (P212, 222, 232, 242, 252, 262, 272, 282, 292, 572) is used to assign the relay to control either the open or close condition. Step Time Control relay requires three setpoints. The first set point (P213, 223, 233, 243, 253, 263, 273, 283, 293, 573) determines the level, at which the relay is to be activated, (N.B. level setpoint for open relay, increase the level, must be lower than the setpoint for the close relay, decrease the level). The relay will energise “ON” after the Limit time that is set in Relay Setpoint 3 (P215, 225, 235, 245, 255, 265, 275, 285, 295, 575). And turns “OFF”, de-energises, after the Drive Period that is set in Relay Setpoint 2 (P214, 224, 234, 244, 254, 264, 274, 284, 294, 574).</p>
6 = Differential Control	<p>Relay will energise “ON” when a differential condition is in effect and, de-energise “OFF” when the differential conditions cease. Two setpoints are required, Differential control “ON”, (P213, 223, 233, 243, 253, 263, 273, 283, 293, 573) and Differential control, “OFF” (P214, 224, 234, 244, 254, 264, 274, 284, 294, 574).</p> <p>This allows the relay to be used to activate a device as a result of a differential level, between two points e.g. operate a rake on a</p>

Options	Description
7 = Pump Reset	Relay will energise “ON” for the period of the Reset Pulse (P309) after expiry of the Reset Interval (P308), provided the level is above the Prime Level (P349), to reset the designated pump that has tripped. Alarm ID (P212, 222, 232, 242, 252, 262, 272, 282, 292, 572) is used to enter the relay number , to which the designated pump is connected.

The **third parameter** for each relay determines the **assignment** or **condition** of the relay, where required.

P212, P222, P232, P242, P252, P262, P272, P282, P292, P572

Relay Alarm ID/Pump Group,

P211, 221, 231, 241, 251, 261, 271, 281, 291, 571 = 1, 2, 3 or 6

This parameter has no function and will not be displayed.

P211, 221, 231, 241, 251, 261, 271, 281, 291, 571 = 4 (Flush Valve)

If the relay is selected for Flush Valve/Pump, then this parameter is used to determine to which pump the Flush function is assigned. Enter the **relay number to which the assigned pump is connected**.

P211, 221, 231, 241, 251, 261, 271, 281, 291, 571 = 5 (Step Time)

If the relay is selected for Step Time, then this parameter is used to assign the relay to the 0 = **Open** condition (increase level) or 1 = **Close** condition (decrease level).

P211, 221, 231, 241, 251, 261, 271, 281, 291, 571 = 7 (Pump Reset)

If the relay is selected for Pump Reset, then this parameter is used to determine to which pump the Pump Reset function is assigned. Enter the **relay number to which the assigned pump is connected**.

The **fourth parameter**, **fifth parameter** and **sixth parameter** are set to determine the switch points, “ON” and “OFF” for the relay and where required the order of start. See **control function**, table (P211, 221, 231, 241, 251, 261, 271, 281, 291, 571) for further information.

P213, P223, P233, P243, P253, P263, P273, P283, P293, P573

Relay Setpoint 1

P211, 221, 231, 241, 251, 261, 271, 281, 291, 571 =1 (Time)

This parameter determines the “**Time Period**” that the relay will remain “ON”.

Relay Setpoints are entered in Minutes.

See the appropriate relay **Function** tables (P211, 221, 231, 241, 251, 261, 271, 281, 291, 571) for further information.

P211, 221, 231, 241, 251, 261, 271, 281, 291, 571 = 2 (Storm)

Relay Setpoint 1 is entered in values of **Measurement Units (P104)**

See the appropriate relay function tables (P211, 221, 231, 241, 251, 261, 271, 281, 291, 571) for further information.

P211, 221, 231, 241, 251, 261, 271, 281, 291, 571 = 3 (Aeration)

Relay Setpoint 1 is entered in Minutes to set **Cycle Time**

See the appropriate relay **Function** tables (P211, 221, 231, 241, 251, 261, 271, 281, 291, 571) for further information.

P211, 221, 231, 241, 251, 261, 271, 281, 291, 571 = 4 (Flush Valve)

Relay Setpoint 1 is entered in Pump cycles to set **Flush Interval**.

See the appropriate relay **Function** tables (P211, 221, 231, 241, 251, 261, 271, 281, 291, 571) for further information.

P211, 221, 231, 241, 251, 261, 271, 281, 291, 571 =5 (Step Time)

Relay Setpoint 1 is entered in values of **Measurement Units (P104)**

See the appropriate relay function tables (P211, 221, 231, 241, 251, 261, 271, 281, 291, 571) for further information.

P211, 221, 231, 241, 251, 261, 271, 281, 291, 571 =6 (Differential)

Relay Setpoint 1 is entered in values of **Measurement Units (P104)**

See the appropriate relay function tables (P211, 221, 231, 241, 251, 261, 271, 281, 291, 571) for further information.

P211, 221, 231, 241, 251, 261, 271, 281, 291, 571 = 7 (Pump Reset)

This parameter has no function and will not be displayed.

P214, P224, P234, P244, P254, P264, P274, P284, P294, P574

Relay Setpoint 2

P211, 221, 231, 241, 251, 261, 271, 281, 291, 571 = 1 (Time)

This parameter determines the “**Cycle Time**” for the operation of the relay.

See the appropriate relay **Function** tables (**P211, 221, 231, 241, 251, 261, 271, 281, 291, 571**) for further information.

P211, 221, 231, 241, 251, 261, 271, 281, 291, 571 = 2 (Storm)

Relay Setpoints are entered in values of **Measurement Units (P104)**

See the appropriate relay **Function** tables (**P211, 221, 231, 241, 251, 261, 271, 281, 291, 571**) for further information.

P211, 221, 231, 241, 251, 261, 271, 281, 291, 571 = 3 (Aeration)

Relay Setpoints are entered in Minutes to set **Time Period** that the relay will remain ON

See the appropriate relay **Function** tables (**P211, 221, 231, 241, 251, 261, 271, 281, 291, 571**) for further information.

P211, 221, 231, 241, 251, 261, 271, 281, 291, 571 = 4 (Flush Valve)

Relay Setpoints are entered in cycles to set the number of **Flush cycles**.

See the appropriate relay **Function** tables (**P211, 221, 231, 241, 251, 261, 271, 281, 291, 571**) for further information.

P211, 221, 231, 241, 251, 261, 271, 281, 291, 571 = 5 (Step Time)

Relay Setpoints are entered in Seconds to set **Drive Period**, the time that the relay will remain ON

See the appropriate relay **Function** tables (**P211, 221, 231, 241, 251, 261, 271, 281, 291, 571**) for further information.

P211, 221, 231, 241, 251, 261, 271, 281, 291, 571 = 6 (Differential)

Relay Setpoints are entered in values of **Measurement Units (P104)**

See the appropriate relay **Function** tables (**P211, 221, 231, 241, 251, 261, 271, 281, 291, 571**) for further information.

P211, 221, 231, 241, 251, 261, 271, 281, 291, 571 = 7 (Pump Reset)

This parameter has no function and will not be displayed.

P215, P225, P235, P245, P255, P265, P275, P285, P295, P575

Relay Setpoint 3

P211, 221, 231, 241, 251, 261, 271, 281, 291, 571 = 1, 2, 3, 6 or 7

This parameter has no function and will not be displayed.

P211, 221, 231, 241, 251, 261, 271, 281, 291, 571 = 4 (Flush Valve)

Enter desired **Flush duration** in seconds.

See the appropriate relay **Function** tables (**P211, 221, 231, 241, 251, 261, 271, 281, 291, 571**) for further information.

P211, 221, 231, 241, 251, 261, 271, 281, 291, 571 = 5 (Step Time)

This parameter is used to determine the **Limit Time** between each Drive Period. Relay Setpoints are entered in Minutes, during which time the relay will remain OFF.

See the appropriate relay **Function** tables (**P211, 221, 231, 241, 251, 261, 271, 281, 291, 571**) for further information.

Miscellaneous

When P210, 220, 230, 240, 250, 260, 270, 280, 290, 570 = 4 (Miscellan.)

When a relay is set to be **miscellaneous** relay, the **second parameter** determines its **function**.

P211, P221, P231, P241, P251, P261, P271, P281, P291, P571

Relay Function,

This function allows the relay to work in relation to a clock and will be set to activate in relation to Real Time or to provide a pulsed output in relation to a predetermined count from the totaliser, the choices being as follows:

Options	Description
0 = Off (Default)	Relay Off de-energised
1 = Clock	Relay will energise ON at a specified time each day as set in Relay Setpoint 1 (P213, 223, 233, 243, 253, 263, 273, 283, 293, 573). And turns OFF, de-energises , after the specified On Time period as set in Relay Setpoint 2 (P214, 224, 234, 244, 254, 264, 274, 284, 294, 574)
2 = Totaliser	Relay will energise ON momentarily each time the specified flow has passed as set in Relay setpoint 1 (P213, 223, 233, 243, 253, 263, 273, 283, 293, 573), this parameter sets the multiplication factor which will be applied to the on board totaliser (P820) to determine the switch point of the relay. E.g. if the totaliser is set to totalise in cubic metres and the relay is required to provide a closure every 10,000 litres Relay setpoint 1 would be set to 10. Relay setpoint 2 (P214, 224, 234, 244, 254, 264, 274, 284, 294, 574) can be used to select the time the relay will remain closed in seconds.

Important Information

When using a Relay to control a device at a specified time of day ensure that the **Time P932** is set correctly. And if required, enable **Daylight Saving** for the appropriate time difference **P970 – P979**.

The **third parameter** has **no function** when **miscellaneous relay** is chosen and will not be displayed.

The **fourth parameter**, and **fifth parameter**, are set to determine the switch points, “**ON**” and “**OFF**” for the relay. See **miscellaneous** function table (**P211, 221, 231, 241, 251, 261, 271, 281, 291, 571**) for further information.

P211, 221, 231, 241, 251, 261, 271, 281, 291, 571 = 1 (Clock)

P213, P223, P233, P243, P253, P263, P273, P283, P293, P573

Relay Setpoint 1

Relay Setpoints are entered in Hours & Minutes (HH:MM) to set Time at which relay will energise. **Default = 00:00 (HH:MM)**

P214, P224, P234, P244, P254, P264, P274, P284, P294, P574

Relay Setpoint 2

Relay Setpoints are entered in Minutes to set Time Period that the relay will remain ON. **Default = 0.00 mins.**

P211, 221, 231, 241, 251, 261, 271, 281, 291, 571 = 2 (Totaliser)

P213, P223, P233, P243, P253, P263, P273, P283, P293, P573

Relay Setpoint 1

Relay Setpoints are entered as a factor by which the on board totaliser (P820) should be multiplied by to provide a relay closure. **Default = 0.00**

P214, P224, P234, P244, P254, P264, P274, P284, P294, P574

Relay Setpoint 2

Relay Setpoints are entered in **seconds** to set the **time period** that the relay will remain ‘ON’. **Default = 0.00 secs.**

Pump by Time

When a relay is assigned to Pump by Time the pump will come on (energise) at its normal “**ON**” level setpoint, and de-energise at its **OFF level** setpoint or after a predetermined **time** period, **whichever occurs first**.

P210, 220, 230, 240, 250, 260, 270, 280, 290, 570 = 5 (Pump by Time)

When a relay is being used for a **pump by time** function, the **second parameter** determines the **pump duty** that will be used to determine the operating cycle.

P211, P221, P231, P241, P251, P261, P271, P281, P291, P571

Relay Function,

This parameter defines which **pump duty** the relay should respond to as follows.

Pump Duty	Description
0= Off (Default)	Relay is always de-energised.
1= Fixed duty assist	All pumps are used to assist each other (run at the same time) and each pump has its own setpoints. (P213, 223, 233, 243, 253, 263, 273, 283, 293, 573 & P214, 224, 234, 244, 254, 264, 274, 284, 294, 574).
2= Fixed duty backup	If a pump fails to meet the demand (due to malfunction, intake blockage etc.), then it is stopped and another pump shall take over. Each pump has its own setpoints. (P213, 223, 233, 243, 253, 263, 273, 283, 293, 573 & P214, 224, 234, 244, 254, 264, 274, 284, 294, 574).
3= Alternate duty assist	All pumps are used to assist each other (run at the same time). Each pump has its own setpoints, (P213, 223, 233, 243, 253, 263, 273, 283, 293, 573 & P214, 224, 234, 244, 254, 264, 274, 284, 294, 574) but each time all pumps have stopped, the setpoints are sequentially rotated between the pumps to ensure equal pump use.

Pump Duty	Description
4= Alternate duty backup	If a pump fails to meet the demand (due to malfunction, intake blockage etc.), then it is stopped and another pump shall take over. Each pump has its own setpoints, (P213, 223, 233, 243, 253, 263, 273, 283, 293, 573 & P214, 224, 234, 244, 254, 264, 274, 284, 294, 574). but each time all pumps have stopped, then the setpoints are sequentially rotated between the pumps to ensure equal pump use.
5= Duty backup and assist	First pump comes on, if it cannot cope, it goes off and next pump comes on (duty backup). This continues until the last pump comes on and if it cannot cope the first pump comes back on to assist the last pump (duty assist) if the level continues to rise all other pumps will come on (assist) in turn until the level decreases to the pump off points. Each pump has its own setpoints, (P213, 223, 233, 243, 253, 263, 273, 283, 293, 573 & P214, 224, 234, 244, 254, 264, 274, 284, 294, 574).

Important Information

The pumps are started and stopped at the “ON” and “OFF” setpoints. To *pump down* (reduce level) then set “ON” higher than “OFF”. To *pump up* (increase level) then set “ON” lower than “OFF”.

The **third parameter** for each relay determines the pump group. You can have two groups of pumps, and all similar duties within that group will operate together.

P212, P222, P232, P242, P252, P262, P272, P282, P292, P572

Relay Pump Group

By **default**, all pump groups are set to **1**, but if you want to have another group, then set this parameter to **2**, for each pump relay that should operate together as part of a second group.

The **fourth parameter**, and the **fifth parameter** for each relay set the **pump “ON”** and **“OFF”** points, which are entered in **Measurement units P104**. For *pump down* the **“ON”** is set **higher than “OFF”**. For *pump up* then **“ON”** is set **lower than “OFF”**. See the appropriate **pump duty**, function table (**P212, 222, 232, 242, 252, 262**) for further information.

P213, P223, P233, P243, P253, P263, P273, P283, P293, P573

Relay Setpoint 1

This parameter determines the **“ON”** point of the pump.

P214, P224, P234, P244, P254, P264, P274, P284, P294, P574

Relay Setpoint 2

This parameter determines the **“OFF”** point for the pump.

When a relay is being used for a **pump by time** function, then the **sixth parameter** will determine the maximum time the pump will be allowed to run before it is switched off and the next pump takes over.

P215, P225, P235, P245, P255, P265, P275, P285, P295, P575

Relay Setpoint 3

This parameter determines the **Maximum Time** the pump will be allowed to **run** before being switched **“OFF”** and is entered in minutes.

The pump will switch off either at its **“OFF”** level **Relay Setpoint 2** (**P214, 224, 234, 244, 254, 264, 274, 284, 294, 574**) or its **Maximum Run Time Relay Setpoint 3** (**P215, 225, 235, 245, 255, 265, 275, 285, 295, 575**), whichever occurs **first**.

Common Parameters

P217, P227, P237, P247, P257, P267, P277, P287, P297, P577

Relay Closures

The **Quantum³** will record how many times each relay has operated, this parameter displays the number of times the relay has activated since the relay has been in use. It can be reset with any value.

P218, P228, P238, P248, P258, P268, P278, P288, P298, P578

Relay Fail Safe

Your **Quantum³** has a general fail-safe parameter P808. However, this can be overridden so that each individual relay has its own independent fail-safe mode.

Option	Description
0 = Default	Relay assumes system default mode P808
1 = Hold	Relay will remain in its current state
2 = De-energise	Relay will De-energise
3 = Energise	Relay will Energise

Pump Trips

When using digital inputs to monitor pump running status and assign relays to “Pump Reset” this function allows for a pre-programmed number of pump “fails” (P307 Trip limit) to be automatically reset before putting a pump out of service.

A pump “fail” is defined as the change of state of the trip signal from normal condition to failed. At the point of failure both the consecutive trip counter and the 24 hour rolling counter will be advanced by an increment of 1. After any such pump “fail” is observed the unit will initiate a “cooling” down period (P308 Reset Interval) before initiating an automatic reset (Reset Pulse P309), provided the level in the sump is above the specified minimum level (Prime Level P349).

At this point, the pump has been reset and will operate as normal the next time its 'ON' setpoint is reached. If the pump then successfully pumps to its 'OFF' setpoint, thereby completing a successful pump cycle, then the consecutive trip counter will be reset and the 24 hour rolling counter preserved. When any Pump Trip counter exceeds the number of trips allowed (P307 Trip Limit) in any rolling 24 hour period, starting with the first increment of the Trip counter or the pump fails consecutively, exceeding the number of consecutive trips (Maximum Attempts P300) without completing a successful pump cycle, that pump will be put out of service and will not be rest until such time that the fail condition is removed.

P307 Trip Limit

This parameter sets the maximum number of pump “fails” allowed in any 24-hour rolling period.

P308 Reset Interval

This parameter sets the “cooling” off period prior to a Reset Pulse being initiated.

P309 Reset Pulse

This parameter determines the duration of the Reset Pulse.

P310 Pump 1 Trip

This parameter is a “Read Only” parameter and displays the number of times that Pump 1 has “tripped” since the last successful Reset was performed.

P311 Pump 2 Trip to P319 Pump Trip 10

These parameters are “Read Only” and display the same information as

P310 Pump Trip 1 for Pump Trip 2 to 10.

Pump “Advanced” Parameters

The following parameters are used to set the “Advanced” Pump features.

Pump Run On

This feature is used to periodically allow the pumps to continue operating below their normal “OFF” point, in order to discharge any sediment that may have settled at the bottom of the vessel.

P349 Prime Level

Sets the required level to ensure pumps are fully primed after a pump run on has occurred. Following a pump run on, any pump, whose “ON” point is below the Prime Level will be held “OFF” until the Prime Level has been exceeded.

P350 Run Interval

Set required time period, in hours, at which pump run on should occur.

P351 Run Duration

This parameter sets the length of time, in seconds, that pumps will run on for, it should be noted that only one run on is allowed per Run Interval.

Starting

This feature is used to reduce the effects of power surges, caused by switching of pumps, in the following instances, **(P352) Power surge** (mains or hydraulic) that is generated when multiple pumps are started simultaneously, **(P353) Power resumption** following a power failure.

P352 Start Delay

Set the required time period, in seconds, that should elapse between pumps starting. **Default = 10 seconds.**

P353 Power Delay

Set the required time period, in seconds, that should elapse before pumps are allowed to start following a power failure. **Default = 10 seconds.**

Stopping

If required, this feature will **prevent** pumps, with a **common “OFF” point** being switched off all at the same time pumps will be switched “OFF” in turn as determined by the **delay** set in **P348 Stop Delay**.

P348 Stop Delay

Set the required time period, in seconds, that should elapse between pumps stopping. **Default = 0.0 seconds**.

Pump Exercising

This feature is used to reduce idle pump corrosion and sediment build up. Pumps are allowed to run after a specified **Idle Time (P355)** for a determined period of **Exercise time (P356)**, providing a **Minimum head /level (P357)** is present and all other pumps are switched off.

P354 Exercise Enable

This parameter determines if Pump Exercising is enabled or disabled.

Option	Description
0 = No (Default)	Pump Exercising disabled
1 = Yes	Pump Exercising enabled

P355 Idle Time

Sets the Idle Time to elapse before Pump Exercising is to be activated.

Set the required time period in minutes. **Default = 720 minutes**

P356 Exercise Time

Set the required Exercise Time in seconds. **Default = 30 seconds**

P357 Minimum Head

To prevent the dry running and the possibility of cavitation, of the pump, enter the minimum level (head) of material, in metres, that is to be present before permitting pump exercising to take place.

Wall Cling

To reduce material build up (such as fat), on the wall of the sump or vessel, at the “normal” material level the pump setpoints can be varied within a specified band.

For Pump Down applications the relay setpoints for the pumps will be randomly varied within the band specified, somewhere below ON, but to a maximum of the setting, and somewhere higher than OFF, but to a maximum of the setting.

For Pump Up applications the relay setpoints for the pumps will be randomly varied within the band specified somewhere higher than ON, but to a maximum of the setting, and somewhere lower than OFF, but to a maximum of the setting.

P360 Wall Cling

Enter the maximum band, of variation, required in metres.

Storm

This facility enables all pumps to be **disabled (P370)** during a storm condition to prevent the futile running or potential damage due to the continued use of pumps during flood conditions. Provision is also made to allow a maximum **time period (P371)** for which pumps will remain disabled during such conditions. For this function to operate a relay must have been assigned to Storm and have Upper and Lower storm setpoints set. See **P210, 220, 230, 240, 250 = 3 (Control) P211, 221, 231, 241, 251, Relay Function =2 (Storm)** for further details.

P370 Pump Disable

This parameter sets the action required during a flood condition.

Option	Description
0 = Disabled	Pumps Disabled during Storm condition.
1 = Normal (Default)	Normal Pump operation during Storm condition

P371 Disable Time

This parameter will set the maximum time pumps will remain disabled if P370 = 0 Enter desired time in minutes. **Default = 30 minutes**

Rate Method

The following parameters are used in conjunction with the RMA function.

P116 Rate Calc

This is only available when P118 is set to 1 = Derived. It is used to set whether you wish to set RMA's using a linear velocity or a volumetric flow.

Option	Description
0 = Linear	Linear velocity selected.
1 = Volume (Default)	Volumetric flow is selected

P117 RMA Delay

This parameter determines the delay in cycles before the RMA function is activated after power up (after the first ping), returning to run mode from program mode or after a pump failure i.e. an alarm won't be considered until after this delay. **Default = 0.**

P118 Output Flow

This parameter is used to determine which method of flow is used by the Quantum³.

Option	Description
0 = FlowPulse (Default)	FlowPulse is used for the flow
1 = Derived	Derived flow calculates the flow.

Changing this parameter changes the method the Quantum³ uses for its source for flow/rate. The default for the Quantum³ is FlowPulse.

FlowPulse

FlowPulse is an ultrasonic non-invasive flow monitor that supplies the Quantum³ with real time flow. Using FlowPulse eliminates the need to calculate the inflow rates meaning that changes in to inflow with not affect the calculated outflow. By using the FlowPulse you gain access to both NRV alarms and Storm alarms, neither of which can be achieved by using derived flow.

Derived Flow

Derived flow is the method of calculating the flow rate based on rate of change in level. While the pumps are not running the inflow is calculated by taking an average of the rate of change. At the point in which a pump cycle begins the inflow value at that point is used as a constant throughout that cycle. The rate of change throughout the pumping cycle is then subtracted from the inflow to give the pumping rate/flow.

Digital Inputs

About Digital Inputs

The digital inputs are used to provide the Quantum³ with information on the operational status and condition of pumps, valves, and other process control devices. Based on the information supplied, by the inputs, the Quantum³ will make intelligent decisions and modify its control regime to meet the demand of the prevailing operational requirements.

The parameters used to program the Digital inputs are as follows:

Common Parameters P300 to P306

Digital Input 1 P372 to 374

Digital Input 2 P375 to 377

Digital Input 3 P378 to 380

Digital Input 4 P381 to 383

Digital Input 5 P384 to 386

Digital Input 6 P387 to 389

Digital Input 7 P390 to 392

Common Parameters Set-up

These parameters determine specific operational criteria for particular digital input functions and are common to each digital input.

Input Type

The digital inputs can be either voltage source, where Quantum³ will supply the switching voltage, or voltage synch, where the switching voltage is supplied by the input from the device, for full details see **Chapter 2 Installation**. Both voltage source and voltage synch. inputs can be configured for **N.O.** or **N.C.** operation as determined by the digital input **Type P372, 375, 378, 381, 384, 387, 390** when set to **1= Input N.C.**, Quantum³ will recognise a **closed** condition, D.C. **signal** voltage **present** at input, as a healthy condition, alternatively, an **open** condition, D.C. **signal** voltage **not present** at input, indicating a healthy condition, can be chosen as a valid input by selecting **2=Input N.O.**

Input Function

Individual inputs can be configured for any one of a number of **Functions** as determined by **P373, 376, 379, 382, 385, 388, 391** these functions are as follows:

- 1 = Device Fail** input will provide a signal indicating a “failure” or the presence of a “run” signal from the device. When using digital inputs to detect a “run” condition the input is assumed to be in its operational status until the expiry of **P304 Input Delay** which is used to determine the delay time that occurs from the time that the device is called to “run” and the digital input providing a signal appropriate to its operational status.
- 2 = Duty** input will provide a signal to manually select the lead device.
- 3 = Override ON** input will provide a signal to override all selected pump setpoints “ON”.
- 4 = Override OFF** input will provide a signal to override all selected pump setpoints “OFF”.
- 5 = Reset** input will provide a signal to reset all Device Fail signals.

Device Fail

The digital inputs are used to indicate a ‘fail’ situation which effect devices, which are connected to the relay outputs of the Quantum³, e.g. failure of a pump, screen, valve, etc. This information is then used to initiate changes to the Quantum³'s control regime to meet the demands of the situation.

Let us consider the example of an application using 2 pumps, each pump has the capability to provide a signal indicating its ‘run’ status. Each pump is connected and controlled by one of the Quantum³ relay outputs, the duty and setpoints have been programmed as detailed in **Using the Relays**, earlier in this chapter. The signals providing details on the pumps ‘run status’ are connected to the digital inputs as described in **Chapter 2 Installation**, and the input **Type P372, 375, 378, 381, 384, 387, 390** is configured as detailed in **Input Type**, earlier in this chapter.

Pump 1 is connected and programmed to operate on **Relay 1**

Pump 2 is connected and programmed to operate on **Relay 2**

Pump 1 Fail signal is connected to **Digital Input 1**

Pump 2 Fail signal is connected to **Digital Input 2**

Each digital input has to be assigned to the device relay output that it relates to, this is determined by **Assignment P374, 377, 380, 383, 386, 389, 392**. In the case of our example **Digital Input 1** will be assigned to **Relay 1 (P374 = 1)** and **Digital Input 2** will be assigned to **Relay 2 (P377 = 2)**.

When the level rises to the ON Setpoint of Relay 1, the relay will energise and Pump 1 will ‘start’, in the normal manner. If the pump starts and runs correctly no change of ‘run’ status will be seen on the digital input and the pump(s) will be allowed to operate as programmed.

Should a pump **fail**, a change of ‘run’ status would be seen and a **Device Fail**, condition would be detected on the corresponding digital input, this will result in the relay for the ‘failed’ pump being de-energised and the pump being switched OFF. The setpoints of the ‘failed’ pump will then be passed to the second pump, which will take over to complete the pumping operation.

The decision on whether or not to attempt to start the failed pump on subsequent pump cycles will be determined by **P300 Max. Attempts**. Once the number of attempts stipulated have been made the pump will be put out of service until such time the Device Fail input is cleared by a **Reset (P391 = 4)** on Digital Input 7. Alternatively the **+/-** key can be used as a Hot Key, which when pressed, whilst the unit is in RUN, will give details of any **Device Fail** and provides prompts to **Reset** any failures to the **no fault** condition.

Duty

When this function is selected the digital inputs are used to determine, via an ‘auto/manual’ switch, which one of the devices, connected to the relay outputs of the Quantum³, will be the “lead” or “duty” device.

Consider the example of an application using 2 pumps. Each pump is connected and controlled by one of the Quantum³ relay outputs, the pump duty and setpoints have been programmed as detailed in **Using the Relays**, earlier in this chapter. The signals providing details on the “lead” or “duty” pump ‘status’ are connected to the digital inputs as described in **Chapter 2 Installation**, and the input **Type P372, 375, 378, 381, 384, 387, 390** is configured as detailed in **Input Type**, earlier in this chapter.

Pump 1 is connected and programmed to operate on **Relay 1**

Pump 2 is connected and programmed to operate on **Relay 2**

Pump 1 Duty signal is connected to **Digital Input 3**

Pump 2 Duty signal is connected to **Digital Input 4**

The type of switch to be used to determine the duty is selected and configured as detailed in **P301 Switch Mode**.

Standard Switch Mode (P301 = 0 Standard)

When a standard rotary type switch is used, to determine auto/manual duty one input per device is required, with each input being assigned to the appropriate device relay output that it relates to, this is determined by **Assignment P374, 377, 380, 383, 386, 389, 392**. In the case of our example **Digital Input 3** will be assigned to **Relay 1 (P380 = 1)** and **Digital Input 4** will be assigned to **Relay 2 (P383 = 2)**.

When the **duty switch** is in the “**auto**” position, no signals are present on either Digital Input 3 or Digital Input 4 and devices will run in the “**auto**” mode, as determined by the Quantum³, in accordance with its programmed settings. If a signal is seen on Digital Input 3, **duty switch** selected for **Pump 1**, then the pump connected to Relay 1 will assume the role of “**lead**”/”**duty**” pump, regardless of the settings programmed in the Quantum³.

When the level rises to the **ON Setpoint**, for the **first** pump, relay 1 will energise and Pump 1 will ‘start’, in the normal manner. If the level continues to rise then relay 2 will energise and Pump 2 will start in accordance with the settings programmed for pump 2.

If a signal is seen on Digital Input 4, **duty switch** selected for **Pump 2**, then the pump connected to Relay 2 will assume the role of “**lead**”/”**duty**” pump, regardless of the settings programmed in the Quantum³. When the level rises to the **ON Setpoint**, for the **first** pump, the relay 2 will energise and Pump 2 will ‘start’, in the normal manner. If the level continues to rise then relay 1 will energise and Pump 1 will start in accordance with the settings programmed for pump 2.

Binary Switch Mode (P301 = 1Binary)

When a binary switch is used, to determine auto/manual duty, the number of inputs required will be dependent on the number of devices to be included in the duty selection. In this mode the duty device will be selected according to the binary input present on the appropriate inputs and there is therefore no requirement to assign the duty switch inputs to specific device relay. The selection of the Lead/Duty device is determined by the presence of an input as detailed in the table below, where **0** = **no input** present and **1** = **input** present.

Duty Input 1	Duty Input 2	Duty Input 3	Duty Input 4	Lead/Duty Device
0	0	0	0	Auto
1	0	0	0	Relay 1
0	1	0	0	Relay 2
1	1	0	0	Relay 3
0	0	1	0	Relay 4
1	0	1	0	Relay 5
0	1	1	0	Relay 6
1	1	1	0	Relay 7
0	0	0	1	Relay 8
1	0	0	1	Relay 9
0	1	0	1	Relay 10

Consider the example of an application using 2 pumps. Each pump is connected and controlled by one of the Quantum³ relay outputs, the pump duty and setpoints have been programmed as detailed in **Relays**, earlier in this chapter. The signals providing details on the “lead” or “duty” pump ‘status’ are connected to the digital inputs as described in **Chapter 2 Installation**, and the input **Type P372, 375, 378, 381, 384, 387, 390** is configured as detailed in **Input Type**, earlier in this chapter.

Pump 1 is connected and programmed to operate on **Relay 1**

Pump 2 is connected and programmed to operate on **Relay 2**

Duty Input 1 signal is connected to **Digital Input 3**

Duty Input 2 signal is connected to **Digital Input 4**

When no signals are present on either Digital Input 3 or Digital Input 4 then devices will run in the “**auto**” mode, as determined by the Quantum³, in accordance with its programmed settings. If a signal is seen on Digital Input 3, **duty** selected for **Pump 1**, then the pump connected to Relay 1 will assume the role of “lead”/”duty” pump, regardless of the settings programmed in the Quantum³. When the level rises to the **ON Setpoint**, for the **first** pump, relay 1 will energise and Pump 1 will ‘start’, in the normal manner. If the level continues to rise then relay 2 will energise and Pump 2 will start in accordance with the settings programmed for pump 2.

If a signal is seen on Digital Input 4, **duty** selected for **Pump 2**, then the pump connected to Relay 2 will assume the role of “lead”/”duty” pump, regardless of the settings programmed in the Quantum³. When the level rises to the **ON Setpoint**, for the **first** pump, the relay 2 will energise and Pump 2 will ‘start’, in the normal manner. If the level continues to rise then relay 1 will energise and Pump 1 will start in accordance with the settings programmed for pump 2.

Override

A digital input can be assigned to receive an input, which will **override** the setpoints of the pumps and **start** them, as determined by the **Override Level (P306)** and providing the level is above **the Min. Override (P303)**, immediately after the expiry of the **Override Delay (P302)**. A digital input can also be assigned to receive an input, which will **override** the setpoints of the pumps and **stop** them immediately after the expiry of the **Override Delay (P302)**.

Reset

This option is only available on Digital Input 7 **P391 = 5** when selected a valid signal received on this input will **Reset** all **Device Fail** signals to the **no fault** condition. When using this function the unit will check all inputs for such conditions so there is no requirement to assign the input to a specific relay output. Alternatively the **+/-** key has been allocated as a Hot Key , which when pressed will give details of any **Device Fail** and provides prompts to **Reset** any failures to the **no fault** condition.

Digital Input Parameters

Common Par.

These parameters are common to each of the seven digital inputs and set specific operational criteria for particular functions.

P300 Max.Attempts

When digital inputs are used to detect device failure this parameter determines the number of attempts that will be made before failing the device and putting it out of service. When the number of attempts is set to ‘0’, there is no restriction on the number of starts. The digital inputs will provide a fail signal in the normal manner and initiate any action as required, but the device will not be put out of service. Any figure other than 0 will determine the number of attempts that will be made to start the device before putting it out of service until such time that the input is reset.

Set the number of attempts Min. 0, Max 99.

P301 Switch Mode

When an external duty switch is used this can be connected via the digital inputs and facilitate the selection of the duty device manually, thereby overriding the duty programmed within the unit.

This parameter determines the type of switch in use.

Option	Description
0 = Standard (Default)	A standard switch, e.g. rotary switch, can be used with one switch position and a digital input required for each pump.
1 = Binary	To reduce the number of digital inputs used, for manual duty selection, a binary switch can be supplied. Max. No. of digital inputs required being four.

P302 Override Delay

A digital input can be assigned to receive an input, which will override the setpoints of the pumps and start or stop them, immediately after the expiry of the Override Delay, dependent on the selected Digital Input **Function P373, 376, 379, 382, 385, 388, 391 = 3 (Override “ON”) or 4 (Override “OFF”)** and providing the level is above the **Min. Override (P303)**, when **Override “ON”** is selected.

Enter the required delay time in minutes.

P303 Min Override

Determines the minimum level required before an **Override Delay (P302)** will be in effect when Digital Input **Function P373, 376, 379, 382, 385, 388, 391 = 3 (Override “ON”)**.

Enter the required level in **Measurement Units (P104)**.

P304 Input Delay

This parameter determines the delay applied, from the time a device (relay) is called to “run” and when the status of the digital input is recognised as a valid input. If the digital input is used to detect a “running” signal this parameter should be set to reflect the time it takes from the device being called to “run” to the input being in its operational status.

Enter the required time in seconds.

P305 Input Filter

This parameter is used to ignore spurious changes of state on the digital inputs and determines the time that a change of state has to be present before it is recognised as a valid input.

Enter the required time in seconds.

P306 Override Level

This parameter will determine which pumps setpoints will be overridden when Digital Input **Function P373, 376, 379, 382, 385, 388, 391 = 3 (Override “ON”)**. Only pumps with, **normal “ON”**, setpoints **below the Override Level** will be activated when an **Override “ON”** condition exists and that the **Override Delay (P302)** and **Min Override (P303)**, where required, have been satisfied.

Enter the required level in **Measurement Units (P104)**.

Digital Input

The following parameters are used to configure the use of the digital inputs.

P372, 375, 378, 381, 384, 387, 390 Type

Determines the way digital inputs will be recognised by Quantum³.

Option	Description
1 = Input N.C. (Default Input 1 – 6)	Quantum ³ recognises a closed condition, D.C. signal voltage present at the input , as a healthy/run condition.
2 = Input N.O. (Default Input 7)	Quantum ³ recognises an open condition, D.C. signal voltage not present at the input, as a healthy/run condition.

P373, 376, 379, 382, 385, 388, 391 Function

This parameter will set the function of the digital Input.

Option	Description
1=Device Fail (Default Input 1 – 6)	Digital input is used to Fail, (put out of service), a device connected to the relay specified in P374, 377, 380, 383, 386, 389, 392 Assignment .
2 = Duty	Digital input is used to select the device, (pump), connected to the relay specified in P374, 377, 380, 383, 386, 389, 392 Assignment as the current duty device (pump).
3 = Override “ON”	Digital input is used to provide a signal to activate an Override “ON” condition of pumps as determined by P302 Override Delay, P303 Min. Override and P306 Override Level .
4 = Override “OFF”	Digital input is used to provide a signal to activate an Override “OFF” condition of pumps after the expiry of the delay time as determined by P302 Override Delay .
5 = Reset. Digital Input 7 only. (Default Input 7)	Input is used to Reset all Device Fail conditions. Alternatively, the +/- key can be used, whilst in RUN , to Reset any Device Fail .

P374, 377, 380, 383, 386, 389, 392 Assignment

This parameter assigns the digital input to the appropriate device relay that the **Function**, (P373, 376, 379, 382, 385, 388, 391), is to be applied, where appropriate.

Option	Description
0 = None (Default)	Digital Input is not assigned to any relay.
1 = Relay 1	Digital input is assigned to Device connected to Relay 1.
2 = Relay 2	Digital input is assigned to Device connected to Relay 2.
3 = Relay 3	Digital input is assigned to Device connected to Relay 3.
4 = Relay 4	Digital input is assigned to Device connected to Relay 4.
5 = Relay 5	Digital input is assigned to Device connected to Relay 5.
6 = Relay 6	Digital input is assigned to Device connected to Relay 6.
7 = Relay 7	Digital input is assigned to Device connected to Relay 7.
8 = Relay 8	Digital input is assigned to Device connected to Relay 8.
9 = Relay 9	Digital input is assigned to Device connected to Relay 9.
10 = Relay 10	Digital input is assigned to Device connected to Relay 10.

Float Switch (FS) Backup

About Float Switch Backup

This digital feature is used with a float switch, where it can be used alongside a transducer or as a backup method for when a transducer goes into failsafe.

The high input will have a timer and a level set point, which will allow for the unit to power on every pump below the set point for the specified amount of time as set in **P332 Pump Run Time**.

The low input will simply switch off all the pumps that have been set on the controller.

Common Par

P330 Mode of Operation

Option	Description
0 = Off (default)	Float Switch Backup is not used
1 = Always	Backup will be active continuously and will respond to an input from a Backup device at all times.
2 = On Xdr Fail	Backup will only be active at times when the unit has gone into a Failsafe mode.

P330 Input Filter

This parameter can be used to ignore spurious changes of state on the digital inputs, and determines the time that a change of state has to be present before it is recognised as a valid input.

Enter a value in seconds: Min = 1 (**Default**), Max = 999.

P330 Pump Run Time

This parameter tells the unit to switch the pumps off after the specified amount of time, if the level of the float switch has not been reached.

Enter a value in minutes: Min = 0.1 (**Default**), Max = 9999.

Tariff Guard

Set Up

P393 Enable

This parameter determines if Energy Saving is in use or not.

Option	Description
0 = Off (Default)	Energy Saving is switched Off
1 = On	Energy Saving is switched On

'Tariff active' will appear on the Aux display of the unit when unit is in Tariff Guard mode. This feature is available from firmware version 7.5.1 and onwards.

P394 Lead Time

This parameter determines the time, prior to a High Tariff period, at which the vessel will be pumped down to the lowest pump OFF level.

Enter desired time in minutes.

P395 Lag Time

This parameter determines the time, after a High Tariff period, that the vessel will be pumped down, (if required), by the first duty pump to the lowest pump Off level. If after the Lag Time has expired the pump has not reached its Off point it will continue to pump until the Off point is reached. On expiry of the Lag Time all pumps will assume their normal operation and will be switched On and Off according to their respective setpoints.

Enter desired time in minutes.

P396 Min. Pump Run

This parameter determines the minimum amount of time that a pump will be allowed to run during a High Tariff period, if required, and is used to prevent excessive wear or damage to the pump.

Enter desired time in seconds.

P397 Minimum Head

This parameter determines the minimum head (level) of material required to be present before a pump will be allowed to run, if required, during a High Tariff period and is used to ensure that a prime level for the pumps is maintained.

Enter desired level in **Measurement Units (P104)**.

P398 Overflow Level

This parameter determines the maximum level to which the vessel will be allowed to fill. Should this level be reached all pumps will be switched ON, to draw the level down, as required, irrespective of the control sequence in operation.

Enter desired level in **Measurement Units (P104)**.

Peak Times

Up to ten separate Peak Tariff periods can be programmed in to the Quantum³, these periods can be set for a specific date and time or at a specific time during a period of dates or on a daily or weekly basis. The following parameters are used to set these “Peak Times”.

P400, 406, 412, 418, 424, 430, 436, 442, 448, 454 PT Day

This parameter sets the **day** on which the “Peak Time” will be in effect.

Option	Description
0 = Off (Default)	Peak Time not in effect.
1 = Every	Peak Time will be in effect everyday
2 = Monday	Peak Time will be in effect on Monday
3 = Tuesday	Peak Time will be in effect on Tuesday
4 = Wednesday	Peak Time will be in effect on Wednesday
5 = Thursday	Peak Time will be in effect on Thursday
6 = Friday	Peak Time will be in effect on Friday
7 = Saturday	Peak Time will be in effect on Saturday
8 = Sunday	Peak Time will be in effect on Sunday

P401, 407, 413, 419, 425, 431, 437, 443, 449, 455 PT Week

This parameter sets the **week** of the month in which the “Peak Time” will be in effect.

Option	Description
1 = First	Peak Time effective in first week of month
2 = Second	Peak Time effective in second week of month
3 = Third	Peak Time effective in third week of month
4 = Fourth	Peak Time effective in fourth week of month
5 = Last	Peak Time effective in last week of the month
6 = Every (Default)	Peak Time effective every week of month

P402, 408, 414, 420, 426, 432, 438, 444, 450, 456 PT Start Pk.

This parameter sets the **date** on which the “Peak Time” will **start**.

Enter the desired Start **Date** in DD:MM format.

P403, 409, 415, 421, 427, 433, 439, 445, 451, 457 PT End Pk.

This parameter sets the **date** on which the “Peak Time” will **end**.

Enter the desired End **Date** in DD:MM format.

P404, 410, 416, 422, 428, 434, 440, 446, 452, 458 PT1 Start.

This parameter sets the **time** at which the “Peak Time” will **start**.

Enter the desired Start **Time** in HH:MM format.

P405, 411, 417, 423, 429, 435, 441, 447, 453, 459 PT1 End

This parameter sets the **time** at which the “Peak Time” will **end**.

Enter the desired End **Time** in HH:MM format.

Data Log Parameters

The data log parameters contains the following information.

Totaliser Audits

P460 to P479 Total Audits

When Pump Volume is enabled, parameters **P460-P479** show the **date** and pumped **volume** total for the last **ten days**, the first on the list are the most recent and last ones are the oldest. When all ten total audits are full the oldest is pushed out and all totals increment through to allow the new days total to be registered in the first day's total audit parameter allocation.

P480 Clear Logs

This parameter enables **all** of the Total Audits (P460 – P479) to be cleared to factory default values.

Important Information

In order to ensure the accuracy of pumped Volume, during a 24-hour period, the **Time P932** must be set correctly. And if required, enable **Daylight Saving** for the appropriate time difference **P970 – P979**.

Temperature

The following parameters give information on temperature conditions seen by the **Temperature source (P852)** in °C. All of these parameters are read only and cannot be changed, though if P852 is changed they will be reset.

P580 Minimum Temperature

This parameter displays the minimum temperature recorded.

P581 Minimum Temperature Date

This parameter displays the date when the minimum temperature was recorded.

P582 Minimum Temperature Time

This parameter displays the time when the minimum temperature was recorded.

P583 Maximum Temperature

This parameter displays the maximum temperature recorded.

P584 Maximum Temperature Date

This parameter displays the date when the maximum temperature was recorded.

P585 Maximum Temperature Time

This parameter displays the time when the maximum temperature was recorded.

P586 Current Temperature

This parameter displays the current temperature.

Pump Logs

P510 Pump 1 Hours

This parameter displays the current total running hours for Pump 1. Any value from 0 - 9999 can be entered to facilitate any update to the stored total for any reason e.g. a replacement pump being fitted.

P511 Pump 1 Starts

This parameter displays the current total pump starts for Pump 1. Any value from 0 - 9999 can be entered to facilitate any update to the stored total for any reason e.g. a replacement pump being fitted.

P512 Pump 1 Starts/Hour

This parameter displays the current pump Starts/Hour for Pump 1. Any value from 0 - 9999 can be entered to facilitate any update to the stored total for any reason e.g. a replacement pump being fitted.

P513 Pump 1 Run On

This parameter displays the current number of Pump Run On, which have occurred, for Pump 1. Any value from 0 - 9999 can be entered to facilitate any update to the stored total for any reason e.g. a replacement pump being fitted.

P514 Pump 1 Draw

This parameter displays the current Draw Rate for Pump 1, which is used to calculate the pump efficiency. Any value from 0 - 9999 can be entered to facilitate any update to the stored total for any reason e.g. a replacement pump being fitted.

P515 Pump 1 Efficiency

This parameter displays the current value for Pump 1 Efficiency, which is used to calculate the pump efficiency and will update with any change to the **Pump Draw Rate (P515)**.

P516 - P521 Pump 2

These parameters contain the same information as above for Pump 2.

P522 - P527 Pump 3

These parameters contain the same information as above for Pump 3.

P528 - P533 Pump 4

These parameters contain the same information as above for Pump 4.

P534 - P539 Pump 5

These parameters contain the same information as above for Pump 5.

P540 - P545 Pump 6

These parameters contain the same information as above for Pump 6.

P546 - P551 Pump 7

These parameters contain the same information as above for Pump 7.

P552 - P557 Pump 8

These parameters contain the same information as above for Pump 8.

P558 - P563 Pump 9

These parameters contain the same information as above for Pump 9.

P564 - P569 Pump 10

These parameters contain the same information as above for Pump 10.

FlowPulse

FlowPulse is an ultrasonic non-invasive flow monitor designed for use on most industrial liquid flow applications. FlowPulse uses a novel spread spectrum analysis technique and a radical new Digital Signal Processing approach never before used in flow monitoring to give exceptional repeatability.

Up to 4 FlowPulse units can be used with Quantum³ to give control and monitoring based on real time flow.

The Quantum³ allows the connected FlowPulse units to be allocated to either pump, main outlet (all) or to just monitor the flow in a pipe.

For the purpose of totalising and outputting flow via the mA output, a single flow value must be obtained. This flow value will either be taken from a FlowPulse allocated to 'All' or from the summation of the pumps allocated to pumps.

Configuration 1

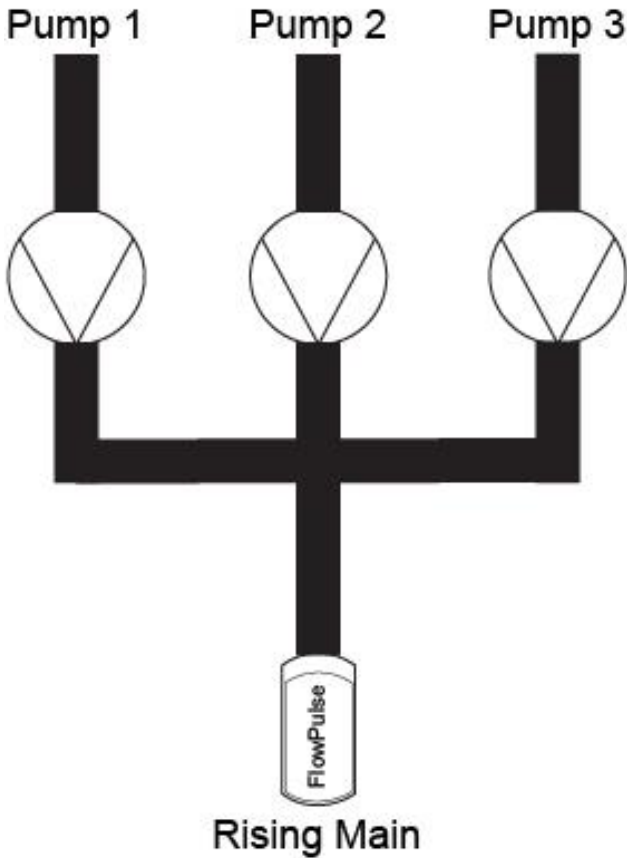

In configuration 1 the FlowPulse attached to the 'Rising Main' should be allocated as an 'All' FlowPulse (P1131, P1151, P1171, P1191). This will ensure that this FlowPulse is the only one used to totalise and output flow.

Configuration 2

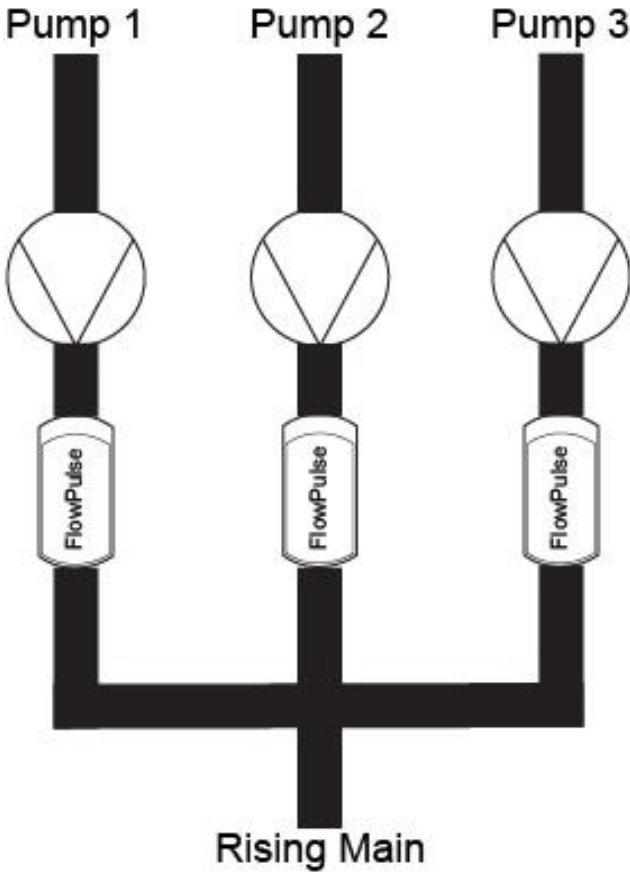

In configuration 2 each of the FlowPulse will be allocated to the pumps they are attached to. Without a FlowPulse allocated to 'All' the summation of flow being measured by all FlowPulse will be used to totalise and output flow.

Configuration 3

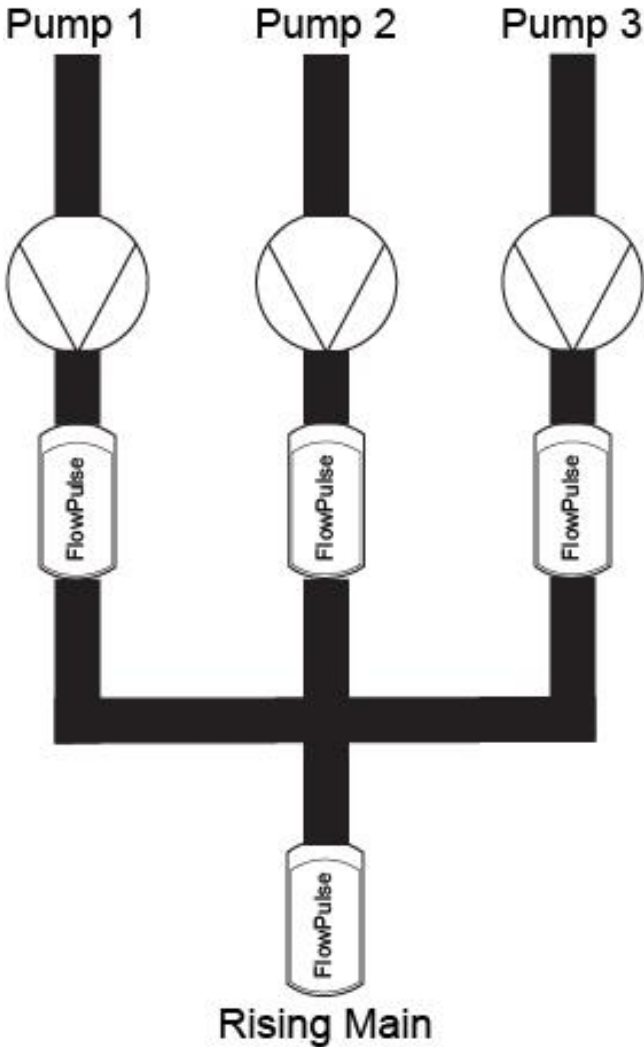

Configuration 3 has a FlowPulse allocated to each pump and a FlowPulse attached to the 'Rising Main' allocated to 'All'. In this situation although there are FlowPulse attached to the pumps, the FlowPulse attached to the 'Rising Main' and allocated to 'All' will be used as the output for flow and totalising.

If more than one FlowPulse is allocated as 'All' the lowest numbered FlowPulse will be used as the flow value for totalising and output.

Quantum³ and FlowPulse allow the user to set alarms for burst, block, storm and non-return valve failure.

FlowPulse units that are connected to the Quantum³ have their own parameters for calibrating them for the pipes they are monitoring. When returning to 'Run Mode' (after being in 'Program Mode') the parameters of all Flow Pulses are updated.

Each FlowPulse connected to the Quantum³ needs to have a unique slave address (all supplied FlowPulse are pre-set to 126), this can be changed using 'FlowPulse PC' software. This address must then be set in the Quantum³.

To set the Quantum³ so that flow being measured by each of the FlowPulses is visible on the screen, set P815 to 4 = Rate. This will cause the flow from each of the FlowPulses so scroll round on the screen.

General

The following parameters apply to all of the FlowPulses that are set up.

P1110 Volume Units

This parameter determines the volume units the flow measured by the FlowPulse is displayed as.

Option	Description
1 = Litres (Default)	Flow will be measured in litres
2 = Cubic M	Flow will be measured in Cubic Meters
3 = Cubic feet	Flow will be measured in Cubic feet
4 = UK Gallons	Flow will be measured in UK Gallons
5 = US Gallons	Flow will be measured in US Gallons
6 = Mil.USG	Flow will be measured in Mil.USG

P1111 Time Units

This parameter determines the time units the flow is measured by when displaying the flow outputted by each FlowPulse.

Option	Description
1 = Per Second (Default)	Flow will be measured in seconds
2 = Per Minute	Flow will be measured in minutes
3 = Per Hour	Flow will be measured in hours
4 = Per Day	Flow will be measured in days

P1112 Flow Decimal

This parameter determines the number of decimal places on the reading during run mode.

Minimum = 0 (No decimal places), Maximum 3 = (3 decimal Places)

Default = 1

P1113 Clear Logs?

This parameter is used to clear the daily totalisers for all of the four FlowPulses. 0 = No, 1 = Yes

FlowPulse Setup

There is the ability to set up four FlowPulse units individually via the Quantum³. These parameters are the same for each FlowPulse.

P1130, P1150, P1170, P1190

Address

These parameters are used to set the Modbus address for each of the FlowPulses so that parameters you are setting for that FlowPulse match the desired FlowPulse. Minimum = 1, Maximum = 255 **Default = 126**

Important Information

In order to set the Modbus ID on a FlowPulse please use FlowPulse PC to connect to each sensor and set this up. For more information please contact your local Pulsar distributor.

P1131, P1151, P1171, P1191

Allocation

These parameters are used to set the allocation of each FlowPulse. You have three options when allocating a FlowPulse; it can be used to monitor the flow on either an individual pump, the main outlet or just monitor a pipe with flow.

Option	Description
0 = None (Default)	The FlowPulse is not allocated to anything
1 = Relay 1	The FlowPulse is allocated to Relay 1
2 = Relay 2	The FlowPulse is allocated to Relay 2
3 = Relay 3	The FlowPulse is allocated to Relay 3
4 = Relay 4	The FlowPulse is allocated to Relay 4
5 = Relay 5	The FlowPulse is allocated to Relay 5
6 = Relay 6	The FlowPulse is allocated to Relay 6
7 = Relay 7	The FlowPulse is allocated to Relay 7
8 = Relay 8	The FlowPulse is allocated to Relay 8
9 = Relay 9	The FlowPulse is allocated to Relay 9
10 = Relay 10	The FlowPulse is allocated to Relay 10
11 = All	The FlowPulse is allocated to a Main Outlet
12 = Monitor	The FlowPulse is allocated to Monitor some flow

P1132, P1152, P1172, P1192

Diameter

These parameters are there to set the pipe diameter that each of the FlowPulse will be strapped to. Minimum 0.01m, Maximum = 9000m **Default = 0.015m**

P1133, P1153, P1173, P1193

Pipe Type

These parameters are used to set the material of the pipes that each FlowPulse is strapped to.

Option	Description
0 = Cast Iron (Default)	Pipe material is set to Cast Iron
1 = Steel	Pipe material is set to Steel
2 = Plastic	Pipe material is set to Plastic

P1134, P1154, P1174, P1194

Density

These parameters are used to set the density of the liquid passing through the pipes that each FlowPulse is allocated to.

Option	Description
0 = Very Low	The Liquid has a Very Low density
1 = Low	The Liquid has a Low density
2 = Medium	The Liquid has a Medium density
3 = High	The Liquid has a High density
4 = Very High	The Liquid has a Very High density

P1135, P1155, P1175, P1195

Damping

Damping is used to set how quickly you wish the FlowPulse to respond to changes in fluctuations in flow speed. Minimum = 10, Maximum = 40, **Default = 24**

P1137, P1157, P1177, P1197

MagThreshold

The magnitude threshold is used to select the threshold to which the FlowPulse decides that the flow it is reading is valid. Minimum = 1200, Maximum = 3000, **Default = 1600**

P1138, P1158, P1178, P1198

SR Mode

The step response allows the FlowPulse to temporarily bypass damping and track sudden, step change in flow commonly encountered during the start and end of pumping cycles.

Option	Description
0 = Off	Step Response is turned Off
1 = On (Default)	Step Response is turned On

P1139, P1159, P1179, P1199

SR Threshold

The step response threshold is the change in flow required for the normal damping to be bypassed. The range of the step response threshold is:

Min = 22, Max = 426 **Default = 60**

426 relates to the 'Flow High' value.

The higher the step response threshold, the larger the jump in flow needs to be before damping is skipped.

P1140, P1160, P1180, P1200

Track Method

This parameter sets the flow tracking method of the FlowPulse.

Magnitude forces the tracking to go to the first point in which the flow reaches 5% of the noise floor.

Gradient will force the tracking to go to the first point in which the gradient of the trace reaches zero.

By default, the tracking method is set to auto, meaning both methods are used simultaneously. The FlowPulse will decide which will give the most reliable reading.

Option	Description
0 = Auto (Default)	The track method is chosen Automatically
1 = Magnitude	The track method is set to Magnitude
1 = Gradient	The track method is set to Gradient

P1141, P1161, P1181, P1201

Totaliser 1

These are read only parameters that display the total flow measured by the FlowPulses on the current day.

P1142, P1162, P1182, P1202

Totaliser 2

These are read only parameters that display the total flow measured by the FlowPulses on the day before the current day.

P1143, P1163, P1183, P1203

Totaliser 3

These are read only parameters that display the total flow measured by the FlowPulses two days before the current day.

P1144, P1164, P1184, P1204

Totaliser 4

These are read only parameters that display the total flow measured by the FlowPulses three days before the current day.

P1145, P1165, P1185, P1205

Totaliser 5

These are read only parameters that display the total flow measured by the FlowPulses four days before the current day.

Pumped Volume

Set Up

P205 Pump Vol. Enable

This parameter determines if Pumped Volume is in use or not.

Option	Description
0 = Off (Default)	Pumped volume calculation is switched Off
1 = On	Pumped volume calculation is switched On

P206 Settle Time

This parameter determines the time allowed for the level to settle after all pumps have switched Off, in order to avoid any effects of flow back or turbulence, before calculating the Inflow Rate. This parameter is also used in the RMA Alarm function to allow the pumping rate to settle after starting the first pump.

Enter desired time in minutes. **Default = 1 minute.**

Enter desired time in minutes.

P207 Inflow Method

This parameter determines which method is used to calculate the inflow of material during a pump down cycle.

Option	Description
0 = No Inflow	Inflow during Pumping is not calculated
1 = Avg. Inflow (Default)	Average between Inflow at time pump started and Inflow after Settle Time used to calculate Inflow during pumping.

Volume

Your Quantum³ provides a variety of volume calculation features, **with 11** pre-programmed **vessel shapes**. See **Vessel Shape (P600)** for more information. For each vessel you will need to know the **dimensions (P601-603)** in **Measurement Units (P104)** which are required to calculate the **volume (P604)** which will be displayed in the selected **Volume Units (P605)**.

If your vessel shape does not correspond with any of the pre-programmed vessel shapes, then you can use the **universal calculations**. For this you will need a level/volume graph or chart provided by the vessel manufacturer or you can create one based on the dimensions of the vessel. You can enter up to 32 pairs of breakpoints, and the more you enter, the greater accuracy of the volume calculation will be.



Conversion

P600 Vessel Shape

This parameter determines which vessel shape is used when utilising “Volume Conversion”.

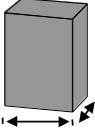
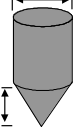
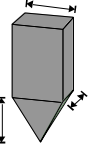
The choices are as shown in the table below, along with the **dimensions** that are required to be entered (**P601-P603**).

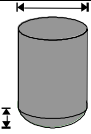
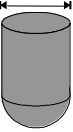
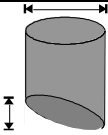
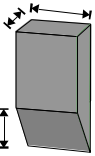
Vessel Shape	P600 Value	Dimensions
	P600=0 Cylindrical Flat base (Default)	Cylinder diameter
	P600=1=Rectangular Flat base	Width and Breadth
	P600=2 Cylindrical Cone base	Cylinder diameter and height of bottom
	P600=3 Rectangular Pyramid base	Width and Breadth of rectangular section and height of bottom

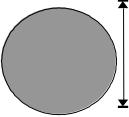
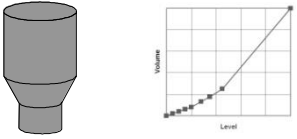
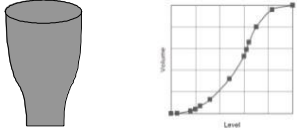
Vessel Shape	P600 Value	Dimensions
	P600=4 Cylindrical Parabola base	Cylinder diameter and height of bottom
	P600=5 Cylindrical Half-sphere base	Cylinder Diameter
	P600=6 Cylindrical Flat sloped base	Cylinder diameter and height of bottom
	P600=7 Rectangular Flat sloped base	Width and Breadth of rectangular section and height of bottom
	P600=8 Horizontal cylinder with flat ends	Cylinder diameter and tank length
	P600=9 Horizontal cylinder with parabolic ends	Cylinder diameter, length of one end section, and tank length
	P600=10 Sphere	Sphere diameter
	P600=11 Universal Linear	No dimensions required, level and volume breakpoints used.
	P600=12 Universal Curved	No dimensions required, level and volume breakpoints used.

P601-P603 Vessel Dimensions

These three parameters are used to enter the dimension required to calculate the volume. The dimensions required are as shown below and are entered **Measurements Units (P104)**.

Vessel Shape	P601	P602	P603
P600=0 Cylindrical Flat base	Cylinder Diameter		
P600=1 Rectangular Flat base		Width of rectangle	Breadth of rectangle
P600=2 Cylindrical Cone base	Height of base	Cylinder Diameter	
P600=3 Rectangular Pyramid base	Height of base	Width of rectangle	Breadth of rectangle
P600=4 Cylindrical Parabola base	Height of base	Cylinder Diameter	
P600=5 Cylindrical Half-sphere base	Cylinder Diameter		
P600=6 Cylindrical Flat sloped base	Height of base	Cylinder Diameter	
P600=7 Rectangular Flat sloped base	Height of base	Width of rectangle	Breadth of rectangle
P600=8 Horizontal cylinder flat ends	Length of Cylinder	Cylinder Diameter	
P600=9 Horiz. Cyl. parabolic ends	Length of Cylinder	Cylinder Diameter	Length of one end
P600=10 Sphere	Sphere Diameter		

P604 Calculated Volume

This parameter displays the maximum volume that has been calculated by the Quantum³ and is a Read Only parameter. The volume displayed will be shown in cubic meters and is the total volume available between **empty level (P105)** and 100% of **span (P106)**.

P605 Volume Units

This parameter determines the units that you wish to display, for volume conversion. It is used in conjunction with **P607 (maximum volume)**, and the units are shown on the display (subject to P810). The choices are:

Option	Description
0 = No Units	Volume will be totalised with no units
1 = Tons	Volume will be totalised in Tons
2 = Tonnes	Volume will be totalised in Tonnes
3 = Cubic metres (Default)	Volume will be totalised in cubic metres
4 = Litres	Volume will be totalised in litres
5 = UK Gallons	Volume will be totalised in UK Gallons
6 = US Gallons	Volume will be totalised in US Gallons
7 = Cubic feet	Volume will be totalised in cubic feet
8 = Barrels	Volume will be totalised in barrels
9 = lbs (pounds)	Volume will be totalised in lbs (pounds)

P606 Correction Factor

This parameter is used to enter a correction factor, when required, such as the specific gravity of the material so that the volume calculated is relative to the actual amount of material that can be contained between **empty level (P105)** and 100% of **span (P106)**. **Default = 1**

P607 Max Volume

This parameter displays the actual maximum volume that has been calculated by the Quantum³, i.e. **P604 Calculated Volume x P606 Correction Factor**, and is a Read Only parameter. The volume displayed will be shown in **P605 Volume Units** and is the total volume available between **empty level (P105)** and 100% of **span (P106)**.

Breakpoints

P610-P673 Level/Volume Breakpoints

These parameters are used to create a profile of the vessel when **P600=11 (universal linear)** or **P600=12 (universal curved)**. You should enter breakpoints in pairs, a reading for level and its corresponding volume. The more pairs you enter, the more accurate the profile will be. In the case of universal linear, then enter the level/volume at each of the points where the vessel changes shape. In the case of the universal curved, enter values around each arc tangent, as well as at the top and bottom.

You must enter at least two pairs, and you can enter up to 32 pairs.

Universal Linear (P600=11)

This volume calculation creates a linear approximation of the level/volume relationship, and works best if the vessel has sharp angles between each section.

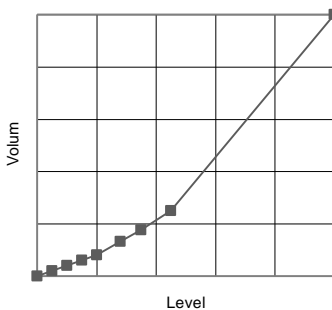
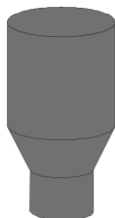

You should enter a level/volume breakpoint for each place where the vessel changes direction, and numerous where the section is slightly curved (mostly linear, but has got a small arc). You can enter any number of pairs between 2 and 32.

Universal Curved (P600=12)

This volume calculation creates a curved approximation of the level/volume relationship, and works best if the vessel is non-linear, and there are no sharp angles.

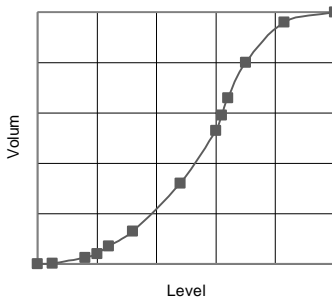
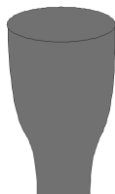

You should enter 2 level/volume breakpoints at the minimum and maximum levels, and several for each place where the vessel has got an arc. You can enter any number of pairs between 2 and 32.

Tables

P696 Reset Breakpoints

This parameter allows the resetting, to the default value, of all previously set breakpoints (P610-673), without having to access them individually. When it is necessary to reset or amend particular breakpoints this can be achieved by directly accessing the desired parameter (P610-673) and changing as required.

P697 Number of Breakpoints Set

This parameter allows you to review the number of breakpoints that have been set, without the need to access each individual one in turn, this is a “Read Only” parameter and no values can be entered.

Pump Efficiency

Set Up

P187 Pump Eff.

This parameter determines whether pump efficiency is enabled or disabled.

Option	Description
0 = Off (Default)	Pump efficiency is disabled
1 = On	Pump efficiency is enabled

P188 Calib. Delay

This parameter is used to set a delay, after all pumps have stopped, to allow for any turbulence of the material surface to settle prior to monitoring the level in the vessel and determining the inflow before the next pump cycle commences. The delay time is entered in seconds. **Default = 45 seconds.**

Important Information

When setting the **time period** for the **Calibration Delay** (P188) it is important that it does not **exceed** the **time from** when all pumps switch **Off** to the first pump **Start** during **normal operation** as it will prevent **determining** the **Inflow** and any subsequent **calculation of Efficiency**.

P189 Cal. Duration

This parameter sets the time duration over which the pumps performance will be monitored and the resulting efficiency is calculated.

Important Information

When setting the **time period** for the **Calibration Duration** (P189) it is important that it does not **exceed** the **time from** one pump **Start** to the next pump **Start** during **normal operation** as it will abort any subsequent **calculation of Efficiency**.

P190 Persist Cnt.

If an alarm is to be used to indicate when the Pump efficiency falls below a predetermined level, this parameter determines the number of consecutive times the pump will be allowed to run, at the reduced efficiency, before the alarm will be activated. The Persist Count can be set to Min. 0, Max 99.

Default = 6

P191 Demote Pumps.

When an efficiency alarm is being used this parameter will determine if a pump is to be demoted to the last pump in the duty cycle on activation of the alarm. When Demote Pump is enabled and the efficiency alarm is activated after the predetermined Persist Count (P190) the pump duty will default to a fixed duty regime with the inefficient pump being set to the last pump in the cycle which will be called to start if the level reaches the on point for that pump. A pump which has been demoted will be indicated by the relevant “pump” relay LED “flashing” RED.

Option	Description
0 = Off (Default)	Demote Pump is disabled
1 = On	Demote Pump is enabled

P192 Demote Flags

This parameter will indicate, in a binary number format as detailed below, which pumps, if any, have been demoted. Any demoted pump(s) can be reset by entering “0”.

0 = None	32 = Pump 6
1 = Pump 1	33 = Pump 1 + 6
2 = Pump 2	34 = Pump 2 + 6
3 = Pump 1 + 2	35 = Pump 1 + 2 + 6
4 = Pump 3	36 = Pump 3 + 6
5 = Pump 1 + 3	37 = Pump 1 + 3 + 6
6 = Pump 2 + 3	38 = Pump 2 + 3 + 6
7 = Pump 1 + 2 + 3	39 = Pump 1 + 2 + 3 + 6
8 = Pump 4	40 = Pump 4 + 6
9 = Pump 1 + 4	41 = Pump 1 + 4 + 6
10 = Pump 2 + 4	42 = Pump 2 + 4 + 6
11 = Pump 1 + 2 + 4	43 = Pump 1 + 2 + 4 + 6
12 = Pump 3 + 4	44 = Pump 3 + 4 + 6
13 = Pump 1 + 3 + 4	45 = Pump 1 + 3 + 4 + 6
14 = Pump 2 + 3 + 4	46 = Pump 2 + 3 + 4 + 6
15 = Pump 1 + 2 + 3 + 4	47 = Pump 1 + 2 + 3 + 4 + 6
16 = Pump 5	48 = Pump 5 + 6
17 = Pump 1 + 5	49 = Pump 1 + 5 + 6
18 = Pump 2 + 5	50 = Pump 2 + 5 + 6
19 = Pump 1 + 2 + 5	51 = Pump 1 + 2 + 5 + 6
20 = Pump 3 + 5	52 = Pump 3 + 5 + 6
21 = Pump 1 + 3 + 5	53 = Pump 1 + 3 + 5 + 6
22 = Pump 2 + 3 + 5	54 = Pump 2 + 3 + 5 + 6
23 = Pump 1 + 2 + 3 + 5	55 = Pump 1 + 2 + 3 + 5 + 6
24 = Pump 4 + 5	56 = Pump 4 + 5 + 6
25 = Pump 1 + 4 + 5	57 = Pump 1 + 4 + 5 + 6
26 = Pump 2 + 4 + 5	58 = Pump 2 + 4 + 5 + 6
27 = Pump 1 + 2 + 4 + 5	59 = Pump 1 + 2 + 4 + 5 + 6
28 = Pump 3 + 4 + 5	60 = Pump 3 + 4 + 5 + 6
29 = Pump 1 + 3 + 4 + 5	61 = Pump 1 + 3 + 4 + 5 + 6
30 = Pump 2 + 3 + 4 + 5	62 = Pump 2 + 3 + 4 + 5 + 6
31 = Pump 1 + 2 + 3 + 4 + 5	63 = Pump 1 + 2 + 3 + 4 + 5 + 6
64 = Pump 7	128 = Pump 8
256 = Pump 9	512 = Pump 10

P193 Calib. Pumps

This parameter is used to calibrate the pumps and determine the optimum (100%) efficiency of the pump from which all subsequent efficiency calculations will be derived. You can either choose to “calibrate” an individual pump or alternatively have each pump “calibrated” in turn automatically.

When selecting pumps to be calibrated individually (Option 1 to 5), it is essential that the level in the vessel is above the relevant pump start point to ensure correct calibration. Once you have selected the pump to be “calibrated” you will be prompted to return to the RUN mode, there will then be a delay before the pump starts which is equal to the **Calib. Delay (P188)** the display will show the time being counted down time to the pump start. Once the pump has started the display will show a countdown time equal to the **Cal. Duration (P189)**, calculation of pump efficiency will be completed on the expiry of the count and the unit will return to normal operation. If you choose to “calibrate” the pumps automatically (Option 7) then when the unit is returned to the RUN mode each pump will be “calibrated” in turn as and when it is next called to run.

Display Parameters

Options

P800 Display Units

This parameter determines whether the reading displayed is in **Measurement Units (P104)**, or as a **percentage of span**.

Option	Description
1 = Measured (Default)	Display is in selected units dependant on Mode (P100)
2 = Percentage	Display is in percentage of span dependent on Mode (P100).

P801 Decimal Places

This parameter determines the number of decimal places on the reading during run mode.

Minimum = 0 (No decimal places), Maximum 3 = (3 decimal Places)

P802 Display Offset

The value of this parameter is added to the reading before it is displayed, in **Measurement Units (P104)**.

It does not affect the relay setpoints or the mA output, only the reading on the display.

You could use this feature if for example you wanted to reference the reading to sea level, where you would enter the distance between **Empty Level (P105)** and sea level. If the empty level point is below sea level, then enter a negative value.

P804 Display Conversion

The reading is multiplied by the value of this parameter before being displayed. The default is 1.0, but if for example you wanted to display the reading in yards, then set the **Measurement Units (P104)** to feet, and set **P804** to 3.

Failsafe

P808 Fail-safe Mode

By default, if a fail-safe condition occurs, then the display, relays and the mA output are held at their last **known** values until a valid reading is obtained. If required, then you can change this so that the unit goes to **high** (100% of span), or **low** (empty) as follows:

Option	Description
1 = Known	Remain at the last known value
2 = High	Will fail to the high value (100% of Span).
3 = Low	Will fail to the low value (empty)

— See Also P218, P228, P238, P248, P258, P268 Relay Fail-safe and P840 mA Output Fail-safe

Important Information

In the event of a **fail-safe** condition occurring, the display, relays and mA Output can be configured to fail to a condition which is independent of each other. To set independent **Relay Failsafe** see **P218, 228, 238, 248, 258, 268**. And for independent **mA Output Failsafe** see **P840**.

P809 Fail-safe Time

In the event of a fail-safe condition occurring the fail safe timer determines the time before fail-safe mode is activated. **Default = 2 mins**.

If the timer activates, the unit goes into **fail-safe**, as determined by **P808, (Display), P218, 228, 238, 248, 258, 268, (Relays) and P840 (mA Output)**. When this happens, you will see the message “**Failed Safe!**” on the display, along with a message explaining why (lost echo or transducer fault, for example)

When a valid measurement is obtained then the display, relays and mA output will be restored and the timer is reset.

Auxiliary

P810 Units

This parameter determines whether the **Measurement units (P104)** are displayed on the auxiliary line of the display in run mode.

Option	Description
0 = No	Measurement units will not be displayed
1 = Yes (Default)	Measurement units will be displayed

P811 Alarms Messages

This parameter determines whether notification messages are displayed on the auxiliary line of the display in run mode when an alarm relay is switched on or off. The message is in the form “Alarm High ON”, where the ‘High’ is determined by the setting of the relay **Alarm ID (P212, 222, 232, 242, 252, 262)**.

Option	Description
0 = No (Default)	Alarm messages will not be displayed
1 = Yes	Alarm messages will be displayed

P812 Pumps Messages

This parameter determines whether notification messages are displayed on the auxiliary line of the display in run mode when a pump relay is switched on or off. The message is in the form “Pump 1 ON”, where the number displayed is the number of the relay.

Option	Description
0 = No (Default)	Pump messages will not be displayed
1 = Yes	Pump messages will be displayed

P813 Control Messages

This parameter determines whether notification messages are displayed on the auxiliary line of the display in run mode when a control relay is switched on or off. The message is in the form “Time ON”.

Option	Description
0 = No (Default)	Control messages will not be displayed
1 = Yes	Control messages will be displayed

P814 Miscellaneous Messages

This parameter determines whether notification messages are displayed on the auxiliary line of the display in run mode when a miscellaneous relay is switched on or off. The message is in the form “Clock ON”.

Option	Description
0 = No (Default)	Misc. messages will not be displayed
1 = Yes	Misc. messages will be displayed

P815 Auxiliary Source

When **P100 = 4 (Average)** or **5 (Differential)** the auxiliary display line can be used to display the **level** on any of the two points of measurement. When using and RMA alarm, it can also be used to display the pumping rate.

The options are as follows:

Option	Description
0 = Off (Default)	Auxiliary display not used to display levels
2 = Xducer 1	Displays level from Xducer 1
4 = Rate	Displays Inflow (I) and pumping rate (P).

P816 Totalisier (R)

This parameter determines whether or not the resettable totaliser will be displayed in the auxiliary line of the display during RUN mode. When selected, the auxiliary display will scroll between the resettable totaliser and the units selected. **Default = 0 (Off)**.

P817 Auxiliary Offset

The value of this parameter is added to the reading of the auxiliary display before it is displayed, in **Measurement Units (P104)**.

Totaliser

P820 Totaliser

Displays the current value of the, non-resettable totaliser. During run mode this totaliser can be viewed via the “Totaliser” hot key, Σ . Unlike the resettable totaliser this totaliser cannot be reset whilst in run mode, it can however be reset whilst in program mode by accessing **P820 Totaliser** and entering **zero**.

P821 Totaliser (R)

Displays the current value of the, resettable totaliser. This **totaliser** can be allocated to appear, during **run mode**, on the auxiliary display line (**P816**) or alternatively via the “Totaliser” hot key.

P822 Totaliser Decimal Places

This parameter determines the number of decimal places in the totaliser during run mode. It can be set between 1 and 3. **Default = 2**

P823 Totaliser Multiplication Factor

Use this parameter if the totaliser increments by to large or small amount, enter the factor by which the actual flow rate is multiplied by before incrementing the totaliser.

E.g. if flowrate is being calculated and displayed in ltrs/second and it is desired to increment the totaliser in cubic metres select $7 = *1000$.

When viewing, the totaliser display will state, “Units are: L*1000”, and the totaliser will be incremented every 1000 litres

Options are:

Option	Description
1= 1/1000	Totaliser will increment every 1/1000 th units of flow
2= 1/100	Totaliser will increment every 1/100 th units of flow
3= 1/10	Totaliser will increment every 1/10 th units of flow
4= 1 (Default)	Totaliser will increment every 1 units of flow
5= 10	Totaliser will increment every 10 units of flow
6= 100	Totaliser will increment every 100 units of flow
7= 1,000	Totaliser will increment every 1000 units of flow
8= 10,000	Totaliser will increment every 10,000 units of flow
9= 100,000	Totaliser will increment every 100,000 units of flow
10= 1,000,000	Totaliser will increment every 1,000,000 units of flow

mA Output 1 Parameters

Range

P830 mA Range

This parameter determines the range of the mA output, from the following.

Option	Description
0= Off	mA output disabled.
1= 0 to 20 mA	mA output directly proportional to the mA mode (P831) , so if the reading is 0% the output is 0mA. If the reading is 100% the output is 20mA.
2= 4 to 20 mA (Default)	mA output directly proportional to the mA mode (P831) , so if the reading is 0% the output is 4mA. If the reading is 100% the output is 20mA.
3= 20 to 0 mA	mA output inversely proportional to the mA mode (P831) , so if the reading is 0% the output is 20mA. If the reading is 100% the output is 0mA.
4= 20 to 4 mA	mA output inversely proportional to the mA mode (P831) , so if the reading is 0% the output is 20mA. If the reading is 100% the output is 4mA.

Operation

P831 mA Mode

This parameter determines how the mA Output relates to what is measured. By **default**, it operates exactly the same as the display (**P100**), but it can be set to operate as follows:

Option	Description
0 = Default	mA output relative to Mode (P100)
1 = Distance	mA output relative to distance .
2 = Level	mA output relative to level .
3 = Space	mA output is relative to space .
6 = Pump rate	mA output is relative to the pumping rate (for RMA)

Setpoint

By **default**, the mA Output will represent the **empty (0 or 4mA)** dependant on **(P830) mA Range** and **100%** of the operational **span (20mA)**, but you may wish to have the output represent a section of the operational span. For example, the application has an operational span of 6 metres but **output** is to **represent empty (0 or 4mA)** dependant on **(P830) mA Range** to a **level of 5 metres (20mA)**. If so P834 (Low Level) should be set to 0.00 metres and P835 (High Level) should be set to 5 metres.

P834 mA Low Value

This parameter sets, in **Measurement Units (P104)** the value of ‘level’, ‘distance’, or ‘space’, depending on the selected **mA Out Mode (P831)** at which the low mA output will occur **(0 or 4mA)** dependant on **(P830) mA Range** **Default = 0.000m**

P835 mA High Level

This parameter sets, in **Measurement Units (P104)** the value of ‘level’, ‘distance’, or ‘space’, depending on the selected **mA Out Mode (P831)** at which the high mA output will occur **(20mA)**. **Default = 6.000m**

Limits

P836 mA Low Limit

This parameter sets the lowest value that the mA output will drop to, the default is 0mA, but you can override this if the device you connect to cannot for example accept less than 2mA, yet you want to use the 0-20mA range. **Default = 0.00mA**

P837 mA High Limit

This parameter sets the highest value that the mA output will rise to, the default is 20 mA, but you can override this if the device you connect to cannot for example accept more than 18 mA, yet you want to use the 0-20 mA range. **Default = 20.00mA**

Trim

P838 mA Low Trim

If the remote device you are connected to is not calibrated, and not showing the correct **low value** (reading), then you can trim it using this parameter. You can either type in the offset directly, or use the arrow keys to move the output up and down until you get the expected result (reading) on the remote device that is connected.

P839 mA High Trim

If the remote device you are connected to is not calibrated, and not showing the correct **high value** (reading), then you can trim it using this parameter. You can either type in the offset directly, or use the arrow keys to move the output up and down until you get the expected result (reading) on the remote device that is connected.

Failsafe

P840 mA Fail-safe Mode

This parameter determines what happens to the mA output in the event of the unit going into fail-safe mode. The **default** is to do the same as the **system fail-safe (P808)**, but this can be overridden to force the mA output to an independent fail-safe mode as follows:

Option	Description
0 = Default	mA output will fail as per P808 .
1 = Hold	mA output will retain its last known value.
2 = Low	mA output will fail to its low condition.
3 = High	mA output will fail to its high condition.

mA Output 2 Parameters

mA2 Range

P890 mA2 Out Range

This parameter determines the range of the mA output, from the following.

Option	Description
0= Off	mA output disabled.
1= 0 to 20 mA	mA output directly proportional to the mA mode (P891) , so if the reading is 0% the output is 0mA. If the reading is 100% the output is 20mA.
2= 4 to 20 mA (Default)	mA output directly proportional to the mA mode (P891) , so if the reading is 0% the output is 4mA. If the reading is 100% the output is 20mA.
3= 20 to 0 mA	mA output inversely proportional to the mA mode (P891) , so if the reading is 0% the output is 20mA. If the reading is 100% the output is 0mA.
4= 20 to 4 mA	mA output inversely proportional to the mA mode (P891) , so if the reading is 0% the output is 20mA. If the reading is 100% the output is 4mA.

mA2 Operation

P891 mA2 Out Mode

This parameter determines how the mA Output relates to what is measured. By **default**, it operates exactly the same as the display (**P100**), but it can be set to operate as follows:

Option	Description
0 = Default	mA output relative to Mode (P100)
1 = Distance	mA output relative to distance .
2 = Level	mA output relative to level .
3 = Space	mA output is relative to space .
6 = Pump rate	mA output is relative to the pumping rate (for RMA)

mA2 Setpoint

By **default**, the mA Output will represent the **empty (0 or 4mA)** dependant on (**P890 mA Range**) and **100%** of the operational **span (20mA)**, but you may wish to have the output represent a section of the operational span. For example, the application has an operational span of 6 metres but **output** is to **represent empty (0 or 4mA)** dependant on (**P890 mA Range**) to a **level of 5 metres (20mA)**. If so P834 (Low Level) should be set to 0.00 metres and P835 (High Level) should be set to 5 metres.

P892 mA2 Low Level

This parameter sets, in **Measurement Units (P104)** the value of ‘level’, ‘distance’, or ‘space’, depending on the selected **mA Out Mode (P891)** at which the low mA output will occur (**0 or 4mA** dependant on (**P890 mA Range**) **Default = 0.000m**

P893 mA2 High Level

This parameter sets in **Measurement Units (P104)** the value of ‘level’, ‘distance’, or ‘space’, depending on the selected **mA Out Mode (P891)** at which the high mA output will occur (**20mA**).
Default = 6.000m

mA2 Limits

P894 mA2 Low Limit

This parameter sets the lowest value that the mA output will drop to, the default is 0mA, but you can override this if the device you connect to cannot for example accept less than 2mA, yet you want to use the 0-20mA range.
Default = 0.00mA

P895 mA2 High Limit

This parameter sets the highest value that the mA output will rise to, the default is 20 mA, but you can override this if the device you connect to cannot for example accept more than 18 mA, yet you want to use the 0-20 mA range.
Default = 20.00mA

mA2 Trim

P896 mA2 Low Trim

If the remote device you are connected to is not calibrated, and not showing the correct **low value** (reading), then you can trim it using this parameter. You can either type in the offset directly, or use the arrow keys to move the output up and down until you get the expected result (reading) on the remote device that is connected.

P897 mA2 High Trim

If the remote device you are connected to is not calibrated, and not showing the correct **high value** (reading), then you can trim it using this parameter. You can either type in the offset directly, or use the arrow keys to move the output up and down until you get the expected result (reading) on the remote device that is connected.

mA2 Failsafe

P898 mA2 Fail-safe Mode

This parameter determines what happens to the mA output in the event of the unit going into fail-safe mode. The **default** is to do the same as the **system fail-safe (P808)**, but this can be overridden to force the mA output to an independent fail-safe mode as follows:

Option	Description
0 = Default	mA output will fail as per P808 .
1 = Hold	mA output will retain its last known value.
2 = Low	mA output will fail to its low condition.
3 = High	mA output will fail to its high condition.

Compensation Parameters

Offset

P851 Measurement Offset

The value of this parameter is added to the measured distance, in **Measurement Units (P104)**.

This Offset will be added to the level, as derived from the transducer, and will affect everything including the reading on the display, the relay setpoints and the mA output.

Temperature

P852 Temperature Source

This parameter determines the source of the temperature measurement. By **default**, it is set to automatic (**P852=1**), which will automatically detect if a temperature sensor is available from the transducer. If for any reason, no temperature input is received, then the **Fixed Temp** value is used, as set by **P854**.

The temperature source can be specifically set as follows:

Option	Description
1 = Automatic	Will automatically select transducer temperature sensor, if available, or fixed temperature (P854) if no temperature sensor found.
2 = Xducer 1	Always uses temperature reading from transducer.
3 = Fixed	Always uses fixed temperature (P854)

P854 Fixed Temperature

This parameter sets the temperature, in degrees centigrade to be used if **P852 (Temperature Source) =3**. **Default = 20°C**.

OVF Persist

P865 OVF Count

This parameter determines the number of consecutive cycles that the overflow condition or the rest condition must be present for, before the OVF alarm changes state.

Velocity

P860 Sound Velocity

This parameter allows for the velocity of sound to be changed according to the atmosphere the transducer is operating in. By default, the velocity is set for sound travelling in air at an ambient temperature of 20 degrees centigrade. **Default = 342.7m/sec.**

Stability Parameters

Damping

Damping is used to damp the display, to enable it to keep up with the process but ignore minor surface fluctuations.

P870 Fill Damping

This parameter determines the **maximum rate** at which the unit will respond to an **increase in level**. It should be set slightly higher than the maximum vessel fill rate. **Default = 10m/min**

P871 Empty Damping

This parameter determines the **maximum rate** at which the unit will respond to a **decrease in level**. It should be set slightly higher than the maximum vessel empty rate. **Default = 10m/min**

Indicator

P872 Fill Indicator

This parameter determines the rate at which the LCD **fill** indicator activates. **Default = 10m/min**

P873 Empty Indicator

This parameter determines the rate at which the LCD **empty** indicator activates. **Default = 10m/min**

Rate

P874 Rate Update

This parameter determines the way in which the rate is calculated. If set to **continuous (P874=0)**, then the rate is calculated and displayed continuously, i.e. any change seen from shot to shot is calculated and displayed, but if set to use **values P874=1(Default)** then the **values** set in **P875** and **P876** are used to calculate and display the rate.

P875 Rate Time

This parameter is the period (in seconds) over which the material level rate of change is averaged before the **Rate Value (P877)** is updated. If the **Rate Distance (P876)** is exceeded before the **Rate Time (P875)** has expired, then the **Rate Value (P877)** will be updated immediately. **Default = 60sec.**

P876 Rate Distance

This parameter is the rate **Measurement Units (P104)** over which the material level must change before the **Rate Value (P877)** is updated. If the **Rate Time (P875)** expires before the **Rate Distance (P876)** is exceeded then the **Rate Value (P877)** will be updated immediately. **Default = 0.05m**

P877 Rate Value

This parameter displays the current rate of change of material level, in **Measurement Units (P104)** per minute. It is read only.

P878 Lower Cutoff

This parameter is used to select the minimum Rate to be calculated and can be used to eliminate unwanted updates from effects of ripples/waves on the surface of the material.

Filters

The following parameters can be used to filter out unwanted changes of level caused by a 'rippled' or agitated surface.

P881Fixed Distance

This parameter determines the width of gate to be used in tracking an echo and under normal circumstances will not require changing, but it can be increased in the cases where the surface is moving extremely fast (in excess of 10m/min) to ensure smooth processing of the changing level.

P882 Process Filter

This parameter determines the number of 'cycles' that will be taken before a change in level is processed and the display updated.

Option	Description
1 = Fast	level will be updated every cycle
2 = Medium	level will be updated every 8 cycles
3 = Slow (Default)	level will be updated every 16 cycles

Echo Processing Parameters

Transducer Status

P900 Transducer Status

This parameter shows the current state of the transducer. The value means the following.

Option	Description
0= OK	Transducer working correctly.
1= Disabled	Transducer is not being used (mA input is being used instead, so P101=1)
2= Stuck High	Indicates that the power and signal lines on the transducer terminals are crossed over, or the signal line is shorted to earth.
3= Not Found	No transducer is detected.

P901 Echo Confidence

This parameter displays the most recent echo confidence from the transducer. It is useful to help find the best mounting location for the transducer, where you should aim to get the highest figure. It is a percentage of confidence, that the echo reporting the level is the correct one.

P902 Echo Strength

This parameter displays the most recent echo strength figure for the transducer, where a higher figure indicates a better returned echo.

P903 Average Noise

This is the mean noise reading for the transducer. It is measured while the transducer is not firing and gives an indication of the average amount of electrical noise present on the cabling.

P904 Peak Noise

This is the peak noise reading for the transducer. It is measured while the transducer is not firing and gives an indication of the maximum amount of electrical noise present on the cabling.

P905 Sensitivity

This parameter sets the minimum DATEM level and can be increased to cover a high noise floor in noisy applications. It is recommended that this parameter not be changed unless necessary as any echo below the DATEM will be ignored. **Default 5dB (50mV).**

P906 Side Clearance

This parameter sets the distance by which the DATEM trace will be separated from the raw echo when the DATEM trace covers an echo returned from an undesired obstruction. **Default 0.05m.**

DATEM Parameters

The following two parameters are used to make changes to the DATEM trace such as setting it to its default value or using it to select a particular echo, both parameters are accessed directly by simply entering **Program Mode** then typing in the **parameter number** and pressing **ENTER**.

P020 Set DATEM

This parameter allows DATEM to be reset to its default value or alternatively allows the user to “Capture” a DATEM trace. It should be noted that when using option 1 = Capture, all echoes seen will be eliminated by DATEM.

Option	Description
0 = Quit	Exit without any change to the present DATEM trace.
1 = Capture	DATEM trace of entire visible range taken and all echo returns referenced out.
2 = Default	DATEM trace will assume its default value
3 = Def Reset	Default DATEM to factory settings.
4 = Set Min DATEM	When set, DATEM levels at this point will be accepted as a minimum.

P021 Set Distance

Allows the user or service personnel to determine which echo is to be displayed. On start-up, if the unit displays an incorrect reading then simply enter the distance from the transducer to the required level and, if an echo is present at this point, the Gate will establish itself around the chosen echo, DATEM will update in front of the Gate and reference out any other unwanted echoes.

It should be noted that DATEM will reset to default values whilst performing this function, and reform itself once it has selected an echo.

Options: Enter distance from face of transducer to the target in units of measurement (P104).

System Parameters

Passcode

P921 Enable Code

Enables the passcode (**P922**), which means the passcode must be entered to go into program mode. If **disabled** (set to **0**), then no passcode is required, and ENTER is used to enter program mode. **Default = 1 (Enabled)**

P922 Passcode

This is the passcode that must be used to enter program mode. The **default** is **1997**, but this can be changed to another value from 0 to 9999.

Backup

P925 Parameter Backup & Restore

This parameter is used to make a backup of all parameters, for example to ensure a default set is maintained within the unit. If alterations are made to the parameters that do not work as intended, then the backup set can be restored into the unit.

You can make two separate backup copies if you wish, called backup 1 and backup 2, and restore from either.

The options are:

Option	Description
1= Backup 1	Make backup to area 1 of all parameters
2= Backup 2	Make backup to area 2 of all parameters
3= Restore 1	Restore all parameters from area 1
4= Restore 2	Restore all parameters from area 2

System Information

The following three parameters do not affect how the unit performs, but details, contained in them, may be required, by Pulsar, when making technical enquiries.

P926 Software Revision

This parameter will display the current software revision. It is read only and cannot be changed. The **Software Revision** can also be checked, whilst in **RUN** Mode, by pressing the **decimal point** key.

P927 Hardware Revision

This parameter will display the current hardware revision. It is read only and cannot be changed.

P928 Serial Number

This parameter will display the serial number of the unit. It is read only and cannot be changed. The **Serial Number** can also be checked whilst in **RUN** Mode by pressing the **decimal point** key.

P929 Site Identification

This parameter allows you to give each unit an individual reference number, for identification purposes. You can set any number between 1 and 99999.

P930 Factory Defaults

This parameter resets all parameter values to the original Factory Set values that were installed when the unit was tested, before despatch to you.

To **reset** parameters, enter **1 (Yes)**, and press **ENTER**, then you will see a message “**Entr if sure**”, you should press **ENTER** again. If you press any other key at this point, the parameters will not be reset, and you will see a message confirming this.

Once you have done this, you will need to reprogram the unit, to the desired application.

Date & Time

The date and time is used to, control specific relay functions and date stamp certain events that are contained in the Data Logs. It is also used in conjunction with the system watchdog that monitors the times the unit has been started.

P931 Date

This parameter displays the **current date**, in the format as set by **P933 (Date Format)** and can be reset if required.

P932 Time

This parameter displays the **current time** and can be reset if required, in the format HH: MM (24-hour format). This is set initially at the factory for UK time.

P933 Date Format

This parameter allows you to alter the format that the date is displayed to your choice of DD: MM: YY, MM: DD: YY or YY: MM: DD. The default is DD: MM: YY.

LED Colour

Each relay has an associated LED, located on the unit's front panel, which indicates the status of the relay. By default, the LED of any relay that has been programmed but is in its "OFF" state will be illuminated 'yellow'. When "ON" **alarm** relays will cause the **LED** to illuminate **Red** and **pump, control** and **miscellaneous** relays will cause the **LED** to illuminate **green**. LED's of any relays that have not been programmed will not be illuminated. Customised settings for the colour of LED's can be achieved by using the following parameters.

P935 Off Relay Colour

This parameter selects the colour that a **programmed relay** should be when it is in its "OFF" state. The **default** is **3 = yellow**, but can be changed to 'no colour', red or green.

P936 Alarm Relay Colour

This parameter selects the colour that an **alarm** relay should be when it is in its "ON" state. The **default** is **1 = red**, but can be changed to 'no colour', green or yellow.

P937 Pump Relay Colour

This parameter selects the colour that a **pump** relay should be when it is in its “**ON**” state. The **default** is **2 = green**, but can be changed to ‘no colour’, red or yellow.

P938 Control Relay Colour

This parameter selects the colour that a **control** relay should be when it is in its “**ON**” state. The **default** is **2 = green**, but can be changed to ‘no colour’, red or yellow.

P939 Miscellaneous Relay Colour

This parameter selects the colour that a **miscellaneous** relay should be when it is in its “**ON**” state. The default is **2 = green**, but can be changed to ‘no colour’, red or yellow.

Additional Information

When a relay has been failed, due to a fail signal having been received on its associated digital input, the relay LED will **flash** on and off, between **yellow** and **red**, to indicate that the **relay** has been **failed** but not put out of service. After the **maximum attempts P300** have been made to start the device **relay** and it is put **out of service** then the relay LED will remain lit on **red** until such time that the input is reset.

Watchdog

You can check how many times the unit has been switched on and look at the date and time of the last ten starts. This can be useful if there have been power failures or if for any reason the Quantum³ restarts due to a fault condition. The Quantum³ can be backed up from a battery which automatically cuts in during power failure, battery backed up units will continue uninterrupted operation and therefore will not register a loss of mains power. If, however, the battery was to fail during a mains power interruption, a start-up would be recorded once power has been restored.

The following parameters can be accessed by directly entering the parameter number. To do this, enter the **program mode** and then **type** in the appropriate **parameter number**.

P940 Number of Starts

This parameter shows how many times the unit has been powered up.

P941-P960 Start Date & Time

Parameters **P941** and **P942** show the **date** and **time** that the unit was last started. There are **ten start dates & times** recorded which are detailed in parameters **P943 - P960**. The first on the list are the most recent, and the last ones are the oldest. These are read only and cannot be changed.

Daylight Saving Time

Important Information

In order to ensure the correct operation of Daylight Saving Time **P932 Time** should be checked, and adjusted if necessary, to ensure that it is set for the current valid time.

P970 DST Enable

When **Enabled** (set to **1**) the internal clock will be automatically adjusted to compensate for the difference between standard time and **Daylight Saving Time**. **Default = 1 (Yes)**

P971 DST Difference

This parameter sets the time difference between standard time and **Daylight Saving Time**. The time difference is entered in HH:MM. **Default = 01:00**

P972 DST Start Time

This parameter is used to set the **time** of day at which **Daylight Saving Time** will **start**, the time is entered in the format HH: MM (24-hour format). **Default = 02:00**

P973 Start Day

Use this parameter to enter the **day** of the week (**P974**) that **Daylight Saving Time** is to **start**.

Option	Description
2= Monday	DST will start on a Monday
3= Tuesday	DST will start on a Tuesday
4= Wednesday	DST will start on a Wednesday
5= Thursday	DST will start on a Thursday
6= Friday	DST will start on a Friday
7= Saturday	DST will start on a Saturday
8= Sunday (Default)	DST will start on a Sunday

P974 Start Week

This parameter will determine the **week** of the month (**P975**) in which **Daylight Saving Time** is to **start**.

Option	Description
1= Week 1	DST will start on day (P973) in the first week (P974) of the month (P975).
2= Week 2	DST will start on day (P973) in the second week (P974) of the month (P975).
3= Week 3	DST will start on day (P973) in the third week (P974) of the month (P975).
4= Week 4	DST will start on day (P973) in the fourth week (P974) of the month (P975).
5= Last (Default)	DST will start on day (P973) in the last week (P974) of the month (P975).

P975 Start Month

This parameter is used to select the **month**, in which **Daylight Saving Time** will **start**.

Option	Description
1= January	DST will start during the month of January
2= February	DST will start during the month of February
3=March (Default)	DST will start during the month of March
4= April	DST will start during the month of April
5= May	DST will start during the month of May
6= June	DST will start during the month of June
7= July	DST will start during the month of July
8= August	DST will start during the month of August
9= September	DST will start during the month of September
10= October	DST will start during the month of October
11= November	DST will start during the month of November
12= December	DST will start during the month of December

P976 DST End Time

This parameter is used to set the **time** of day at which **Daylight Saving Time** will **end**, the time is entered in the format HH: MM (24-hour format). **Default = 02:00**.

P977 End Day

Use this parameter to enter the **day** of the week (**P974**) that **Daylight Saving Time** is to **end**.

Option	Description
2= Monday	DST will end on a Monday
3= Tuesday	DST will end on a Tuesday
4= Wednesday	DST will end on a Wednesday
5= Thursday	DST will end on a Thursday
6= Friday	DST will end on a Friday
7= Saturday	DST will end on a Saturday
8= Sunday (Default)	DST will end on a Sunday

P978 End Week

This parameter will determine the **week** of the month (**P975**) in which **Daylight Saving Time** is to **end**.

Option	Description
1= Week 1	DST will end on day (P977) in the first week (P978) of the month (P979).
2= Week 2	DST will end on day (P977) in the second week (P978) of the month (P979).
3= Week 3	DST will end on day (P977) in the third week (P978) of the month (P979).
4= Week 4	DST will end on day (P977) in the fourth week (P978) of the month (P979).
5= Last (Default)	DST will end on day (P977) in the last week (P978) of the month (P979).

P979 End Month

This parameter is used to select the **month**, in which **Daylight Saving Time** will **end**.

Option	Description
1= January	DST will end during the month of January
2= February	DST will end during the month of February
3= March	DST will end during the month of March
4= April	DST will end during the month of April
5= May	DST will end during the month of May
6= June	DST will end during the month of June
7= July	DST will end during the month of July
8= August	DST will end during the month of August
9= September	DST will end during the month of September
10= October (Default)	DST will end during the month of October
11= November	DST will end during the month of November
12= December	DST will end during the month of December

Device Comm.

RS232 Set Up

P061 Comms Baud

This parameter is used to set the speed (Baud Rate) of the RS232 communications and can be changed to suit the connecting device. **Default = 19200**

RS 485 Set Up (Optional)

Please refer to the relevant communications manual for availability of parameters and details of options.

Remote Alarm

When a Modem is connected to, via the RS232 port, (Consult Pulsar or your local distributor for further details), the following parameters are used to set up the Quantum³ so that when the level reaches a specific alarm point, as determined by the setting of the relay(s) the unit will dial and connect to a remote telephone number to provide details of the event.

P144 Call Type

This parameter determines what type of connection is made via the modem.

Option	Description
0= Off (Default)	Remote alarm function is disabled
1 = Ring	This option initiates a connection to a remote modem/computer which will then allow remote communication with the unit. Please consult Pulsar or your local distributor for further details.
2= SMS	This option initiates a predetermined message which is sent to the remote telephone number detailing date and time the alarm was initiated, the site ID, alarm condition and level at the time the alarm was initiated.

P145 Tel. No.1

This parameter is used to enter the number of '0's that appear at the beginning of the telephone number to be dialled that is to receive the message.

Option	Description
0= None	No '0's present at the beginning of the telephone number to be dialled.
1 = Add 0 (Default)	1 '0' present at the beginning of the telephone number to be dialled.
2= Add 00	2 '0's present at the beginning of the telephone number to be dialled.

P146 Tel. No2

This parameter is used to enter to enter the next 6 digits, following the '0's, of the telephone number to be dialled. If there are less than 6 digits following the '0's, then just enter the digits required, if there are more digits following the '0's then enter the first 6 digits and then proceed to P147 and enter the remaining digits.

P147 Tel. No3

This parameter is used to enter any remaining digits of the telephone number to be dialled after completion of P145 and P146 above.

Example

Telephone number to be dialled is: 0 1234 123456

P985 Tel. No. 1 = 1(One '0' at the beginning of the telephone number)

P986 Tel. No. 2 = 123412 (The next 6 digits following the '0's).

P987 Tel. No. 3 = 3456 (Remaining digits of telephone number).

Test Parameters

Simulation

P980 Simulate

Test mode is used to simulate the application and confirm that all parameters and relay setpoints have been entered as expected. During simulation, there is a choice of whether the relays will change state (hard simulation) or not (soft simulation), but the LED's will always change colour as programmed, and the current output will change. If you want to test the logic of the system that the relays are connected to then select a hard simulation, but if you don't want to change the relay state, then select a soft simulation.

There are two simulation modes, **automatic** and **manual**. Automatic simulation will move the level up and down between empty level or the pre-determined **Start Level (P983)** and Pump/Control relay switch points, if you wish to change the direction of the level movement e.g. to go beyond relay setpoints, this can be done by using the arrow keys. In manual simulation, using the arrow keys will allow you to move the level up and down as required.

The choices for you to enter are as follows.

- 1= Manual soft simulation
- 2= Automatic soft simulation
- 3= Manual hard simulation
- 4= Automatic hard simulation

Whilst in Automatic hard simulation (**P980 = 4**) the switching of digital inputs can be simulated by pressing the corresponding numeric key to the input to be switched, each time the numeric key is pressed it will toggle the input between On and Off.

To return to program mode, press CANCEL and test mode will end.

Note

Pump start delay (which by default is 10 seconds) is set to 0 during simulation.

P981 Increment

By **default**, simulation mode will move by **0.1m** steps in manual simulation and by 0.1m/min in automatic simulation. Altering the increment can change this value.

P982 Rate

In automatic mode, the rate at which the level will move up and down, is determined by distance, **P981 Increment** and the time, **P982 Rate** which by **default** is set to **1min** and can be changed as required. To increase the rate at which the level moves increase the **Increment (P981)** or decrease the **Rate (P982)**. To decrease the rate at which the level moves decrease the **Increment (P981)** or increase the **Rate (P982)**.

P983 Start Level

When using automatic simulation this parameter can be used to pre-determine the point at which the simulated level will start at and return to. This can be used to simulate the lowest point to which the level would normally operate.

P984 Inc. Change

When using automatic simulation, you can incrementally increase or decrease the rate whilst running simulation. The rate is increased /decreased incrementally by the value **P984 (Incremental Change)** by using the “**decimal point**” key to **increase** and the “**plus/minus**” key to **decrease** the rate of change. **Default = 0.1m**

Hardware

P990 Self Test

If you enter 1 for this parameter, then the unit will perform a self-test. This will confirm that the various parts of the circuitry are working correctly. You will see confirmation messages that the clock and the EEPROM are working correctly, and error messages for any parts that fail.

P991 Hard Test

When this parameter is selected, the unit will test the following in turn.

- * **LED's.** Watch them change colour as shown on the display, and press, ENTER, if they operated as shown.
- * **Relays.** Press a numeric key corresponding to the number of the relay you wish to test, and the relay will change state each time the key is pressed. If you press any other key, other than a valid relay number, then the test will end.
- * **Segments.** All the segments on the LCD are lit up, so you can see if they all work. Press, ENTER, to end the test. The LED's all go green at the same time.
- * **Keys.** You should press each key, to confirm it works, with a counter showing how many more keys you have to press. Be sure to press the **CANCEL** key last, as this will show if all keys were pressed or not. If they were not, then an error message is displayed.

P992 mA Out Test

This parameter will allow you to force a specified current on the mA output, to test the equipment that it is connected to, and to make sure the unit is working correctly. The figure you enter will be generated by the mA output.

P993 mA In Test

This parameter will allow you to test the mA input, by injecting a known mA signal from an external source you can check the unit is working correctly and as expected.

P994 Transducer Test

If you enter 1 for this parameter it will continually fire the transducer, so you can check the wiring, until you press any key to cancel.

P995 Keys Test

You should press each key, to confirm it works, with a counter showing how many more keys you have to press. Press the **CANCEL** key last, as this will confirm if all keys were pressed or not. If they were not, then an error message is displayed.

Chapter 7 Troubleshooting

This section describes many common symptoms, with suggestions as to what to do.

Symptom	What to Do
Display blank, transducer not firing.	Check power supply, voltage selector switch and fuse.
Displays “No Xducer”	Check wiring to transducer.
Displays “Xducer Flt”	There is a fault with the transducer wiring, so check wiring to transducer.
Incorrect reading being displayed for current level.	Measure actual distance from transducer face to surface of material. Enter Program Mode and directly access P21 (Set Distance) type in the measured distance, press ENTER and ENTER again, when prompted, wait until SET is displayed and return to Run Mode, display will now update to the correct reading.
Material level is consistently incorrect by the same amount.	Check empty level (P105), display offset (P802) and measurement offset (P851).
LED’s change colour at relevant relay switch points but relays do not change state.	Check supply, to unit, and ensure voltage selector set to correct position.
Displays ‘Lost Comm’	Check wiring from the FlowPulse to the Quantum ³ . Also check that the Modbus ID to the FlowPulse has been setup

<p>“FPn ComErr” displayed where the rate information should be displayed for the FlowPulse in question.</p>	<p>There are two reasons for this error being displayed. The first is that there is a problem with the communications between the FlowPulse(s) in question, this will require someone to make sure the FlowPulse(s) are connected correctly. The second is that a parameter or more is not being sent to the FlowPulse correctly. This could be caused by entering a value that the FlowPulse doesn't expect, such as a pipe diameter that the specific FlowPulse cannot expect as it is too large.</p>
-------------------------------------------------------------------------------------------------------------	---------------------------------------------------------------------------------------------------------------------------------------------------------------------------------------------------------------------------------------------------------------------------------------------------------------------------------------------------------------------------------------------------------------------------------------------------------------------------------------------------------

Incorrect disposal can cause adverse effects to the environment.

Dispose of the device components and packaging material in accordance with regional environmental regulations including regulations for electrical \ electronic products.

Transducers

Remove power, disconnect the Transducer, cut off the electrical cable and dispose of cable and Transducer in accordance with regional environmental regulations for electrical \ electronic products.

Controllers

Remove power, disconnect the Controller and remove battery (if fitted).
Dispose of Controller in accordance with regional environmental regulations for electrical \ electronic products.

Dispose of batteries in accordance with regional environmental regulations for batteries.



 EU WEEE Directive Logo

This symbol indicates the requirements of Directive 2012/19/EU regarding the treatment and disposal of waste from electric and electronic equipment.

