

# MICROFLOW-i

## Technical Specifications:

MicroFlow-i is a non-contacting low power consumption microwave liquid velocity sensor. It can be installed as an individual sensor or used to provide HART communication protocol or a 4-20mA loop powered signal into a system. It's extremely low power consumption makes it the ideal velocity solution for sewerage network monitoring (CSO) and all remote installations where mains power is unavailable.



### PHYSICAL: MOUNTING OPTION SPECIFIC

<b>Sensor Body Dimensions:</b>	90 mm D x 140 mm H (3.5 in x 5.5 in)
<b>Weight:</b>	Nominal 1 kg (2.2 lb)
<b>Sensor Body Material/Description:</b>	Valox 357
<b>Transducer Cable Extensions:</b>	2-core screened
<b>Maximum Separation:</b>	Up to 1,000 m (3,280 ft)
<b>Mounting Connection:</b>	Via 1" BSP back-mounted thread or 20 mm (0.8 in) via the supplied adaptor. Optional mounting bracket available from Pulsar
<b>Mounting Angle:</b>	45° optimal and mounted at the centerline of the channel with a clear uninterrupted view

### ENVIRONMENTAL

<b>Enclosure Protection:</b>	IP68
<b>Max. &amp; Min. Temperature (Electronics):</b>	-20 °C to +60 °C (-4 °F to +140 °F)
<b>CE &amp; Radar Approvals:</b>	Listed in the Certificate of Conformity within the manual.
<b>ATEX Approval:</b>	Ex II 1 G D, Ex ia IIC T4 Ga, Ex ia IIIC T135°C Da (Directive 2014/34/EU)
<b>FM Approval:</b>	cFMus certified intrinsically safe for Class I, II, III, Division 1, Groups A, B, C, D, E, F, G

### PERFORMANCE

<b>Velocity Range:</b>	0.3 m/s to 6 m/s (0.98 ft/s to 19.7 ft/s)
<b>Operational Range:</b>	Up to 3 m H
<b>Accuracy:</b>	The greater of ±1.5% or 50 mm/s (2 in/s)
<b>Optimal Installation:</b>	Install at an angle of 45° in line with the flow. More information is provided within the manual — see the 'Locating the MicroFlow-i sensor' section
<b>Max. Channel Width per Sensor:</b>	1.5 m (4.9 ft)
<b>Radar:</b>	K-Band (ISM)
<b>Transmitter Power:</b>	<15 dBm
<b>Beam Width:</b>	20° inclusive
<b>Wake-up Time:</b>	Typically 4 seconds warm (<12 hours from last start-up)

### OUTPUTS

<b>Communication:</b>	HART compatible, 4-20mA loop powered
-----------------------	--------------------------------------

## PROGRAMMING

<b>PC Programming:</b>	MicroFlow-i HART PC
<b>Programming Security:</b>	Via passcode
<b>Programmed Data Integrity:</b>	Via non-volatile memory
<b>PC Setup &amp; Monitoring Software:</b>	Compatible with Windows 7/8/10

## SUPPLY

<b>Operating Voltage:</b>	10-28 V DC
<b>Power Consumption:</b>	<ul style="list-style-type: none"><li>Start-up = 20mA</li><li>Average current = 60 <math>\mu</math>A per hour when one velocity measurement is performed every 15 minutes</li></ul>

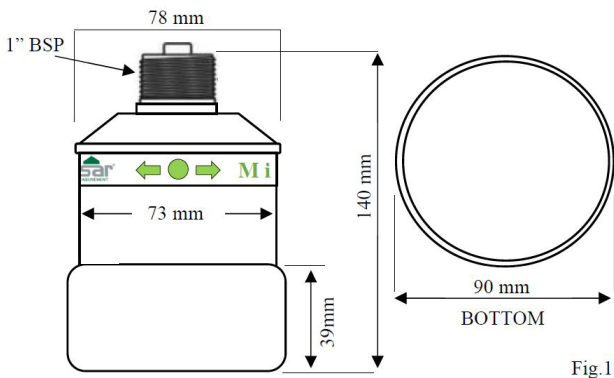

Microflow-i Drawing

Fig.1

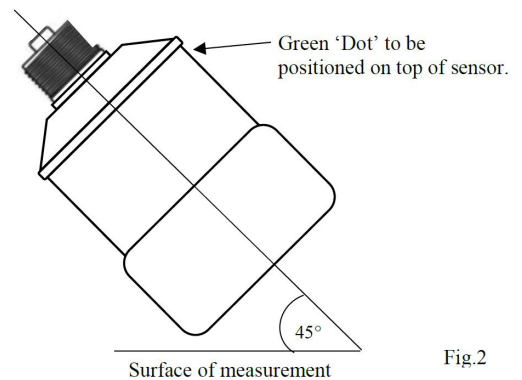

Microflow-i Mounting Drawing

Fig.2

## Delivering the Measure of Possibility

Pulsar Measurement offers worldwide professional support for all of our products, and our network of global partners all offer full support and training. Our facilities in Malvern, UK and Largo, USA are home to technical support teams who are always available to answer your call or attend your site when required. Our global presence, with direct offices in the UK, USA, Canada, and Malaysia, allows us to create close relationships with our customers and provide service, support, training, and information throughout the lifetime of your product.

For more information, please visit our website:

[www.pulsarmeasurement.com](http://www.pulsarmeasurement.com)



INFO@PULSARMEASUREMENT.COM

*Pulsar Measurement is a trading name of Pulsar Process Measurement Ltd.*

*Copyright © 2023 Pulsar Measurement  
Registered Address: 1 Chamberlain Square CS, Birmingham B3 3AX  
Registered No.: 3345604 England & Wales*

**United States**  
+1 888-473-9546

**Asia**  
+60 102 591 332

**Canada**  
+1 855-300-9151

**Oceania**  
+60 102 591 332

**United Kingdom**  
+44 (0) 1684 891371

**pulsarmeasurement.com**