

# MAGS1

# User Guide



## Arkon Flow Systems

Nováčkova 11, 614 00 Brno, Czech Republic

Tel. +420 543 214 822, Tel./Fax +420 543 215 249

Enquiries/ Orders/ General questions: [office@arkon.co.uk](mailto:office@arkon.co.uk)

Marketing support/ Brochures: [marketing@arkon.co.uk](mailto:marketing@arkon.co.uk)

Technical support: [support@arkon.co.uk](mailto:support@arkon.co.uk)

[www.arkon.co.uk](http://www.arkon.co.uk)

# List of Contents

<b>1. Introduction</b>	<b>3</b>
1.1. Operating Principle	3
1.2. Applications	3
1.3. Safety Instructions	3
1.4. Unpacking the flowmeter	3
<b>2. Installation</b>	<b>4</b>
2.1. Sensor installation	4
2.2. Dry liner	5
2.3. Electrical installation	5
2.4. Cables connections	5
2.5. Potting the sensor communication module	6
<b>3. RS485 communication</b>	<b>7</b>
<b>4. Modbus RTU</b>	<b>9</b>
4.1. Map of Modbus fields	9
4.2. Introduction	11
4.3. Definitions and Abbreviations	11
4.4. References	11
4.5. Technical data	11
4.6. General Modbus RTU	12
4.7. Commissioning	13
4.8. Modbus addressing module	13
4.9. Modbus function codes	13
4.10. Modbus holding registers	14
4.11. Password	14
4.12. Real-time measurement	15
4.13. Info	16
4.14. User settings	17
4.15. Service Settings	18
4.16. Factory Settings	19
<b>5. Internal backup</b>	<b>20</b>
5.1. Automatic saving data	20
<b>6. Self-cleaning electrodes</b>	<b>21</b>
<b>7. Liner and electrode selection</b>	<b>22</b>
<b>8. Flowmeter Dimensions</b>	<b>23</b>
<b>9. How to order your MAGS1</b>	<b>24</b>
<b>10. MAGS1 Error Code Table</b>	<b>25</b>
<b>11. Appendix</b>	<b>26</b>
11.1. CE and Conformity	26
11.2. Warranty	26
11.3. Contact	26



# 1. Introduction

## 1.1. Operating Principle

The measurement is based on the principle of Faraday's law on electromagnetic induction in which an electric voltage is induced in an electrically conductive body that moves in a magnetic field. Liquid flows through a tube in the direction of the magnetic field. Liquid with a certain minimum electrical conductivity induces a voltage which is detected by two electrodes located in a 90 degree angle from the magnetic field and the flow direction.

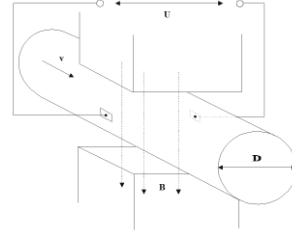



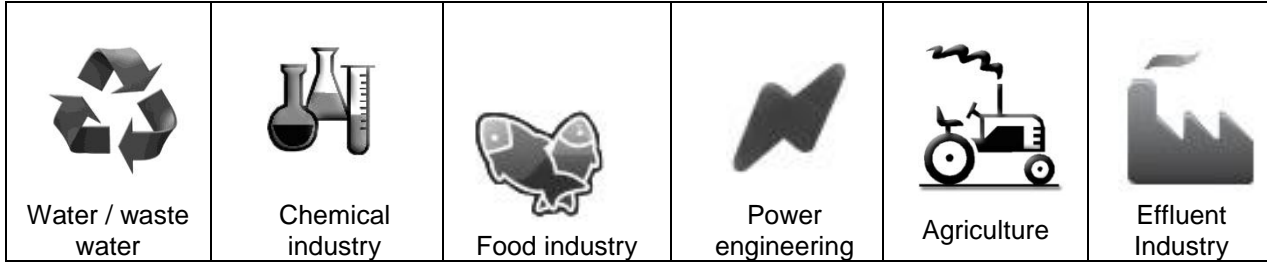

Minimum liquid conductivity	>20 $\mu\text{s} / \text{cm}$ for demineralised cold water.
	>5 $\mu\text{s} / \text{cm}$ for other liquid.
Liquid velocity	min. 0.1 m / sec, max. 10 m / sec.

## 1.2. Applications



## 1.3. Safety Instructions

-  Please read this manual carefully before using the product.
-  Keep this manual for future reference. Arkon Flow Systems, s.r.o. will not be liable for any damage caused by improper use of the product or its accessories.
-  If the device is used any different way than is specified, the electric protection may be disrupted.
-  The MAGS1 flow converter - flow-meter must not be mounted in explosive hazardous areas.

## 1.4. Unpacking the flowmeter

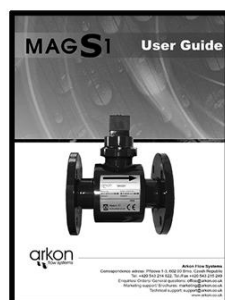

❶ While unpacking the flowmeter, conduct a visual check of the flowmeter upon receipt to make sure the product has not been damaged during transport.

❷ Check the completeness of the package. In case of any problem, contact the Arkon sales department without delay.

- MAGS1 Flowmeter
- CD-ROM + Manual

## 2. Installation

### 2.1. Sensor installation

Sensor dimensions can be found on chapter 8.

Proper sensor installation is extremely important in order for your flowmeter to work correctly. Below, you will find the minimum sensor installation requirements that need to be respected at all time.

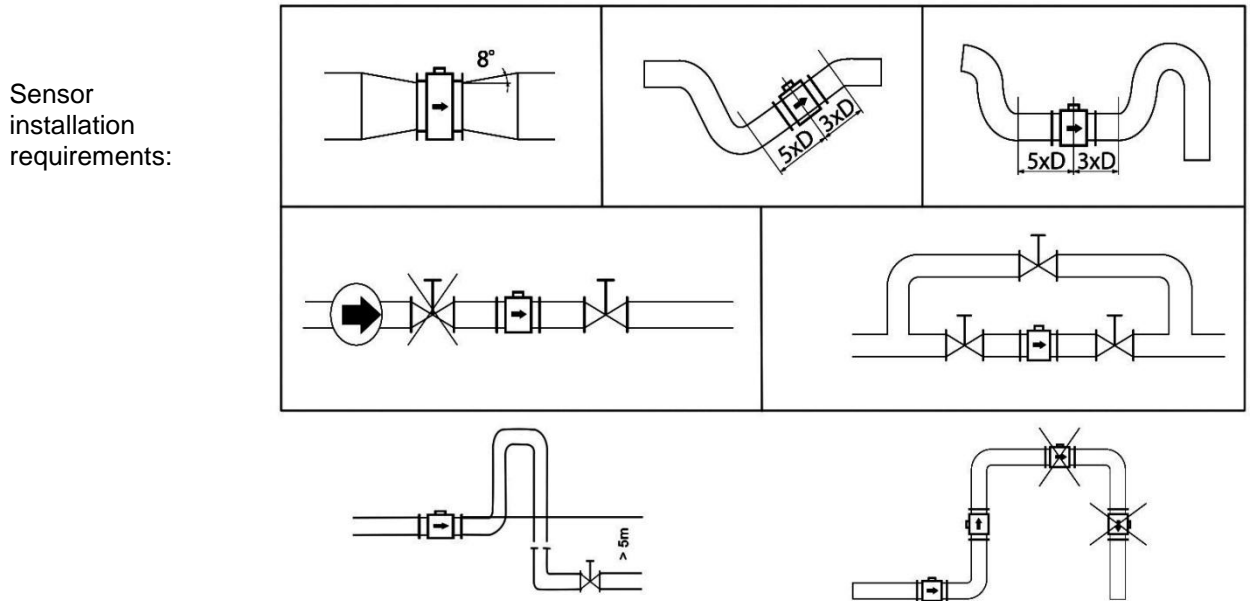

All MAGS1 sensors are supplied with 2 built in earthing electrodes that are sufficient for all applications with metal pipes and tanks. However on applications where all pipes and tanks are manufactured from plastic, it is recommended that earthing rings are also installed to ensure the maximum resistance of the sensor to earth is <1 ohm.

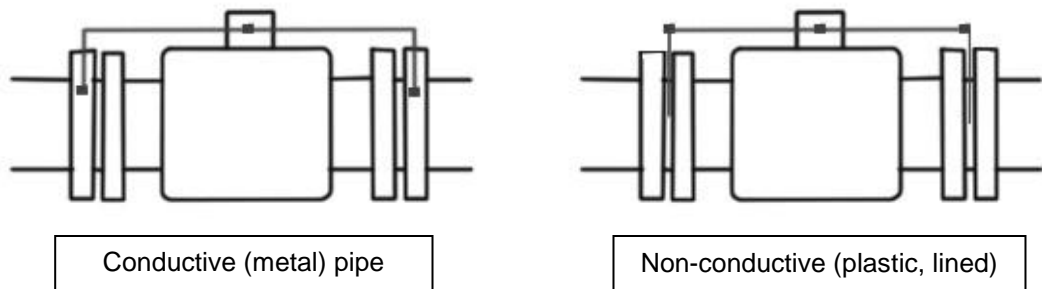

Sensor grounding with earthing rings:

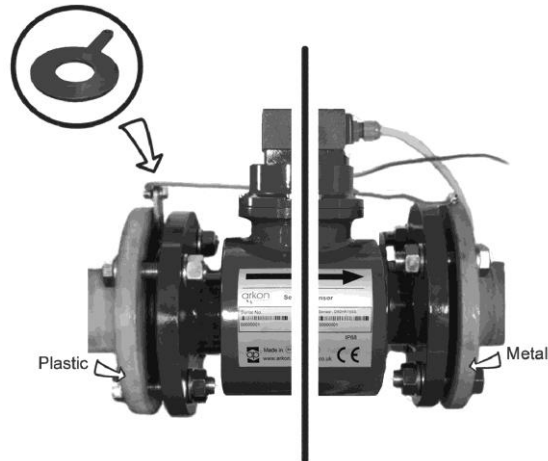

## 2.2. Dry liner

Flowmeters with a hard rubber liner can show incorrect readings during the first 2-3 days after installation, this is due to the fact that the time needed for transport and the time before installation is long enough for the liner to dry out and thus it changes shape/size, this change effects reading accuracy.

Simply by keeping the meter wet, this problem will solve itself within 2-3 days and no other action is required at all.

## 2.3. Electrical installation

Meter is produced with the cable already attached, in case of exchanging the cable pull the connection cable through the cable gland on the top of the sensor, connect it according to color coding below.



Electrical installation should only be performed by a qualified person. Standard safety regulations for hazardous electrical installations have to be respected.

## 2.4. Cables connections

The following diagram shows the connections of the cables between sensor and your RS485 bus and power supply.

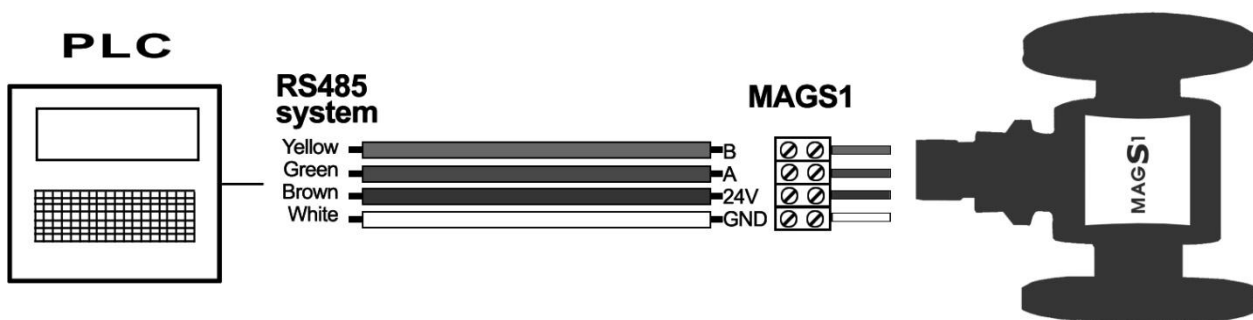

Recommended cable UNITRONIC® LiYCY (TP) 0035 830, 2x2x0.5.

## 2.5. Potting the sensor communication module

The sensor is potted already from the production; in case of exchanging the cable or any other work on sensor please follow this section.

For sensor communication module, to guarantee IP68 protection of the sensor, it is necessary to pot the sensor terminal box properly. The proper way to do this is described below:

❶	Plug the connectors into the sensor (white and green wire adjacent).
❷	Screw the small terminal box to the sensor neck (4 screws).
❸	Fill the terminal box completely with silicone, by squeezing it through the opening on top of the box.
❹	Close the small terminal box with the sealing screw.

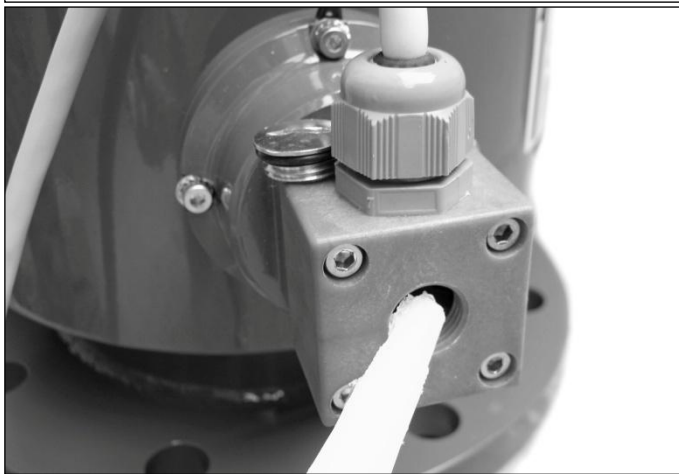
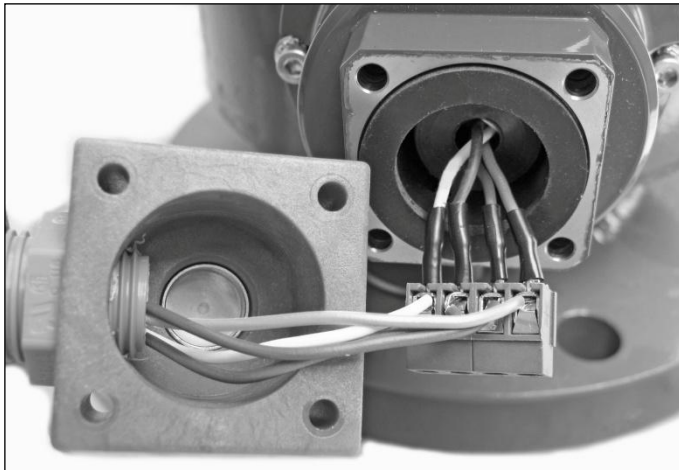

### 3. RS485 communication

The only way to set and read the flowmeter is via RS485 interface, the communication protocol is Modbus RTU over serial port, RS485 is standard for sending serial data, it uses a twisted pair of wires to send a differential signal over distances up to 1200 m without a repeater.

The differential signal makes it very robust, RS485 is one of the most popular communications methods used in industrial applications where it's noise immunity and long-distance capability are a perfect fit. RS485 is capable of multi-drop communications – up to 32 nodes.

In the following picture, the general network topology of RS485 is shown. N nodes are connected in a multipoint RS485 network, for longer lines, the termination resistances  $R_t$  are necessary on both ends of the line to eliminate reflections, use 100  $\Omega$  resistors on both ends.

The RS485 network must be designed as one line with multiple drops, not as a star.

Although total cable length maybe shorter in a star configuration, adequate termination is not possible anymore and signal quality may degrade significantly.

Electrical Specifications	
Maximum voltage	- 7 V up to + 12 V at bus terminal A or B (separately or common mode)
Baudrate	9600, 14400, 19200, 38400, 57600, 115200
Parity	no parity, Odd parity, Even parity, No parity 2 stopbits
Max distance	up to 1200m depends on cable parameters
Cabling requirements	twisted pair, plus signal ground for long distances
Multidrop	up to 32 nodes
Operating temperature	0 – 70 °C



BASIC CIRCUIT CONNECTIONS:

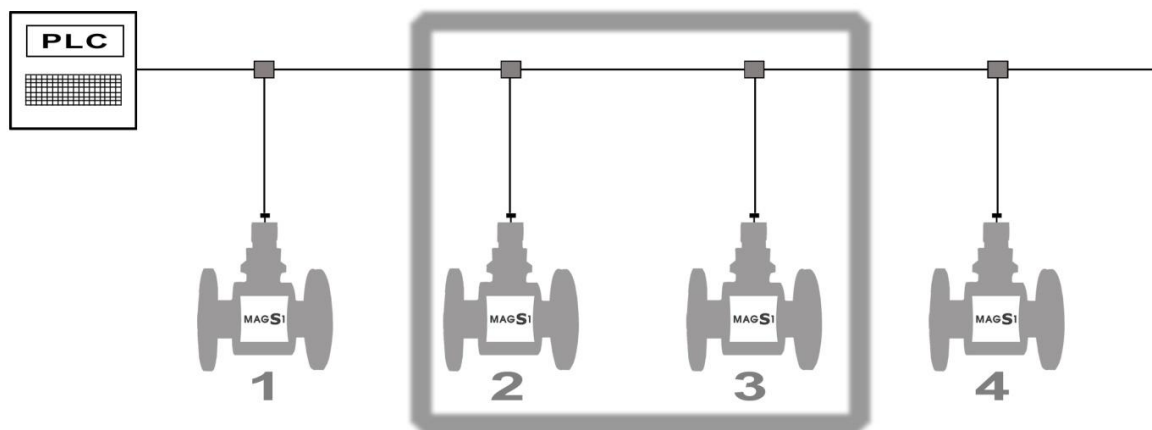

Loop View

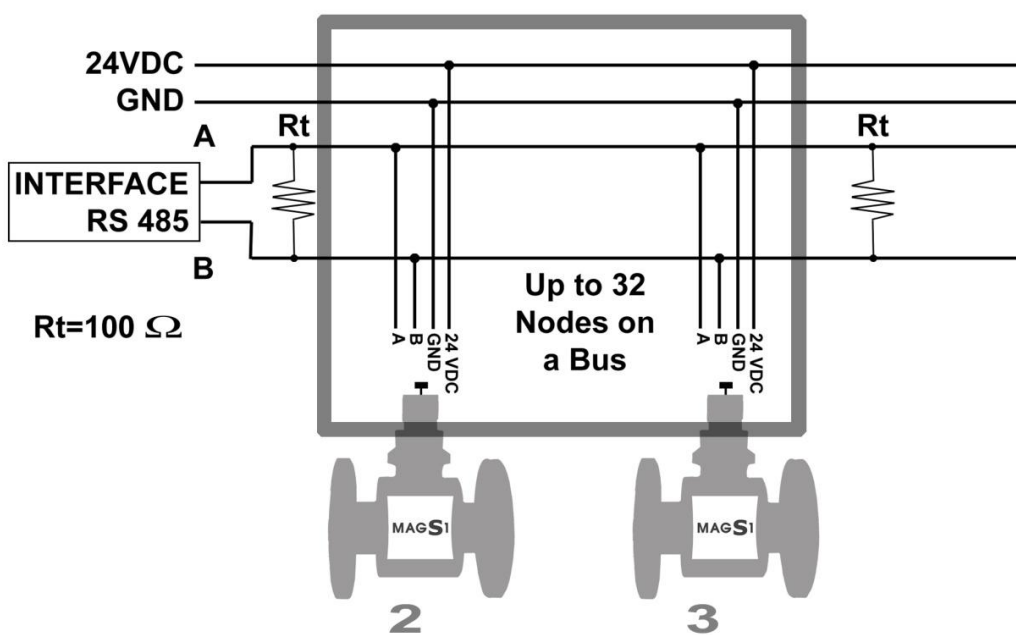

## 4. Modbus RTU

### 4.1. Map of Modbus fields

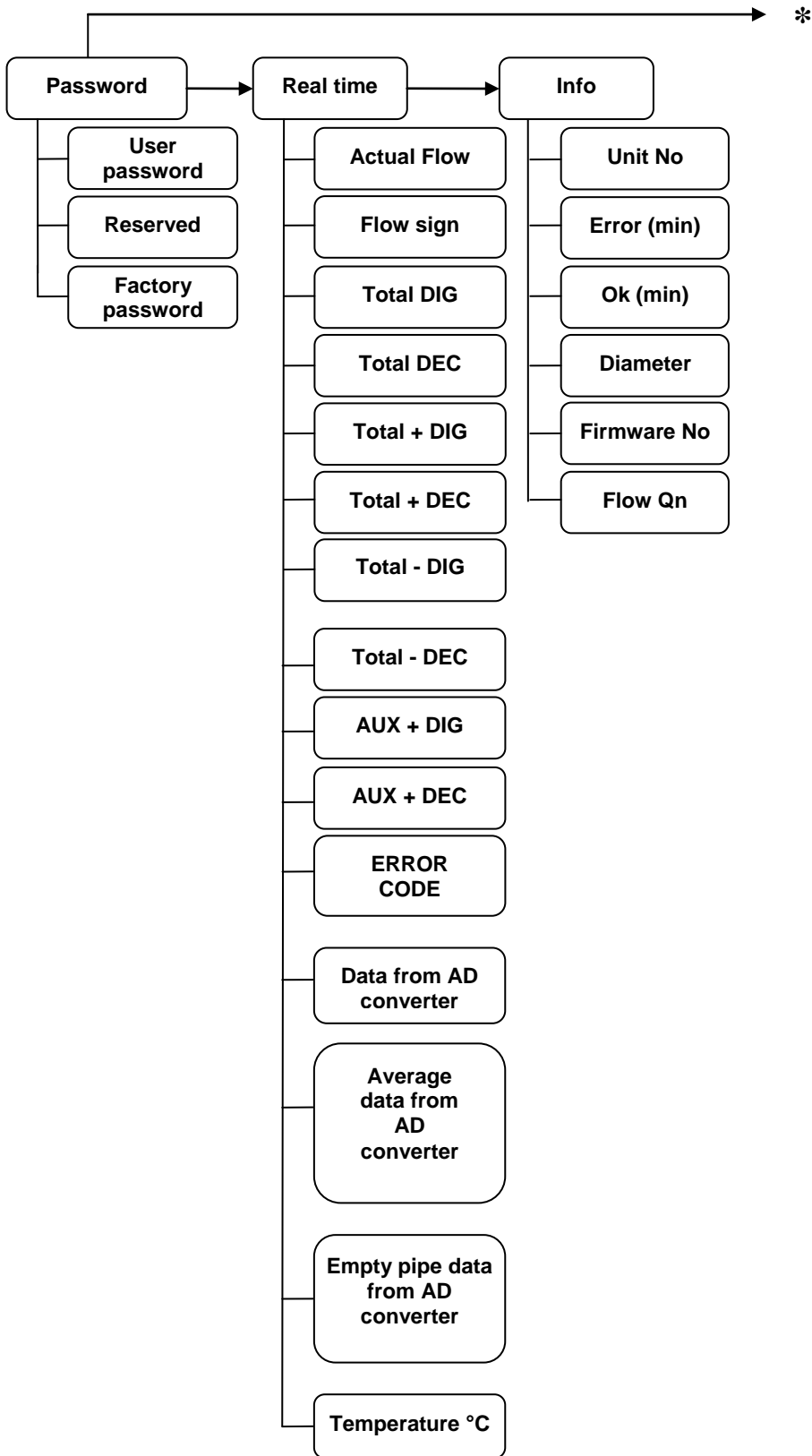

\*

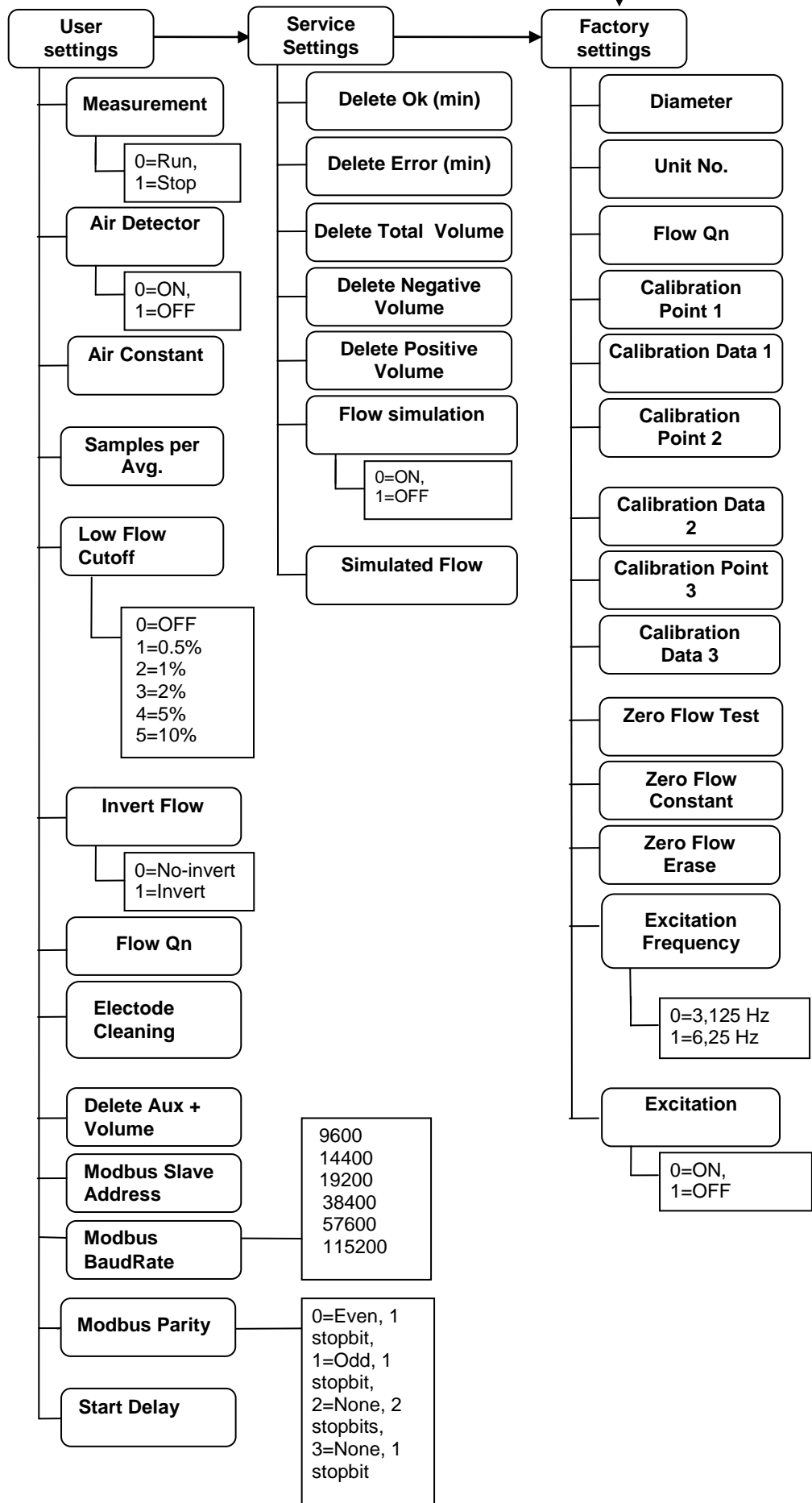

## 4.2. Introduction

This section describes the MAGS1 Modbus RTU communication protocol.

## 4.3. Definitions and Abbreviations

CRC	Cyclic Redundancy Check, Used for error-checking in Modbus RTU. See appendix
Modbus master	A Modbus device, which is able to access data in one or more connected Modbus slaves
Modbus slave	A Modbus device, which is able to respond to requests from a single Modbus master
Modbus address	Throughout this document the following notation is used to address Modbus RTU registers: 1234 - Holding register 1234 (addressed in messages by 1233)
RS485	Refers to the communication standard TIA/EIA-485 or RS-485
RTU	Remote Terminal Unit - Standard Modbus transmission mode

## 4.4. References

Reference 1	Modbus over Serial Line Specification & Implementation guide v. 1.0 modbus.org 12/02/02
Reference 2	Modbus Application Protocol Specification v. 1.1 modbus.org 12/06/02

## 4.5. Technical data

ARKON Flowmeter Modbus RTU specification	
Device type	Slave
Baud rates	9600, 14400, 19200, 38400, 57600, 115200 bits/sec.
Number of stations Recommended:	max. 31 per segment without repeaters
Device address range	1-247
Protocol	Modbus RTU (Other Modbus protocols like ASCII, Plus or TCP/IP are not supported)
Electrical interface	RS485
Supported function code	3 read holding registers 16 write multiple registers
Broadcast	No
Maximum cable length	RS485 Specification limits
Standard Modbus over serial line v1.0	
Certified	No

## 4.6. General Modbus RTU

The module complies with the Modbus serial line protocol [Reference 1].

Among other things, this implies a master-slave protocol at level 2 of the OSI model. One node, (the master), issues explicit commands to one of the „slave“-nodes and processes responses. Slave nodes will not transmit data without a request from the master node, and do not communicate with other slaves. Modbus is a mono master system, which means that only one master can be connected at any single point in time. Two modes of communication are possible, Unicast and Broadcast. Unicast mode is where the master sends a request to one slave device, and waits a specified time for a response. In Broadcast mode the master sends out a request to address „0“, which means that the information is for all slave devices on the network. In Broadcast mode there is no response from the slave devices.

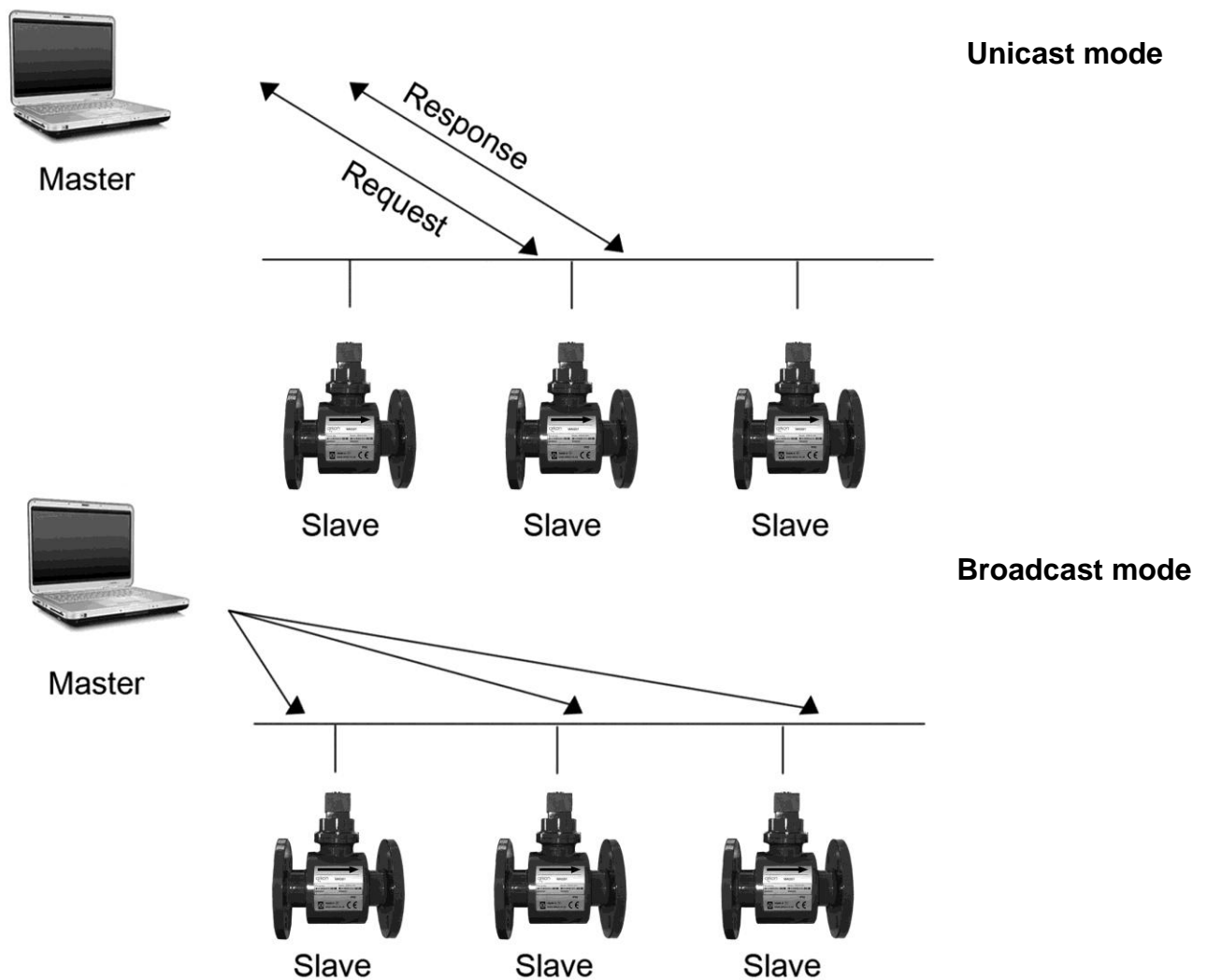

The Modbus frame is shown below, and is valid for both requests and responses.

Slave Address	Function code	Data	Crc
1 Byte	1 Byte	0-252 Bytes	2 Bytes

Further details of the Modbus RTU protocol can be found in Reference 1 and 2.

## 4.7. Commissioning

Before communicating with the master, Baud rate, node ID and update rate must be selected.

Item	Value	Comments
Slave address	1-247	Device address [Factory setting: 1]
Baud rate	9600, 14400, 19200, 38400, 57600, 115200	Communication speed [Factory setting: 9600]
Parity/framing	Even, 1 stopbit	Communication parameters [Factory setting: None, 1 stopbit]
	Odd, 1 stopbit	
	None, 2 stopbit	
	None, 1 stopbit	

## 4.8. Modbus addressing module

The module allows R/W access to the following standard Modbus data register blocks:

- Holding registers

I.e. the module will not support the other standard data register blocks:

- Coils
- „Discrete input“
- „Input registers“

## 4.9. Modbus function codes

This device supports following function codes: 3, 16 and 17.

Function code 3 and 16 are used for accessing registers. Function code 17 (report slave ID) will return a structure of identification information of the device. Below the different function code exceptions are described.

<p><b>Function code 3</b> (Read holding registers) General exceptions:</p> <ul style="list-style-type: none"> <li>• Requesting less than 1 or more than 125 registers =&gt; Exception 3 (Illegal data value)</li> <li>• Requesting more than max. message size =&gt; Exception 2 (Illegal data address)</li> <li>• Requesting data above/crossing limitation of max. register address (0xFFFF) =&gt; Exception 2 (Illegal data address)</li> <li>• If the end address is only part of a mapped holding register item (e.g. one half of a longint value) =&gt; Exception 2 (Illegal data address)</li> </ul> <p>Application exceptions:</p> <ul style="list-style-type: none"> <li>• Application errors =&gt; Exception 2 (Illegal data address)</li> </ul> <p>Holes/register alignment:</p> <ul style="list-style-type: none"> <li>• The read command always returns data if no exception is given, bad start/end alignment will result in only parts of the data item being read.</li> <li>• Holes in the holding register map return Exception 2 (Illegal data address)</li> </ul>	<p><b>Function code 16</b> (Write multiple registers) General exceptions:</p> <ul style="list-style-type: none"> <li>• Exceeding max. message size =&gt; Exception 2 (Illegal data address)</li> <li>• Writing data above/crossing limitation of max. register address (0xFFFF) =&gt; Exception 2 (Illegal data address)</li> </ul> <p>Application exceptions:</p> <ul style="list-style-type: none"> <li>• Application errors =&gt; Exception 2 (Illegal data address)</li> <li>• Application errors include writing to read only holding registers</li> </ul> <p>Holes / register alignment:</p> <ul style="list-style-type: none"> <li>• If start-address is not the start of a mapped holding register =&gt; Exception 2 (Illegal data address)</li> <li>• Writing to holes is not allowed =&gt; Exception 2 (Illegal data address)</li> <li>• If the end address is only part of a mapped holding register item (e.g. one half of a longint value), the action depends on the data type.</li> <li>• If the end address is only part of a mapped holding register item (e.g. one half of a longint value) =&gt; Exception 2 (Illegal data address)</li> </ul>
--	---

## 4.10. Modbus holding registers

In the following the holding registers for the MAGS1 Modbus RTU module are described.

Modbus Start Register	Section
2	Password
100	Real-time measurement
1000	Info
1500	Display
2000	User settings
4000	Factory settings

Holding registers memory map

When writing to the Holding registers, data validity is not checked. Writing incorrect values can result in unexpected behavior of the device. In any further explanations, the following data types are used:

- **Longint** – Number consisting of 32 bits, formed by 2 Modbus registers. It is necessary to write both Low and High Word of this item, the register number always has to be an even number. Not meeting these requirements will cause an Exception 2 error (Illegal data address). In case information about the number of decimals is available, then the final number is given by the following formula:  $Y = X * 10^{-(DEC)}$ , where Y is the final number, X the read number, and DEC the number of decimals.

- **Bool** – this item can be read, but its value has no meaning. Writing value 1 to this item will cause an unspecified operation to be performed (resetting the flow totalizers, etc.) It is necessary to write both Low and High Word of this item, the register number always has to be an even number. Not meeting these requirements will cause an Exception 2 error (Illegal data address).

Data type memory map		
Modbus register	Data Type	Low/High Word
2	Longint	L
3		H
4	Bool	L
5		H
6	Word	-

## 4.11. Password

To enter the "User settings and Factory settings" sections, it is necessary to enter a password.

Modbus register	Modbus address	No. of bytes	Data type	No. of decimal	Min Value	Max Value	Description	Read/Write
2	1	4	Longint	0	0	9 999	Password (User)	R*/W
4	3	4	Longint	0	0	9 999	Password (Service)	R*/W
6	5	4	Longint	0	0	9 999	Password (Factory)	R*/W

\*) For safety purposes, it is not possible to read this item directly. In case a 0 is read from this register, it means that no valid password was entered, and the given section is not accessible. In case a 1 is read, a valid password was entered and hence the given section can be accessed freely. To close the section, you write any possible invalid password to the password entry.

## 4.12. Real-time measurement

Modbus register	Modbus address	No. of bytes	Data type	No. of decimal	Min Value	Max Value	Description	Read/Write
100	99	4	Longint	3	0	2 <sup>32</sup>	Actual Flow	R
102	101	4	Bool	0	0	1	Flow Sign	R
104	103	4	Longint	0	0	999 999 999	Total DIG	R
106	105	4	Longint	3	0	999	Total DEC	R
108	107	4	Longint	0	0	999 999 999	Total + DIG	R
110	109	4	Longint	3	0	999	Total + DEC	R
112	111	4	Longint	0	0	999 999 999	Total – DIG	R
114	113	4	Longint	3	0	999	Total – DEC	R
116	115	4	Longint	0	0	999 999 999	Aux + DIG	R
118	117	4	Longint	3	0	999	Aux + DEC	R
120	119	4	Longint	0	0	2 <sup>16</sup>	Error Code	R
122	121	4	Longint	0	- 8 388 608	8 388 607	Data from AD converter	R
124	123	4	Longint	0	- 8 388 608	8 388 607	Average data from AD converter	R
126	125	4	Longint	0	- 8 388 608	8 388 607	Empty pipe data from AD converter	R
128	127	4	Longint	1	- 1500	2000	Temperature °C	R

### Actual Flow

Unit: m<sup>3</sup>/h - it is not possible to change it.  
Real value = Actual value / 1000.

### Flow Sign

Sign of the read flow.  
0 – positive flow  
1 – negative flow

### Total (Total +, Total -, Aux +)

Unit: m<sup>3</sup> – it is not possible to change it.  
The final number is given by the sum of the whole and the decimal.  
Example: Resulting Total measurement = (TOTAL DIG) + (TOTAL DEC\*10<sup>-3</sup>).

### Error Code

Convert read value to binary code. For more information see chapter 10.

### Data from AD converter

Raw data from AD converter. This data are averaging in average data from AD converter register.

### Average data from AD converter

Average raw data from AD converter. This data are used for flow calculating according to calibration curve.

### Empty pipe data from AD converter

Raw data from AD converter. This data are used for detection of empty pipe alarm. Threshold for detection is possible to setup in Air constant register.

### Temperature

Real value = Actual value divided by 10.  
Unit: °C – it is not possible to change it.



If value of any volume counter is higher than 999 999 999 m<sup>3</sup>, then this volume will be reset to 0.



#### 4.13. Info

Modbus register	Modbus address	No. of bytes	Data type	No. of decimal	Min Value	Max Value	Description	Read/Write
1000	999	4	Longint	0	0	39 999 999	Unit No.	R
1002	1001	4	Longint	0	0	2 <sup>32</sup>	Error (min)	R
1004	1003	4	Longint	0	0	2 <sup>32</sup>	OK (min)	R
1006	1005	4	Longint	0	0	1 000	Diameter	R
1008	1007	4	Longint	2	0	9 999	FirmWare No.	R
1010	1009	4	Longint	3	0	36 000 000	Flow Qn	R

**Unit no.** – unique number for each flowmeter. If there are any problems, please refer to this number.

**Error (min)** – the minutes count the device was not measuring because of errors.

**OK (min)** - the minutes count the device measured correctly.

**Diameter** – nominal sensor diameter that is currently configured for the given flowmeter.

**Firmware No.** – firmware version of the meter.

**Flow Qn** – expected nominal flow.

## 4.14. User settings

To enter this section, it is necessary to enter the User Password "1111".

Modbus register	Modbus address	No. of bytes	Data type	No. of decimal	Min Value	Max Value	Default	Description	Read/Write
2000	1999	4	Bool	0	0	1	1	Measurement, 0=Run, 1=Stop	R/W
2002	2001	4	Bool	0	0	1	1	Air Detector, 0=ON, 1=OFF	R/W
2004	2003	4	Longint	3	0	999	188	Air Constant	R/W
2006	2005	4	Longint	0	1	30	15	Samples per Avg.	R/W
2008	2007	4	Longint	0	0	5	3	Low Flow Cutoff, 0=OFF, 1=0.5%, 2=1%, 3=2%, 4=5%, 5=10%	R/W
2010	2009	4	Bool	0	0	1	0	Invert Flow, 0=No-invert, 1=Invert	R/W
2012	1011	4	Longint	3	0	36 000 000	3 600	Flow Qn	R/W
2014	2013	4	Bool	0	0	1	0	Electrode Cleaning	R/W
2016	2015	4	Bool	0	0	1	0	Delete Aux + Volume	R/W
2018	2017	4	Longint	0	1	247	1	Modbus Slave Address	R/W
2020	2019	4	Longint	0	0	115200	9600	Modbus BaudRate, 9600, 14400, 19200, 38400, 57600, 115200	R/W
2022	2021	4	Longint	0	0	3	3	Modbus Parity, 0=Even, 1 stopbit, 1=Odd, 1 stopbit, 2=None, 2 stopbits, 3=None, 1 stopbit	R/W
2024	2023	4	Longint	0	0	60	15	Start Delay	R/W

**Measurement – 1 = Stop** – the unit shows actual flow, but the totalizers are stopped.  
0 = Running – totalizers are active.

**Air Detector** – Empty pipe detection - if the Air detector is active and the pipe is empty, the unit automatically turns down the excitation and detect error.

**Air Constant** – constant value to determine the Empty pipe detection limit.

**Samples per Avg.** – the number of samples that the flowmeter will use for calculation of its displayed average flow value.

**Low Flow Cutoff** –the minimum flow the flowmeter will react on. Setting is done in percentage of Qn.

**Invert Flow** – possibility to change direction of the flow displayed.

**Flow Qn** - expected flow Qn.

**Electrode Cleaning** – write one for electrode cleaning.

**Delete Aux + Volume** – write value different to zero for erasing the auxiliary totalizer.

**Modbus Slave Address** – Modbus device address.

**Modbus Baudrate** – setup communication speed.

**Modbus Parity** – setup communication parameters.

**Start Delay** - time delay after device power up, measurements are not considered into totalizers.

## 4.15. Service Settings

To enter this section, it is necessary to enter the Service Password.

Modbus register	Modbus address	No. of bytes	Data type	No. of decimal	Min Value	Max Value	Description	Read/Write
3000	2999	4	Bool	0	0	1	Delete OK (min)	R/W
3002	3001	4	Bool	0	0	1	Delete Error (min)	R/W
3004	3003	4	Bool	0	0	1	Delete Total Volume	R/W
3006	3005	4	Bool	0	0	1	Delete Negative Volume	R/W
3008	3007	4	Bool	0	0	1	Delete Positive Volume	R/W
3010	3009	4	Bool	0	0	1	Flow Simulation, 0=ON, 1=OFF	R/W
3012	3011	4	Longint	3	0	36 000 000	Simulated Flow	R/W

**Delete OK (min)** – write value different to zero to erase the OK min counter.

**Delete Error (min)** – write value different to zero to erase the Error min counter.

**Delete Total Volume** – write value different to zero to erase the Total flow totalizer.

**Delete Negative Volume** – write value different to zero to erase the Total – flow totalizer.

**Delete Positive Volume** – write value different to zero to erase the Total + flow totalizer.

**Flow Simulation** – switch off/on the simulation flow function.

**Simulated Flow** – write simulated flow.

## 4.16. Factory Settings

To enter this section, it is necessary to enter the Factory Password.

Modbus register	Modbus address	No. of bytes	Data type	No. of decimal	Min Value	Max Value	Default	Description	Read/Write
4014	4013	4	Longint	0	0	1 000	-	Diameter	R/W
4016	4015	4	Longint	0	0	999999	-	Unit No.	R/W
4018	4017	4	Longint	3	0	36 000 000	-	Flow Qn	R/W
4020	4019	4	Longint	3	0	36 000 000	-	Calibration Point 1	R/W
4026	4025	4	Longint	0	-8388608	8388607	-	Calibration Data 1	R/W
4022	4021	4	Longint	3	0	36 000 000	-	Calibration Point 2	R/W
4028	4027	4	Longint	0	-8388608	8388607	-	Calibration Data 2	R/W
4024	4023	4	Longint	3	0	36 000 000	-	Calibration Point 3	R/W
4030	4029	4	Longint	0	-8388608	8388607	-	Calibration Data 3	R/W
4032	4031	4	Bool	-	0	1	0	Zero Flow Set	R/W
4036	4035	4	Longint	7	0	1000000	0	Zero Flow Constant	R/W
4034	4033	4	Bool	-	0	1	0	Zero Flow Erase	R/W
4038	4037	4	Longint	-	0	1	1	Excitation frequency, 0=3,125 Hz, 1=6,25 Hz,	R/W
4040	4039	4	Bool	-	0	1	1	Excitation, 0=ON, 1=OFF	R/W

**Diameter** – diameter of the sensor.

**Unit No.** – the serial number of unit.

**Flow Qn** –expected flow Qn. It is set automatically when you write diameter.

**Calibration Point 1** – calibration flow 1

**Calibration Point 2** – calibration flow 2

**Calibration Point 3** – calibration flow 3

**Calibration Data 1** – calibration data 1

**Calibration Data 2** – calibration data 2

**Calibration Data 3** – calibration data 3

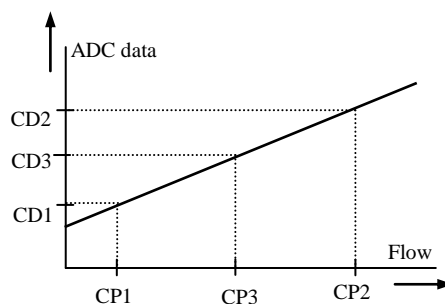

CD1 = Calibration data 1  
 CD2 = Calibration data 2  
 CD3 = Calibration data 3  
 CP1 = Calibration point 1  
 CP2 = Calibration point 2  
 CP3 = Calibration point 3  
 ADC data = data from AD converter

Note:  $CP1 < CP3 < CP2$  and  $CD1 < CD3 < CD2$ .

The calibration point 3 and the calibration data 3 could be set to zero.  $CP1 < CP2$  and  $CD1 < CD3$ .

**Zero Flow Set** – after activation this function, next 125 samples are compute to average value for zero flow constant.

**Zero Flow Constant** – Set manually value for zero flow constant.

**Zero Flow Erase** – erase zero flow constant to 0.

**Excitation Frequency** – choose the excitation frequency. For  $DN > 450$  the value must be 3,125Hz

**Excitation** – write one for turn OFF the excitation.

## 5. Internal backup

### 5.1. Automatic saving data

Once an hour following data are saved to internal EEPROM. These are:

- Total
- Total +
- Total –
- Aux +
- OK (min)
- Error (min)

If the power supply is switched off those data are recovered from the EEPROM memory. In the worst case you can lose one hour of totalizer values.

## 6. Self-cleaning electrodes

If mechanical cleaning is not possible, MAGS1 has an electrolytic method to clean electrodes.

An electrolytic method is advantageous for its simplicity; however it can only be applied for the contamination that can be removed by electrolysis. (Low contamination and deposit)







24VAC voltage is applied directly to sensor electrodes to clean them.

## 7. Liner and electrode selection



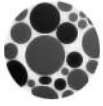

Liner and electrode material selection are an important issue when choosing your flowmeter. The tables below serve to give you an idea of general material compatibility. If you are not sure about suitability of liner/electrode material for a particular medium, please contact the Arkon sales department for further assistance, and the site where the flowmeter is to be used for what materials are acceptable for the process media. Arkon can only recommend materials, we cannot guarantee them.

Please note that Arkon offers also WRAS approved material for all standard sizes. For more info contact our sales department.

Liner Selection:

Hard Rubber	Drinking water and wastewater		 0 - 70°C
Soft Rubber	Water with abrasive particles		 0 - 70°C
PTFE	Chemicals and food industries		 0 - 130°C

Electrode selection:

Stainless Steel	General purpose, sewage, water	
Hastelloy	Seawater, Chemicals	
Titanium	Aggressive chemicals	
Platinum	Aggressive chemicals	

## 8. Flowmeter Dimensions

DIN TYPE:

DN	ØD	ØD1	CxØd	H_remote	L
25	115	85	4x14	186	200
32	140	100	4x18	205	200
40	150	110	4x18	213	200
50	165	125	4x18	227	200
65	185	145	8x18	247	200
80	200	160	8x18	266	200
100	220	180	8x18	286	250
125	250	210	8x18	312	250
150	285	240	8x22	351	300
200	340	295	12x22	421	350
250	405	355	12x26	491	400

ANSI TYPE:

DN	ØD	ØD1	CxØd	H_remote	L
1"	108	79,2	4x20	191	200
1.1/4"	117,3	88,9	4x20	201	200
1.1/2"	127	98,6	4x23	216	200
2"	152,4	120,7	8x20	227	200
2.1/2"	177,8	139,7	4x20	244	200
3"	190,5	152,4	4x20	261	200
4"	228,6	190,5	8x20	290	250
5"	254	215,9	8x23	314	250
6"	279,4	241,3	8x23	348	300
8"	342,9	298,5	8x23	422	350
10"	406,4	362	12x26	491	400

Tolerance of built-in length:  
 DN 25 – DN 150 → L ± 5 mm  
 DN 200 – DN 250 → L ± 10 mm

Standard pressure:  
 DN 25 – DN 50 → PN 40 / 150 lbs.  
 DN 65 – DN 150 → PN 16 / 150 lbs

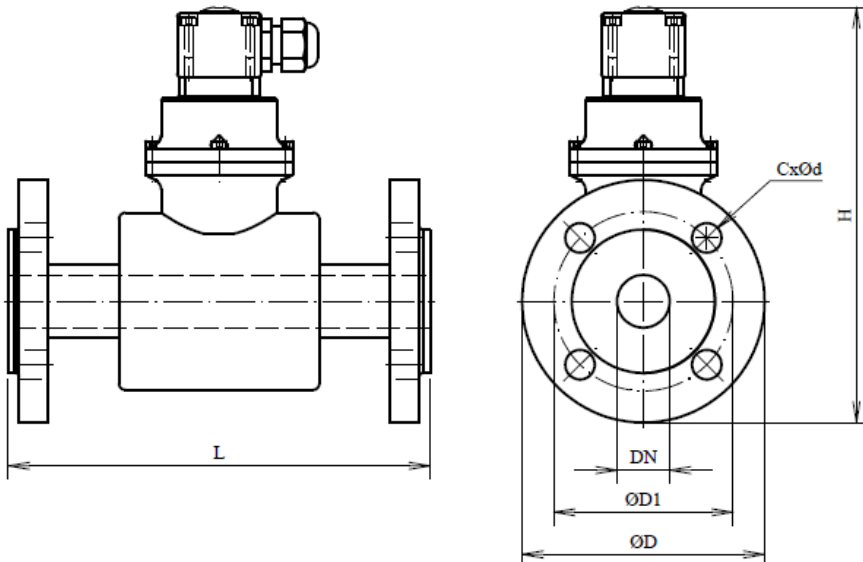



## 9. How to order your MAGS1

In case you are interested in purchasing a MAGS1 flowmeter, you can either contact the Arkon Sales Department and request a quote to serve as a basis for ordering, or you can use the Arkon price-list as an easy order form. Due to the design of the MAGS1, no single ordering code exists. Only the MAGS1 sensor has its own ordering code:

Model	Ordering code					Description
MAGS1	1	2	3	4	5	
	D					<b>Connection</b>
	A					DIN
						ANSI
		25-250				<b>Size</b>
		1 - 10				25-250 mm
						1" - 10"
			HR			<b>Liner</b>
			PT			Hard Rubber
			SR			PTFE
			NR			Soft rubber
						Hygienic rubber
				150		<b>Pressure</b>
				300		150psi
				10		300psi
				16		PN10
				25		PN16
				40		PN25
						PN40
					SS	<b>Electrodes</b>
					HA	Stainless Steel
					TA	Hastelloy C
					TI	Tantalum
					PL	Titanium
						Platinum

Example

MAGS1	D	100	HR	16	SS
-------	---	-----	----	----	----

## 10. MAGS1 Error Code Table

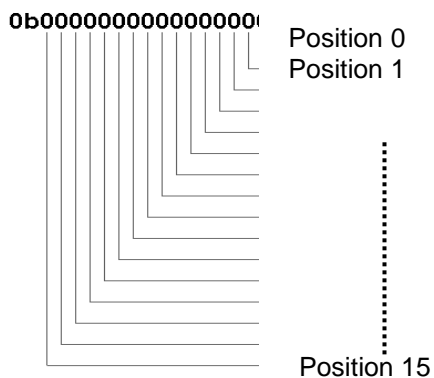

MAGS1 can detect and show a number of errors in one error code value.

Error position	Error Description
0	Empty Pipe (Air Detect)
1	Overloaded
2	Excitation
3 – 6	RESERVED (non-use)
7	AD converter error
8 – 12	RESERVED (non-use)
13	Temperature error
14-15	RESERVED (non-use)



**Errors in Modbus register are indicated in hex format and have to be converted to binary format!**

Once the error code has been converted to binary format, each position is related to a different error (see the table above). Number 1 indicates error and number 0 indicates no error.

Example:

Error shown in Modbus register:	Error position:	Read errors:
	76543210	
085HEX =	10000101 BIN	AD converter / Excitation / Empty pipe

## 11. Appendix

### 11.1. CE and Conformity

The MAGS1 Electromagnetic flowmeter is manufactured conform CE requirements.



### 11.2. Warranty

The warranty conditions are covered by Arkon Flow Systems, s.r.o. Terms & Conditions of Sale and by Arkon Flow Systems, s.r.o. Return Regulations and Warranty Conditions. The Arkon Flow Systems, s.r.o. Terms & Conditions of Sale and the Arkon Flow Systems, s.r.o. Return Regulations and Warranty Conditions are an integral part of the Resellers contract and of any Order Confirmation. Please see your Resellers contract or [www.arkon.co.uk](http://www.arkon.co.uk); Support section. The Warranty sheet is part of the Packing note of any new goods sent. For the claim or return procedure, please consult our web site [www.arkon.co.uk](http://www.arkon.co.uk) or call the Arkon Flow Systems, s.r.o. sales office.

### 11.3. Contact



Technical support: [support@arkon.co.uk](mailto:support@arkon.co.uk)  
Skype: support.arkon

Sales office: [office@arkon.co.uk](mailto:office@arkon.co.uk)

Office hours:  
8:30 – 18:00 (GMT+1)

Direct technical support:  
8:00 – 17:00 (GMT+1)