

Instruction Manual

AMF-1-Series Coriolis Mass Flow Meter



Content

Introduction.....	3
Measuring Principle.....	4
Technical Parameters	6
Module Selection	7
Structure	10
Operating Conditions: Installation.....	22
Sensor Installation.....	22
Transmitter & Sensor Connection.....	27
Energizing & Inspection	28
Maintenance	28
Settings.....	30
Function Settings.....	30
Instruction Panel	31
Operation Interface	31
Explosive Prevention	37
Principles of Anti-explosion systems.....	37
Documentation: Standard RS 485 Communication.....	38

Introduction

AMF-1-Series Coriolis Mass FlowMeters' measuring principle is based on the controlled generation of Coriolis forces. The measurement wouldnot be affected by the **pressure, temperature, viscosity, density**, etc. And the compensation calculation is not required. The structure contains twoparts: Sensor & Transmitter. The Coriolis Mass Flow Meters are designed and manufactured based on the national standard of safe explosion proof. The Explosion- proof standard is EX d ib II C T5 Gb.

The mass flow meter does not measure the volume per unit time (e.g., cubic meters per second) passing through the device; it measures the mass per unit time (e.g., kilograms per second) flowing through the device. The accuracy of the Coriolis Mass Flow Meters is $\pm 0.1\% \sim \pm 0.2\%$. The application range is large. (It could be used to measure all sorts of all sorts non-newtonian fluid, slurry, suspensions, high viscosity fluid, etc.) The requirements for the installation are low. (The straight pipe requirements in front of and behind the Coriolis Mass Flow Meters are low.) They are more reliable, stable, and the maintenance level is low.

Attention

Improperly installation and operations in dangerous occasions will come with serious consequences

Please refer to the anti-explosion part for the technical parameters about the dangerous occasions.

Measuring Principle

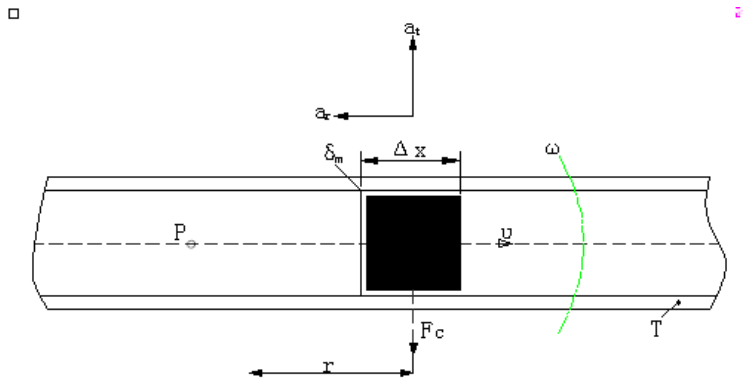

The measuring principle is based on the controlled generation of Coriolis Forces. Figure in the quality of the δm at a constant speed v of particles revolve around a fixed point P with angular velocity ω movement of the pipe, the particle will receive two acceleration components:

1. The normal acceleration a_r (centripetal acceleration), its value is equal to the $\omega^2 r$, direction toward the point P ;
2. The tangential acceleration of a_t (coriolis acceleration), its value is equal to $2\omega v$, omega direction perpendicular to a_r .

According to Newton's second law of motion (force = mass* acceleration). If it is required to produce coriolis acceleration a_r , there must be in the direction of the a_t exert a corresponding force. It is equal to $2\omega v \delta m$. And this force comes from in the pipeline. Reverse the force acting on the pipeline, $F_c = 2\omega v \delta m$ (hereinafter referred to as the coriolis force). Diagram, fluid $\delta m = \rho A \Delta x$, so the coriolis force can be represented as:

$$\Delta F_c = 2\omega v \delta m = 2\omega v \rho A \Delta x = 2\omega \delta q m \Delta x$$

Type: A is cross-sectional area for the pipe

$$\delta q m = \delta dm / dt = v \rho A$$

For a specific rotating pipe, its frequency characteristic is certain, ΔF_c only depends on the $\delta q m$, therefore, directly or indirectly measured flow in the rotating pipe of the coriolis force imposed by the fluid can be measured mass flow rate, this is the basic principle of coriolis mass flow meter.

Density measurement:

The measuring tubes are continuously excited at their resonance frequency. A change in the mass and thus the density of the oscillating system (comprising measuring tubes and fluid) results in a corresponding, automatic adjustment in the oscillation frequency. Resonance frequency is thus a function of fluid density. The microprocessor utilizes this relationship to obtain a density signal.

Attention

Power supply voltage may result in serious consequences

Please make sure to cut the power off before the installation and maintenance

Attention

Improperly installation may result in damage of the Coriolis Mass Flow Meters

Please refer to the installation and connection part of the instruction manual for detailed information

Technical Parameters & Module

Selection Technical Parameters

Applications	Suitable for Liquid, Gas, Liquid- Solid, Gas- Solid, Liquid- Gas Mass Measurement or volume measurement
Material of the Measurement Pipeline	SS 316L/ HC Hastelloy
Pressure	Please refer to the chart shown above. Special orders would be placed for high pressure.
Medium Temperature	-50°C ~+150°C; (Highest Temperature: +350°C; Lowest Temperature: -300°C could be special ordered.)
Environment Temperature	Sensor: -40°C ~+150°C; Transmitter: -20°C ~+70°C
Flow Rate Measurement Accuracy	± 0.2% 、 ± 0.1% optional
Density Measurement Accuracy	±0.002g/cm ³ 、 ±0.001g/cm ³ optional
Repeatability	±0.10% Flow Rate ±[½(Zero Point Stability/Flow Rate)×100]% Flow Rate
Output Signal	4~20mA Load Resistance <500Ω (Instantaneous or Density optional) ; 0~10kHz Instantaneous Flow Rate Pulse Signal; Standard RS 485 Communication
Explosion- Proof Symbol	EX d ib II C T5 Gb

Module Selection:**Micro Flow Meter- AMF-1-1; AMF-1-2**

Model	DN	Measurement scope (kg/h)	Work Pressure (MPa)	Connection type (mm)
AMF-1-1-AB	1.5	0~4	0~32	Weld Joints $\Phi 6 \times 1.5$
AMF-1-1-A	3	0~40	0~32	Weld Joints $\Phi 6 \times 1.5$
AMF-1-1-B	6	0~100	0~25	Weld Joints $\Phi 10 \times 2$
AMF-1-2-A	8	0~200	0~20	Weld Joints $\Phi 10 \times 1$

Medium-Small Flow Meter: AMF-1-3; AMF-1-4; AMF-1-5-A

Model	DN	Measurement scope (kg/h)	Work Pressure (MPa)	Connection Type(mm)
AMF-1-3-A	10	0~500	0~25	Weld Joints $\Phi 20 \times 4$
AMF-1-3-B	15	0~1000	0~25	Weld Joints $\Phi 20 \times 3$
AMF-1-4	20	0~3000	0~25	Weld Joints $\Phi 20 \times 2$
AMF-1-5-A	25	0~10000	0~25	Weld Joints $\Phi 31 \times 3$

Large-scale Flow Meter:AMF-1-3; AMF-1-4; AMF-1-5; AMF-1-6

High pressure could be special ordered. (4~70MPa)

Model	DN	Measurement scope (t/h)	Work Pressure (MPa)	Connection Type(mm)
AMF-1-3-A	10	0-0.5	0~4	Flange 10
AMF-1-3-B	15	0-1.0	0~4	Flange 15
AMF-1-4	20	0-3.0	0~4	Flange 20
AMF-1-5-A	25	0-10	0~1.6	Flange 25
AMF-1-5-B	40	0-20	0~1.6	Flange 40
AMF-1-6-A	50	0-30	0~1.6	Flange 50
AMF-1-6-AB	65	0-50	0~1.6	Flange 65
AMF-1-6-B	80	0-100	0~1.6	Flange 80
AMF-1-6-C	100	0-150	0~1.6	Flange 100
AMF-1-6-CD	125	0-200	0~1.6	Flange 125
AMF-1-6-D	150	0-300	0~1.6	Flange 150
AMF-1-6-E	200	0-500	0~1.6	Flange 150

Structure:

Structure of the Sensor & Hole Opening Draft

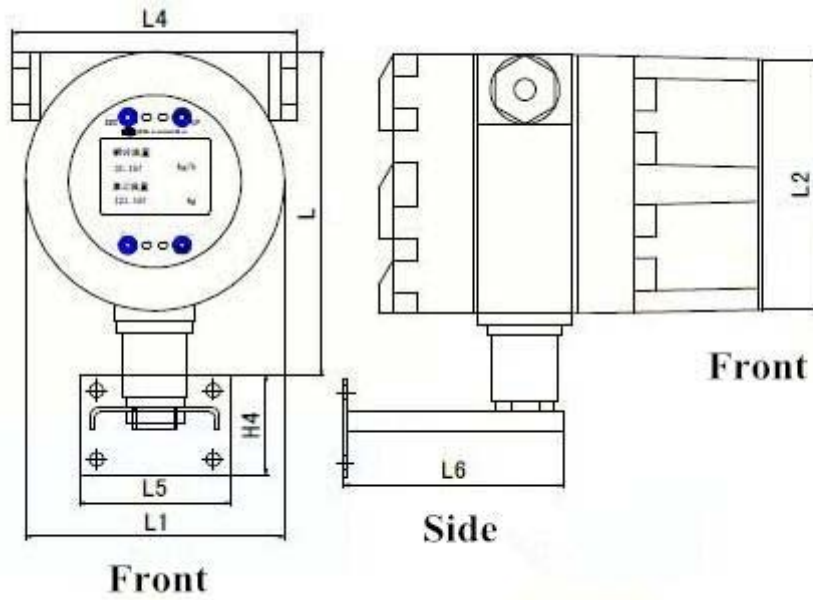

	L	L1	L2	L4	L5	L6	H4
Transmitter	156	125	118	130	70	102	46
Hole Opening		120	91	54	32	27	Φ6.5

Dimensions of Coriolis Mass Flow Meters with tiny flow rate- AMF-1-1-AB、AMF-1-1-A、AMF-1-1-B、AMF-1-1-2A

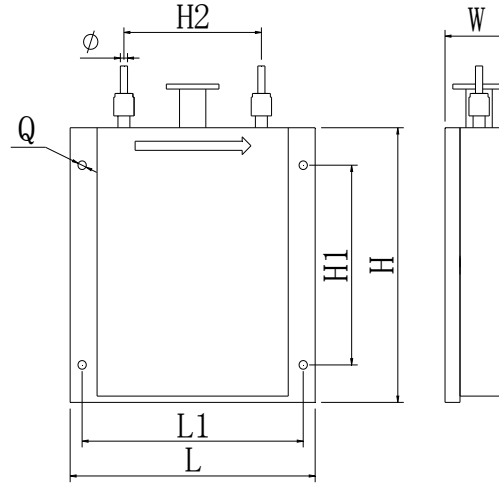

Module	ConnectionΦ	L	L1	H	H1	H2	W	Q(Diameter)
AMF-1-1AB	6	205	185	220	160	115	52.5	7
AMF-1-1A	6	205	185	220	160	115	52.5	7
AMF-1-1B	10	205	185	220	160	115	52.5	7
AMF-1-2A	10	208	188	245	185	117	58.5	7

Unit: mm

Dimensions of Coriolis Mass Flow Meters

AMF-1-3-A、AMF-1-3-B、AMF-1-4、AMF-1-5-B

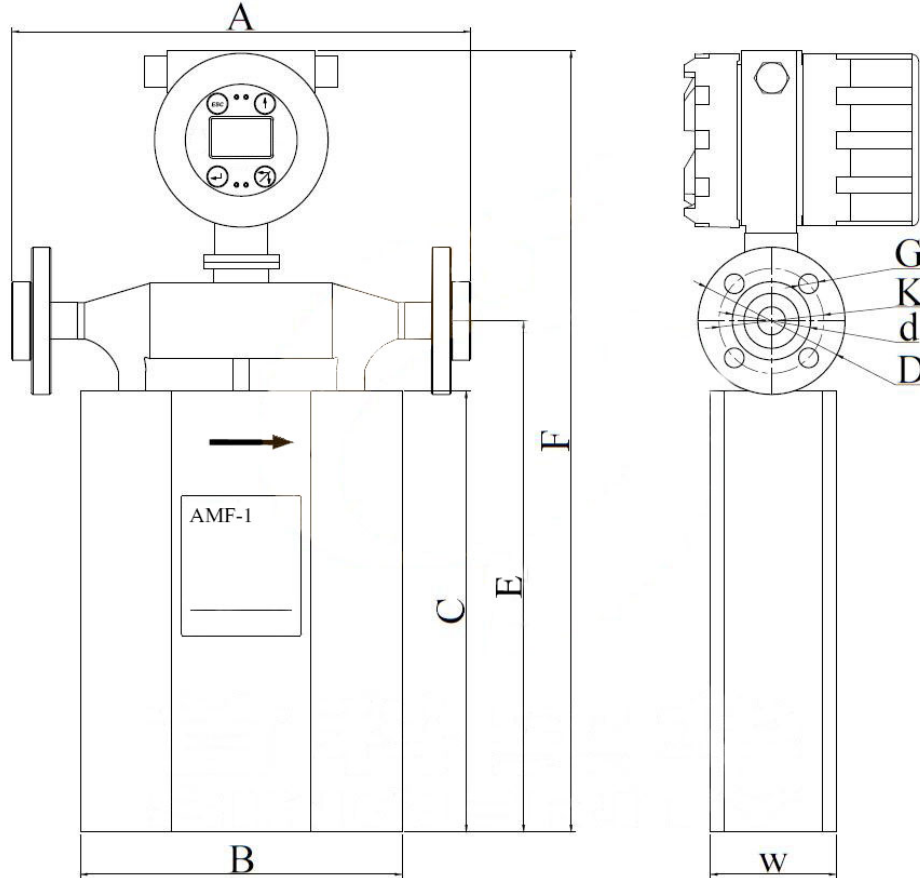

Module	Welded Flange (GB/T9112-912 4-2000)		A	B	C	E	F	W	G	K	d	D
	DN	MPa										
AMF-1-3-A	10	4.0	280	210	235	285	485	80	14	60	41	90
AMF-1-3-B	15	4.0	280	210	275	325	525	80	14	65	46	95
AMF-1-4	20	4.0	290	230	325	375	575	90	14	75	56	105

AMF-1-5-B	40	4.0	520	360	480	585	790	130	18	110	84	150
-----------	----	-----	-----	-----	-----	-----	-----	-----	----	-----	----	-----

Unit: mm

Dimensions of Coriolis Mass Flow Meters

AMF-1-5-A、AMF-1-6-A

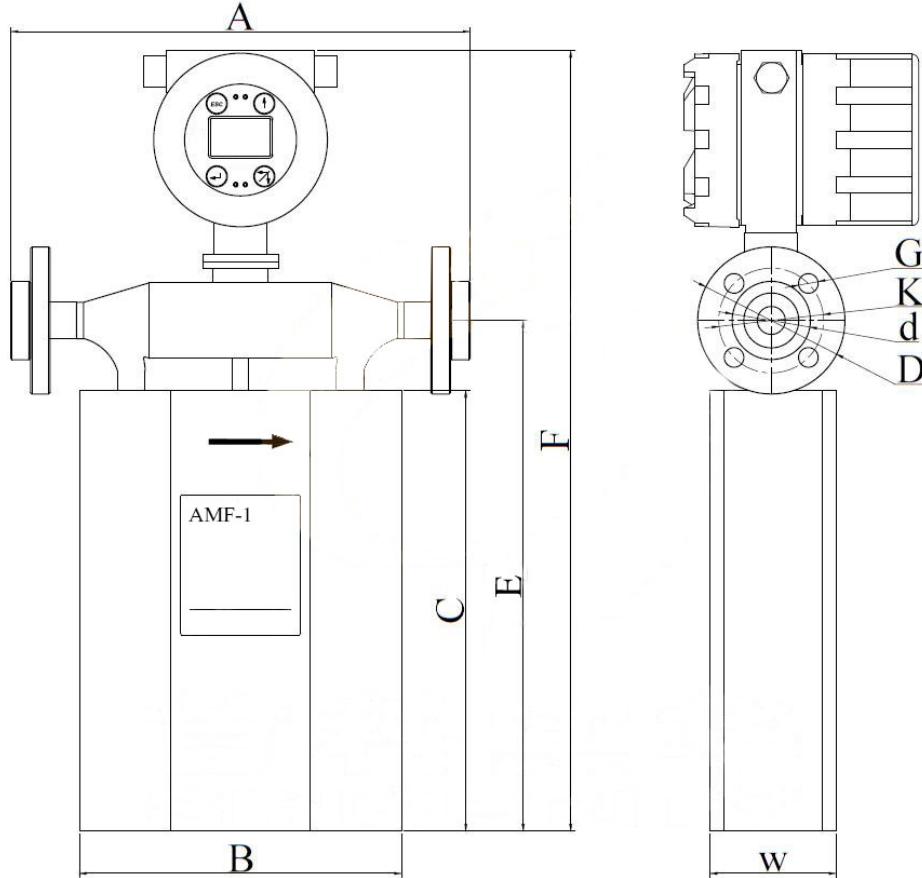

Module	Jap Joint Flange (GB/T9112-912 4-2000)		A	B	C	E	F	W	G	K	d	D
	DN	MPa										
AMF-1-5-A	25	4.0	410	300	440	500	696	120	14	85	65	115
AMF-1-6-A	50	4.0	550	370	548	670	875	153	18	125	99	165

Unit: mm

AMF-1-6-B

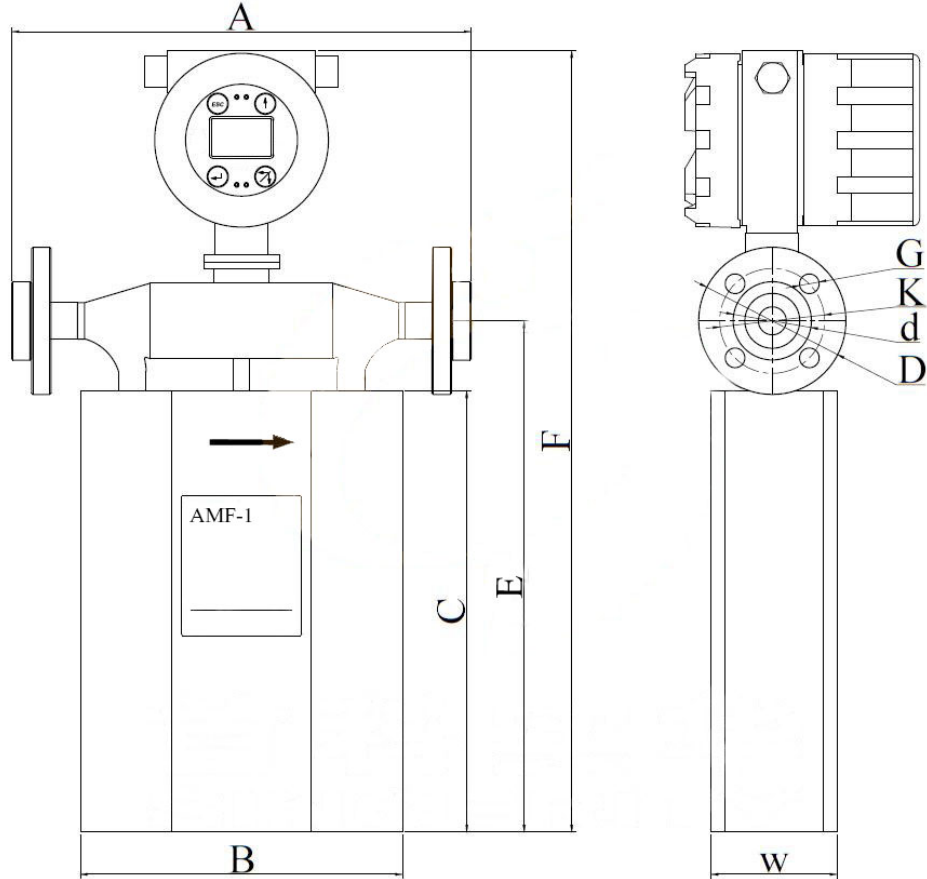

Module	Jap Joint Flange (GB/T9112-912 4-2000)		A	B	C	E	F	W	G	K	d	D
	DN	MPa										
AMF-1-6-B	80	2.5	660	470	650	767	988	220	18	160	132	200

Unit: mm

AMF-1-6-AB, AMF-1-6-C, AMF-1-6-CD, AMF-1-6-D

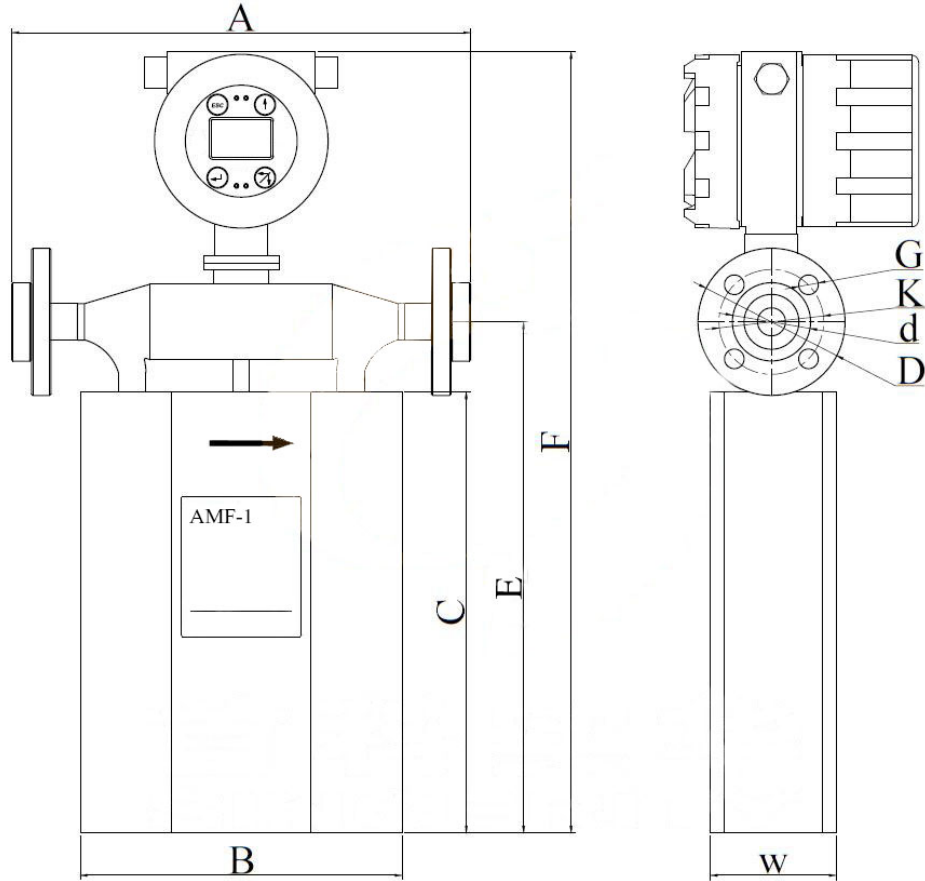

Module	Welded Flange		A	B	C	E	F	W	G	K	d	D
	DN	MPa										
AMF-1-6-AB	65	4.0	560	440	600	715	836	200	18	145	118	185
AMF-1-6-C	100	2.5	670	490	720	831	1052	220	22	190	156	235
AMF-1-6-CD	125	1.6	700	510	790	908	1142	260	18	210	184	250
AMF-1-6-D	150	1.6	900	700	930	1110	1350	280	22	240	211	285

Unit: mm

Dimensions of HighPressure Coriolis Mass Flow Meters
AMF-1-3-A, AMF-1-3-B, AMF-1-4, AMF-1-5-A

Attention: high pressure for AMF-1-5-B, AMF-1-6 modules could be special ordered

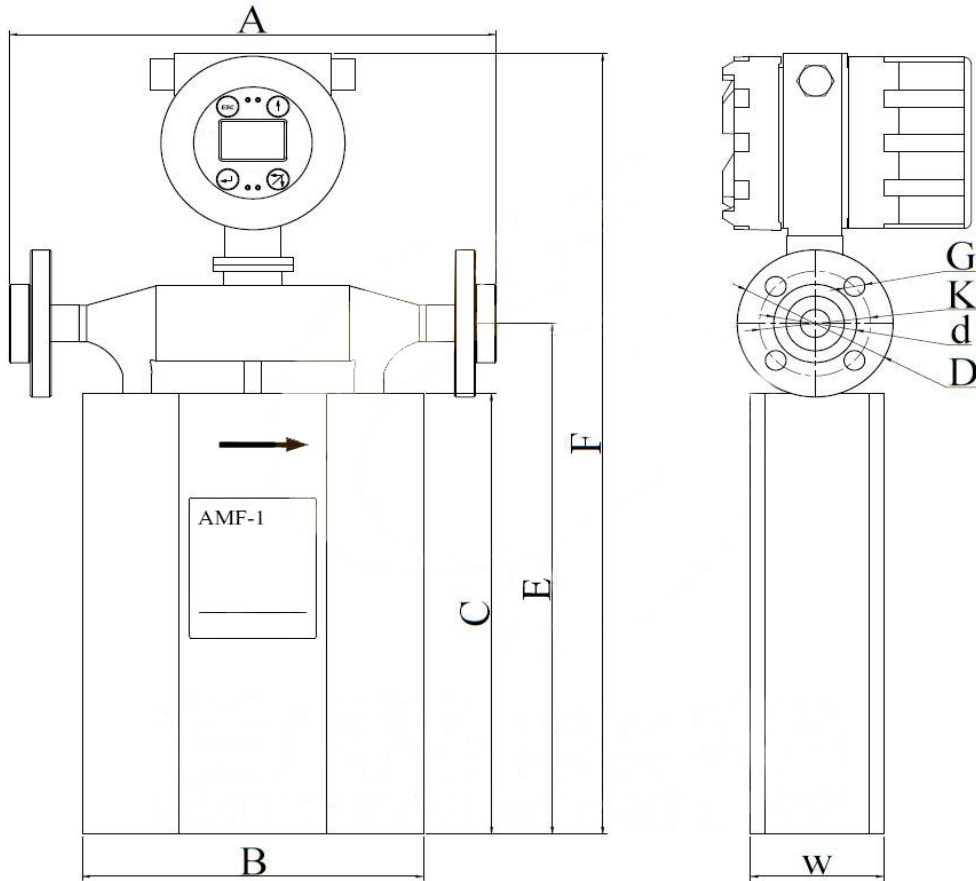

Module	焊接活接头		A	B	C	E	F	W	Φ
	DN	MPa							
AMF-1-3-A	10	25	346	210	235	282	482	80	20×4
AMF-1-3-B	15	25	356	210	275	322	522	80	20×3
AMF-1-4	20	25	376	230	325	372	572	90	20×2

AMF-1-5-A	25	25	460	300	440	500	696	120	31×3
-----------	----	----	-----	-----	-----	-----	-----	-----	------

Unit: mm

Tiny-Flow Coriolis Mass Flow Meters: AMF-1-1, AMF-1-2**Medium-Flow Coriolis Mass Flow Meters: AMF-1-3, AMF-1-4**

Large-Flow Coriolis Mass Flow Meters: AMF-1-5, AMF-1-6



High Pressure Coriolis Mass Flow Meters:



Technical Indicators:

Instantaneous Flow Accuracy: $\pm 0.20\%$ Flow Rate $\pm [(\text{Zero Point Stability}/ \text{Flow Rate}) * 100]\%$ Flow Rate

Response Time: Factory set as 1 second. (could be adjusted by the users)

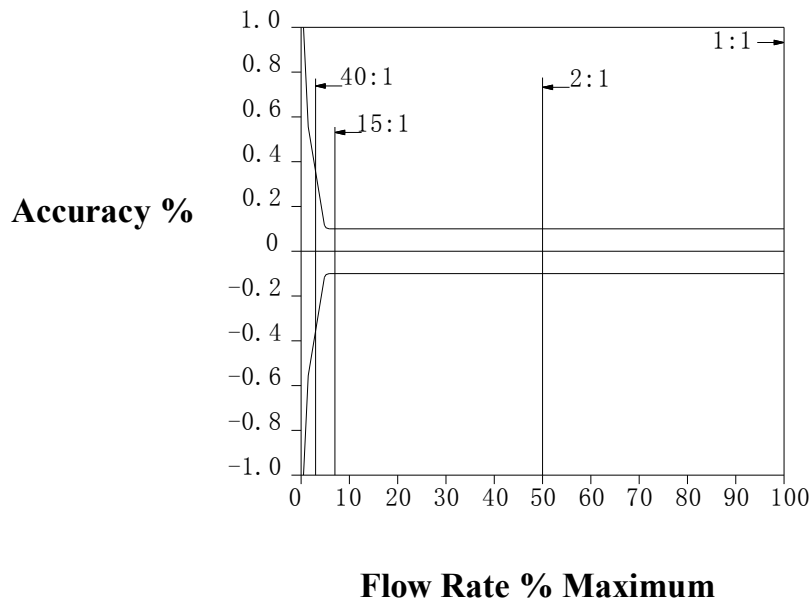
Instantaneous Flow Rate Standard Precision Curve

Density Measurement Accuracy: $\pm 0.002 \text{g/cm}^3$ (Only applicable to liquid)
The origin coordinate starts with 0.5 as the graph shown below:

Density Accuracy Curve:

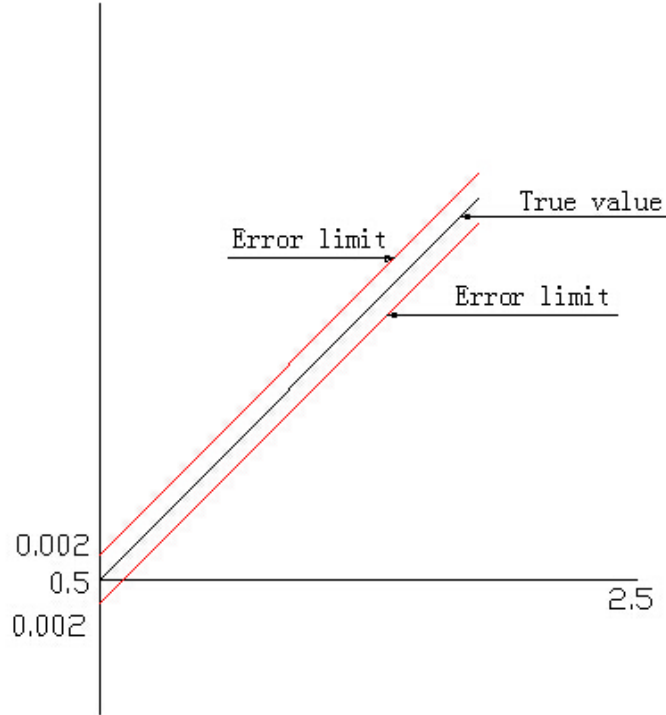

Density Measurement Range: 0.5- 2.5g/cm³

Temperature Measurement Accuracy: $\pm 1^{\circ}\text{C}$

Temperature Accuracy Curve:

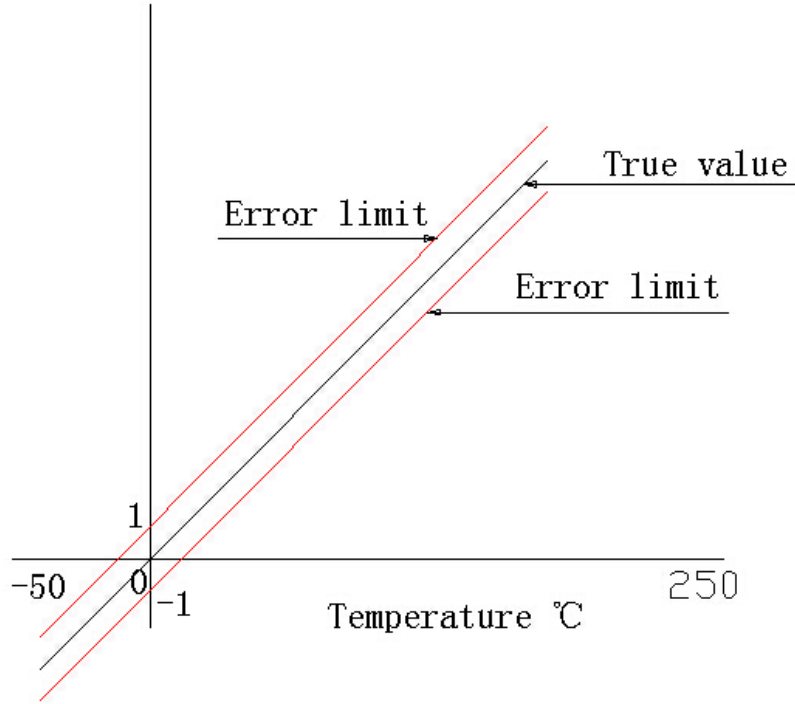

Attention: Module Selection

1. For the measurement of liquid, the most appropriate module should be selected based on the normal flow rate, maximum & minimum flow rate.
2. For the measurement of gas, the most appropriate module should be selected according to the velocity calculated based on normal flow rate, maximum & minimum flow rate, size of pipeline, pressure.
3. For the measurement of high viscosity liquid, or the double-phase liquid of liquid and solid, it is required
4. For the measurement of corrosive medium, would you please inform us the detailed name of the measured medium. And we will select the different materials of measuring pipeline (HC Hastelloy/ PTFE/ Titanium) based on the *Corrosion Prevention Manual*.

We will select the most appropriate module based on the normal flow rate and the maximum flow rate provided. It is recommended that the normal flow rate would be above 1/3 of the designed flow rate range of different modules. And at the same time, it is advised that the minimum flow rate of the users should be above 1/10 of the calibrated flow rate. Please contact us if there's any special requirement. We could provide the customer-made modules based on the special technical requirements of the users. We will make sure the Coriolis Mass Flow Meters would meet all the requirements provided.

We will select the material of the sensor, pressure class and the temperature class based on the characteristics of the medium provided. And for sure, we will guarantee the anti-explosion proof will meet with the actual requirements of the users.

Operation Conditions: Installation

Sensor Installation

The proper installation is very important for the performance of the Coriolis Mass Flow Meters. The installation location should be chosen the place that easy for the maintenance. Would you please read the content of the chapter carefully before the installations

I. Normal Installation

It is recommended to release and empty the gas that possibly stored in the pipeline of the Coriolis Mass Flow Meters before installation.

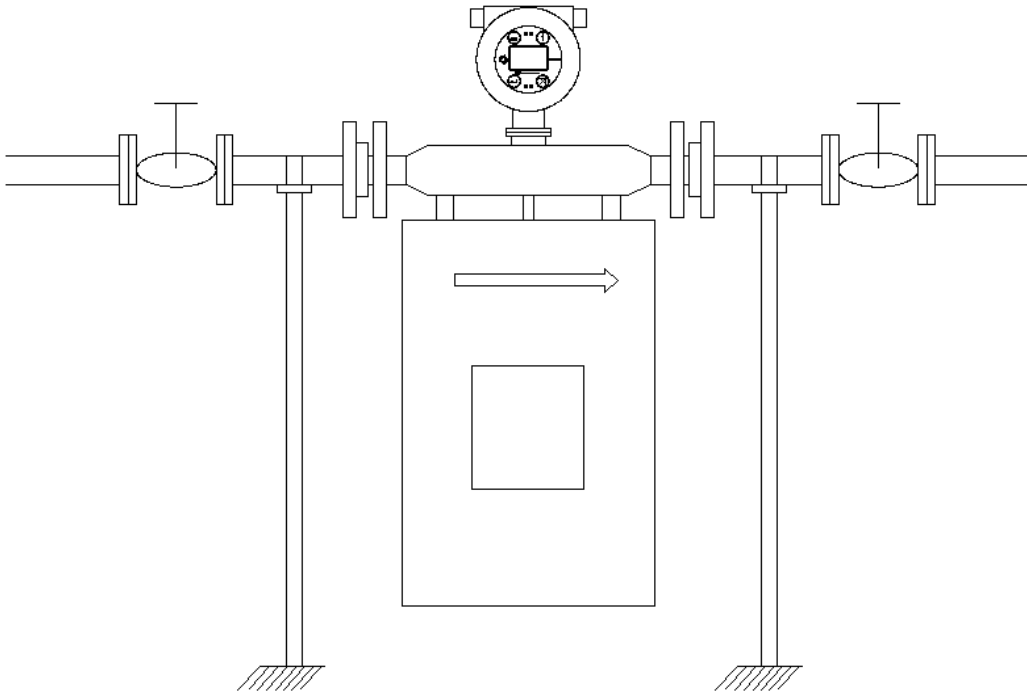

II. Inverted Installation

It is recommended to use the inverted installation for the measurement of Gas (e.g. steam). Because only in this way, the liquid that could possibly stored in the Coriolis Mass Flow Meters could be released and emptied.

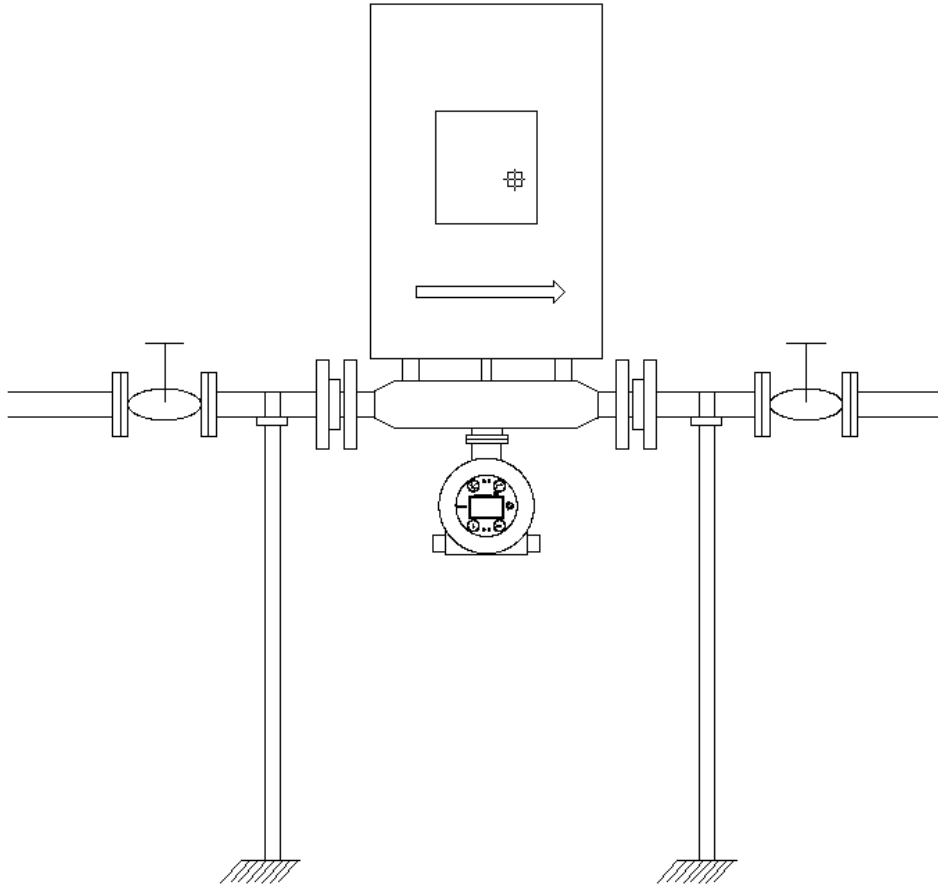

III. Flag- Type Installation

Flag- type installation is the installation way that the Coriolis Mass Flow Meter should be vertical to the horizontal line.

The measurement of suspension liquid, and the double-phase liquid of both liquid and solid is recommended to use the flag-type installation. E.g. For the liquid of easy solidification under the change of temperature, and for the liquid of high viscosity, it is required to empty the liquid left in the measuring pipeline after the measurement. The flag-type installation will not influence the measuring accuracy of the any types of liquid measured. But the direction of the measured flowing must be from bottom up.

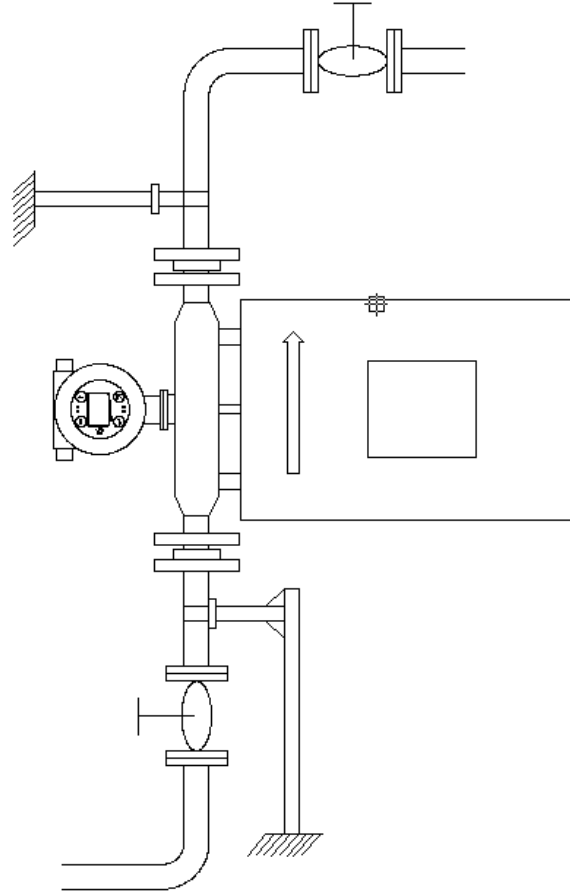

IV. Tiny Pipe-Size (AMF-1-1-A~ AMF-1-2-A) Installation

The tiny- size Coriolis Mass Flow Meters' flow range is very small, while the requirement about the accuracy is high. In this way, then the stable mounting plate and bracket are the must. The installation of mounting plate and Coriolis Mass Flow Meter must be completely flat without any space. If not, please use the level bolt to adjust the balance. The installation of the tiny- size Coriolis Mass Flow Meters is shown as below:

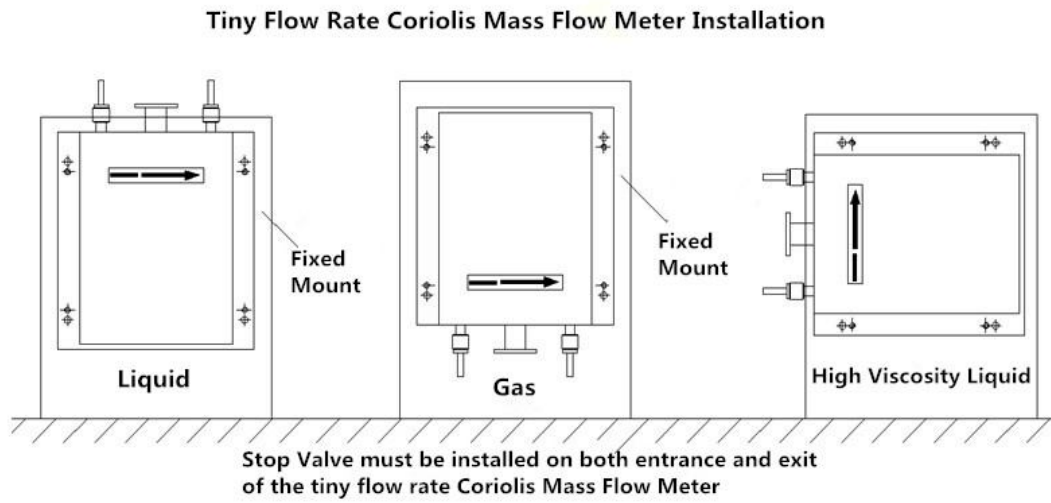

V. Other Installation Requirements

1. Coriolis Mass Flow Meters' measuring principle is based on the controlled generation of vibration. So the installation location should be as far away from the vibration source as possible. And the stable support of the installation pipeline is required too. If the vibration source is inevitable, then it is recommended to use the hose connection. The connecting pipeline and the Coriolis Mass Flow Meter's connection should be located in the same axis. And do not impose an additional force on mass flow meter. Unnecessary additional force will affect measuring accuracy.
2. If the installation of the throttle device is required, such as the flow control valve, then the installation must be installed at the export of the Coriolis Mass Flow Meter.
3. The cut-off valves should be installed at the entry and the export of the Coriolis Mass Flow Meters. And it is benefit for the first-time zero point calibration after the installation.
4. The Coriolis Mass Flow Meter should be as far away from the pump's export as possible, especially the reciprocating pumps. The fluctuation of the flow measurement would be caused by getting too close to the pumps.
5. For the measurement of high temperature liquid, and the heat preservation is required, the insulation shell and the heating pipe must not directly contact with the sensor of the Coriolis Mass Flow Meters. Our company could provide the heat conduction specially designed for the Coriolis Mass Flow Meters Sensors. We could provide the steam heating, or the conduction oil heating. (Should be ordered in advance)
6. The measured liquid should be at a suitable flow state. If the flow state of the liquid is not suitable under the natural environment conditions, then the external improvement is required. It could be used to regulate the temperature of the fluid (heating/ cooling temperature), to make the current fluid to be at the right flow state.
7. Installation Direction: Please make sure that the direction of fluid flowing through the pipeline is the same direction with the arrow on the nameplate of Coriolis Mass Flow Meter.
8. The serial number of the sensor and the transmitter should be one-to-one correspondence. The change or replacement may cause the measurement error of the Coriolis Mass Flow Meters.

Transmitter& Sensor Connection:

The integration of the Coriolis Mass Flow Meter has been connected and installed before the delivery.

The separated transmitter and the sensor are connected by the special connection cables and connectors. If the separation installation of the transmitter and the sensor is required, please contact us in advance before placing the order. The maximum length should not exceed 300m.

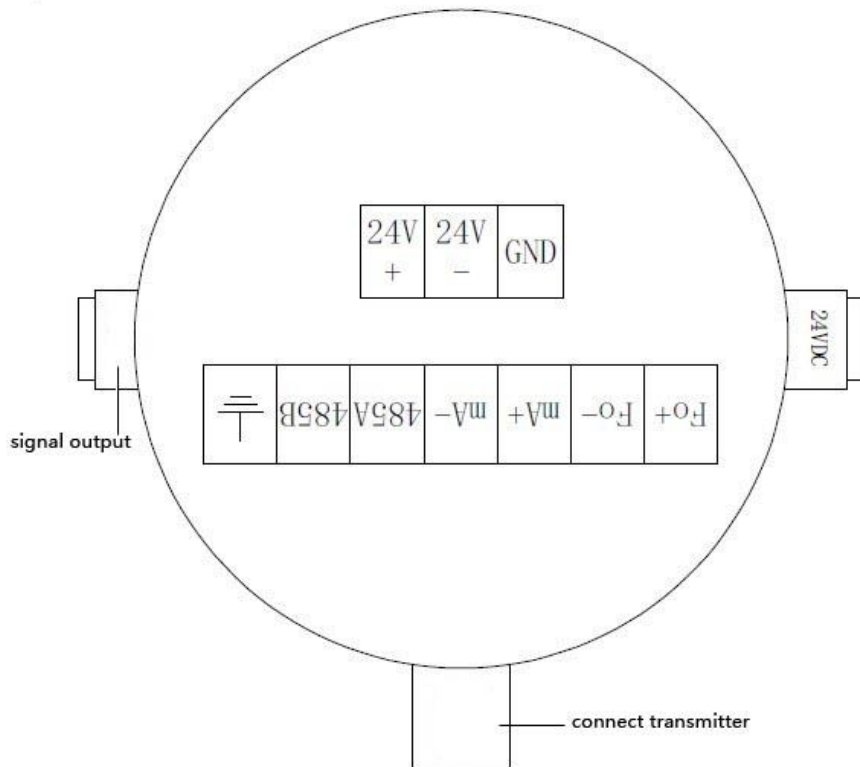

24V+ \-	24VDC Power Supply (Current should not less than 500mA)
Fo + \-	Frequency Output (instantaneous mass flow or volume flow)
mA + \-	Current Output (instantaneous flow or density optional)
485A \485B	RS-485 Communication (Baud Rate: "9600", Address: "1")
GND	Signal Shielding
⏚	Instrument Shell

Attention
<p>The output frequency of the transmitter and the current output must not connect with any level of external power source.</p> <p>Please refer to the anti-explosion part for the technical parameters about the dangerous occasions.</p>

Energizing & Inspection:

- I. Please make sure that the wiring connection is correct before energizing the Coriolis Mass Flow Meters.**

The fault line protection is designed in the transmitters of the Coriolis Mass Flow Meters. But the wrong wiring connection may still cause the damage of the mass flow meters. So please make sure that the wiring connection is correct before energizing the Coriolis Mass Flow Meters.

- II. The screen will display “ Initializing, hold on...” after the energizing**

Maintenance:

Common Trouble-Shooting:

Symptom	Failure Reason	Solution
No display	Check whether is 24VDC power supply is normal	Make sure 24VDC is working normally
Fluctuation of flow rate measured is large	Whether there's strong vibration of the line connected to the sensor	Adding support or switching to hose connection
Could not enter the measuring interface after the boot	Do not connect with the sensor	Check the cables, and make sure they are connected to the sensor properly
Zero Point Drift is large	The installation of the sensor has stress	The connecting line and the sensor interfaces should be at the same axis

Maintenance and Repair:

The lifetime of the coriolis mass flow meters is related to the maintenance and repair. To extend the lifetime of the coriolis mass flow meters, please follow the steps listed as below:

1. Keep the mass flow meters clean, and try not to put in the dirty environment. And prevent from the explosion under the sunshine, and keep it away from water.
2. Carry and place the coriolis mass flow meters gently, and do not throw it.
3. Clean the measuring pipelines inside the mass flow meters regularly. For the medium with high viscosity, it is recommended to clean more often.
4. For the customers with high accuracy requirements, it is recommended to calibrate the mass flow meters regularly.

Settings

I. Function Settings:

i. User's menu password

The user's menu password is 20.

This password can be used for checking the records, modifying the settings, testing the output, and clearing the fault codes, etc.

ii. System Menu Password

The system menu password is associated with the calibration parameters of the Coriolis Mass Flow Meters, and it is not recommended to modify. If it is required, please contact our company for the after-sales department. And please operate under the guidance of the relevant technical engineers. Thank you

iii. Unit Selection

The range conversion is automatically processed under selecting different units.

t/h	kg/min	L/min
kg/h	g/min	mL/min
g/h	m³/h	pounds/min

iv. The selection of the decimal

The display of 0- 3 decimal places is optical.

v. Current Output Setting

Flow/ Density (4-20)mA output

vi. Frequency/ Pulse Output Setting

Frequency output or pulse output are optional.

Frequency output is corresponding to the instantaneous mass flow, or volumetric flow.

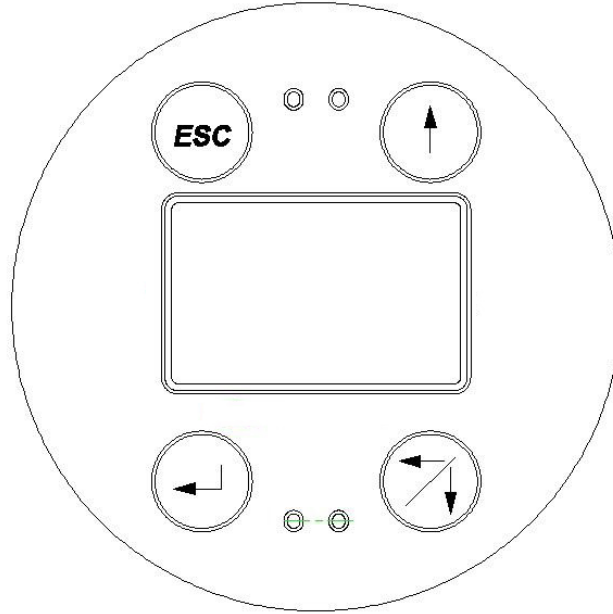

II. Instrument Panel



III. Operating Interface:

The touch button of the operating interface is light touch button. Please directly touch the button to operate.

Boot Display:

Touch  or  to switch between two interfaces:

Instant Flow	
22.356	Kg/h
Total Flow	
3256.562	kg

Density	
1.000	g/cm3
Temp	
25.3	°C

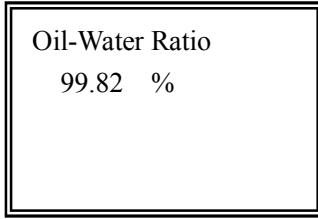

***Customization Order: please contact us in advance if it is required**

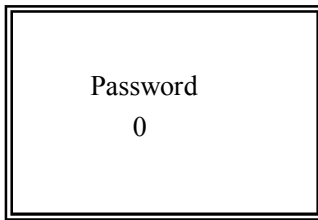

Touch  , and it will be displayed as below:



Check the Record:

Touch  , and touch  , input 20 (password). Then touch  to enter.

Enter the interface:

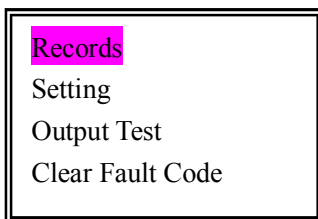

Touch  to enter the next menu.



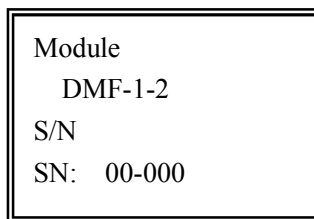
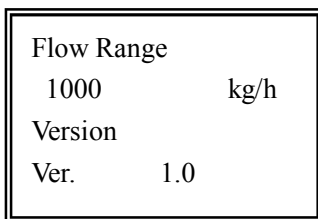

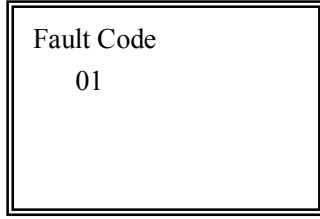
Touch  to scroll between several interfaces to check the information of the mass flow meters





Touch “ESC” to enter the previous menu

Setting

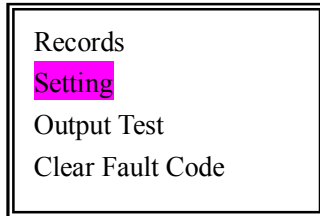

Touch , touch  to enter 20, then touch  to enter the next interface. And touch  to enter the “Setting” interface.

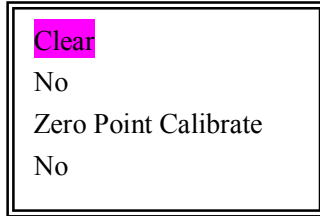

Touch  to enter



For Example: 1) when the cursor is at “Clear”, touch  to move to “Zero Point Calibrate”;

2) Touch  to enter, touch  to choose yes, or no. Touch  to enter. Or touch “ESC” to exit.

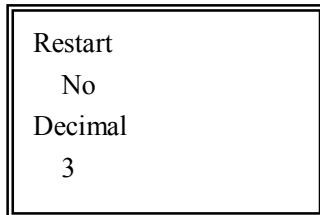

The mass flow meter will be restarted by touching this button.

The decimal set for the mass flow meter is optical from 0-3

Order	
Instant Flow	
Unit	
Kg/h	g/cm ³

The unit set for the unit of the flow could be optical as below: t/h, kg/h, g/h, kg/min, g/min, m³/h, L/min, mL/min. If choosing the mass unit (volume), then the flow rate measured would be mass (volume).

Tiny-Signal Terminate	(0~99) % Optical
1%	
Response	(0~100) s Optical
0	

Light	
On	
Current Output	
Flow Rate	

Choose the flow rate or density (4-20mA) output
The density range is 0.5g/cm³~2.5g/cm³

***Customization Order: please contact us in advance if it is required.**

Density 1:	
1.000	g/cm ³
Density 2:	
0.800	g/cm ³





Please enter the density of these two medium: the density of medium 1, and medium 2.

The measuring interface would show the percentage of density 2.

ATTENTION:

1. The density input for these two medium should not be equal.
2. The percentage is under the saturated processing. (0-100%)

Output Test

Touch  , touch  to enter 20, then touch  to enter the next
34 

interface. And touch  to enter the “Setting” interface.

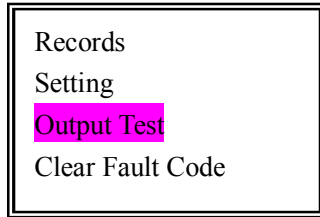

This test will be used to test the (0-10)KHz pulse output signal, and (4-20)mA current output.

Touch  to enter the interface

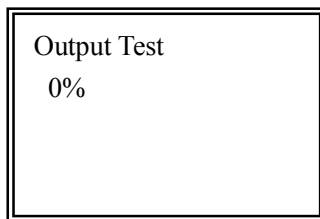





Touch  to transfer the testing point

	0%	25%	50%	75%	100%
(0—10)KHz	0KHz	2.5KHz	5KHz	7.5KHz	10KHz
(4—20)mA	4mA	8mA	12mA	16mA	20mA

ATTENTION: The (0-10)KHz and (4-20)mA output signal are standard equipped with the power supply. It is forbidden to connect to the external power source. Otherwise it may cause damage of the Coriolis mass flow meters.

Clear Fault Code:

Touch , touch  to enter 20, then touch  to enter the next interface. And touch  to enter the “Clear Fault Code” interface.

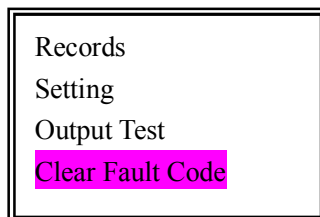

It's used to clear the history fault records.

Touch  to enter

Clear Fault Code
No

Touch  to choose “yes”, or “no”

Touch  to enter. Or touch “ESC” to exit.

IV. Zero Point Calibrate

Zero point calibration provides the datum point of the flow measurement. The zero point calibration must be conducted after the first time installation or re-installation.

The zero point calibration must be processed by cutting off the downstream shutoff valve firstly, and then cutting off the upstream shutoff valve. And make sure the sensor is fully filled with liquid during the process of zero point calibration.

Explosive Prevention

Principles of Anti-Explosion Systems:

DMF-Series Coriolis Mass Flow Meters are consist of the transmitter, sensor (It is equipped with the dedicated security gate). The DMF-Series Coriolis Mass Flow Meters are intrinsically safe explosion-proof products. Transmitters are associated apparatus especially for the sensors, and they adopt the flameproof shell. The explosion-proof is: EX d ib II C T5 Gb

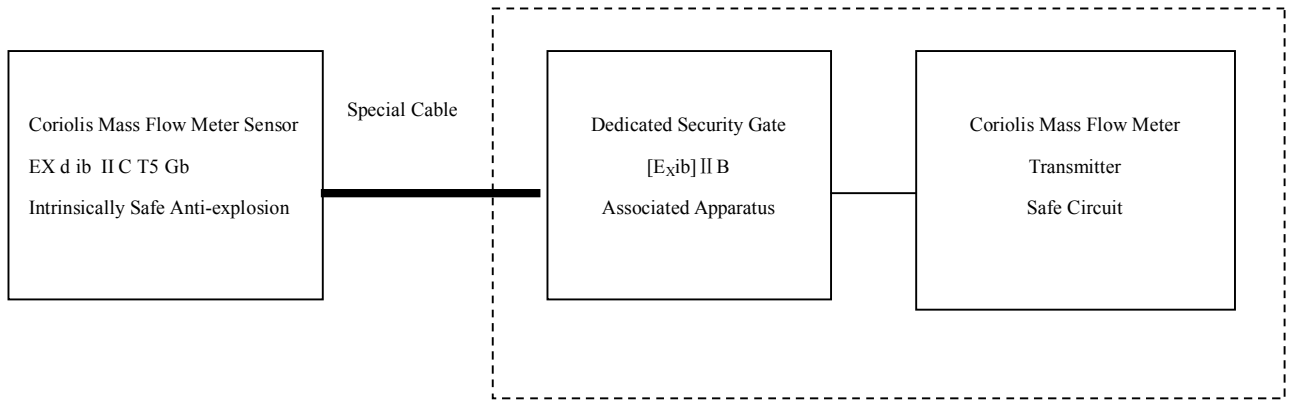

Explosion-proof Performance

Explosion-proof Performance meets with the terms of GB 3836.1-2010 and GB 3836.4-2010.

Explosion-proof Performance Test

Explosion-proof Performance inspection certification department conducts the test of the electrical products according to the terms of GB 3836.1-2010, GB 3836.2-2010 and GB3836.4-2010

Documentation: RS 485 RTU Communication Protocol

Address:

S/N.	Holding Register	Access Address (Hex/ Decimal)	Definition
1	41001	0x03E8 / 1000	Mass Flow
2	41003	0x03EA / 1002	Volume Flow
3	41005	0x03EC / 1004	Total Mass
4	41007	0x03EE / 1006	Total Volume
5	41009	0x03F0 / 1008	Density
6	41011	0x03F2 / 1010	Temperature
7	41013	0x03F4 / 1012	Pipeline Vibration Frequency
8	41015	0x03F6 / 1014	Module
9	41017	0x03F8 / 1016	S/N
10	41019	0x03FA / 1018	Flow Unit
11	41021	0x03FC / 1020	Density Unit
12	41023	0x03FE / 1022	Range
13	41025	0x0400 / 1024	Decimal Places
14	41027	0x0402 / 1026	Tiny Signal Cut Ratio
15	41029	0x0404 / 1028	Display Refresh Time
16	41031	0x0406 / 1030	Internal Mass Flow Meter Parameters
17	41033	0x0408 / 1032	Internal Mass Flow Meter Parameters
18	41035	0x040A / 1034	Internal Mass Flow Meter Parameters
19	41037	0x040C / 1036	Measured Medium
20	41039	0x040E / 1038	Current Output Selection
21	41041	0x0410 / 1040	Input Password
22	41043	0x0412 / 1042	Internal Mass Flow Meter Parameters
23	41045	0x0414 / 1044	Internal Mass Flow Meter Parameters
24	41047	0x0416 / 1046	Internal Mass Flow Meter Parameters
25	41049	0x0418 / 1048	Total Data Clearance
26	41051	0x041A / 1050	Internal Mass Flow Meter Parameters
27	41053	0x041C / 1052	Internal Mass Flow Meter Parameters
28	41055	0x041E / 1054	Internal Mass Flow Meter Parameters
29	41057	0x0420 / 1056	Internal Mass Flow Meter Parameters
30	41059	0x0422 / 1058	Internal Mass Flow Meter Parameters
31	41061	0x0424 / 1060	Internal Mass Flow Meter Parameters
32	41063	0x0426 / 1062	Internal Mass Flow Meter Parameters
33	41065	0x0428 / 1064	Internal Mass Flow Meter Parameters
34	41067	0x042A / 1066	Internal Mass Flow Meter Parameters
35	41069	0x042C / 1068	Internal Mass Flow Meter Parameters
36	41071	0x042E / 1070	Internal Mass Flow Meter Parameters

Attention:

Each holding register is 4 bytes (2 consecutive maintain registers), and it takes two addresses (low address). The register with a background in the tables is read-only register. The writing operation is invalid.

The address of 0x41049 is total-data clearance register. Write 0 in this address could process the clearance operation. Read the register and it will returns back to 1 (Floating point number).

The flow unit setting is 0-7 (The data will be transferred to 4-byte floating point number to transfer).

0→t/h; 1→kg/h; 2→g/h; 3→kg/min ; 4→g/min; 5→m³/h; 6→L/min; 7→ml/min

The density unit setting is 0-2 (The data will be transferred to 4-byte floating point number to transfer). And it respectively stands for: g/cm³、 g/L、 t/m³

0→ g/cm³; 1→g/L; 2→t/m³

The current output selection is 0-1. And it respectively stands for flow and density. The data will be transferred to 4-byte floating point number to transfer.

The measured medium setting is 0-1. And it respectively stands for liquid and gas. The data will be transferred to 4-byte floating point number to transfer.

ModBus Communication (RTU Format)

Check Method: no check

Data Bits: 8

Stop Bits: 1

ModBus Communication Protocol (RTU)

1. Read N variables

The host requested information frame:

Mass Flow Meter Address+0x03+Register's Starting Address (2bytes, High Byte is in the front) + Number of Register's Reading and Writing 2*N (2bytes, High Byte is in the front) + CRC Check Code (2bytes, Low Byte is in the front)

Response Information from the machine frame:

Mass Flow Meter Address +0x03+Bytes of Data 4*N (1 字节) + Register's Data (4*N bytes, High Byte is in the front) + CRC Check Code (2 bytes, Low Byte is in the front)

For Example:

2. Write N variables

The host requested information frame:

Mass Flow Meter Address +Function Code 0x10+ Register's Starting Address(2 bytes, High Byte is in the front)+ Number of Register's Reading and Writing 2*N(2bytes, High Byte is in the front) + Bytes of Data 4*N (1byte) +Data waiting to be written (4*N bytes, High Byte is in the front) + CRC Check Code (2 bytes, Low Byte is in the front)

Response Information from the machine frame:

Mass Flow Meter Address + Function Code 0x10+ Register's Starting Address (2 bytes, High Byte is in the front) Number of Register's Reading and Writing 2*N (2bytes, High Byte is in the front) + (2 bytes, Low Byte is in the front)