



Dissolved Oxygen Analyzer

Data Sheet

Dissolved Oxygen Analyzer DOM 5.0

Product description:

DOM 5.0 Dissolved Oxygen analyzer adopts fluorescence method to measure dissolved oxygen. The cap of the sensor is coated with a luminescent material. Blue light from an LED illuminates the luminescent chemical. The luminescent chemical instantly becomes excited and releases red light. The time and intensity of red light are inversely proportional to the concentration of oxygen molecules, So the concentration of oxygen molecules is calculated.



DOM 5.0 Dissolved Oxygen meter

Application:

-Wastewater treatment plants:

- O₂ control in the aeration basin
- Process water treatment and monitoring

-Water works:

- Status monitoring of drinking water (oxygen enrichment, corrosion protection, etc.)
- Water quality monitoring in rivers, lakes or seas

-Utilities of all industries:

- O₂ control in the biological treatment
- Process water treatment and monitoring

-Fish farming:

- O₂ control for optimum growth conditions

Features

- The sensor adopts new type of oxygen sensitive membrane,with NTC temperature compensated function,whose measurement result has good repeatability and stability.
 - Won't produce oxygen consumption when measuring and no requirement of flow rate and stirring.
 - Breakthrough fluorescence technology,without membrane and the electrolyte and almost not need maintenance.
 - Built-in self-diagnosis function to ensure the accuracy of data.
 - Factory calibration,not need calibration for a year and can carry out field calibration.
-

Technical Specifications:

Measurement range	DO: 0-20 mg/L、 0-20 ppm; Temperature: 0-45°C
Measurement Accuracy	DO: ±3% of the measured value; Temperature: ±0.5°C
Pressure range	≤0.3Mpa
Calibration	Air automated calibration,sample calibration
Main material	Body: SUS316L + PVC (fresh water) , Titanium alloy (marine) O-ring: fluorine rubber; Cable: PVC
Power supply	AC:100-240VAC (50/60HZ)DC: 9~36VDC
Output	2-way 4-20mA
Relay	Setting three-way relays,programmed response parameter and response value.
Communication protocol	MODBUS RS485
Storage temperature	-15-65°C
Measuring temperature	0-45°C
Dimensions	Sensor: Dia55mm*L 342mm Transmitter: 145*125*162mm(L*W*H)
Weight	Sensor: 1.85KG; Transmitter: 1.35KG
Protective rate	Sensor: IP68/NEMA6P; Transmitter: IP65/ NEMA4X
Cable length	Standard: 10m, the maximum may be extended to 100m

Measuring principle

- **Sensor design:**

- Oxygen-sensitive molecules (markers) are integrated in an optically active layer (fluorescence layer).
- The surface of the fluorescence layer is in contact with the medium.
- The sensor optics are directed at the underside of the fluorescence layer.

- **There is an equilibrium between the oxygen partial pressure in the medium and that in the fluorescence layer:**

- If the sensor is immersed in the medium, the equilibrium is established very quickly.

- **Measuring process:**

- The sensor optics send green light pulses to the fluorescence layer.
- The Oxygen-sensitive molecules instantly becomes excited and releases red light.
- The duration and intensity of the response signals is directly dependent on the oxygen contents and the partial pressure.
- If the medium is free from oxygen, the response signals are long and very intense.
- Oxygen molecules quench the Oxygen-sensitive molecules. As a result, the response signals are shorter and less intense.

- **Measurement result:**

- The sensor returns a signal that is in proportion to the oxygen concentration in the medium.
- The medium temperature and air pressure are already taken into account calculated in the sensor.
- In addition to the standard values of concentration, saturation index and partial pressure, the sensor also returns a raw measured value in μs . The value corresponds to the decay time of the fluorescence and is approx. 20 μs in air, and approx. 60 μs in media free from oxygen.

Installation dimension

① dissolved oxygen transmitter

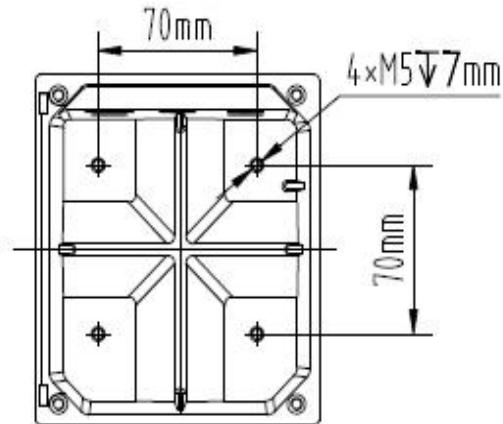
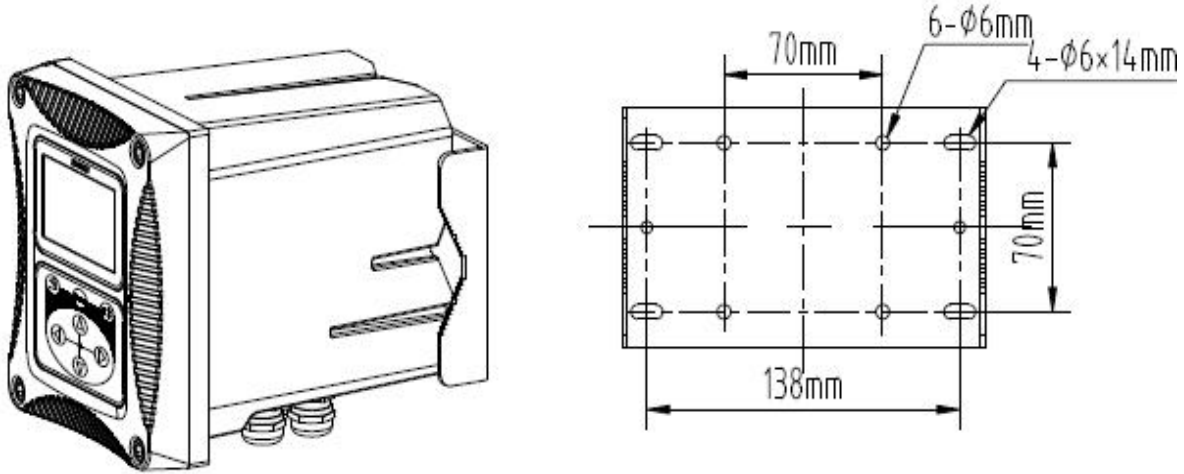

② dissolved oxygen sensor

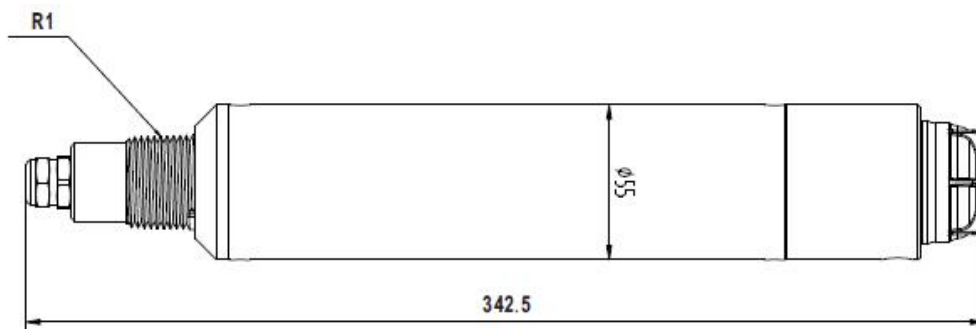

Installation

A. Installation way of clamp

Place the transmitter and the mounting plate on both sides of the clamp, then use the mounting bolts and nuts to secure the transmitter and the mounting plate to the clamp, as shown in figure 4.

B. Wall installation

Attach the transmitter with mounting bolts and nuts to the mounting plate, and then fixed the mounting plate on the mounting wall or board.

C. Panel installation

Set the transmitter into the panel , and then fixed the transmitter with nuts and bolts on the panel, as shown in figure 5. Figure 6 shows the bottom view and the top view.

In the installation way of clamp, the diameter of clamp is 1 inch to 2.5 inches.

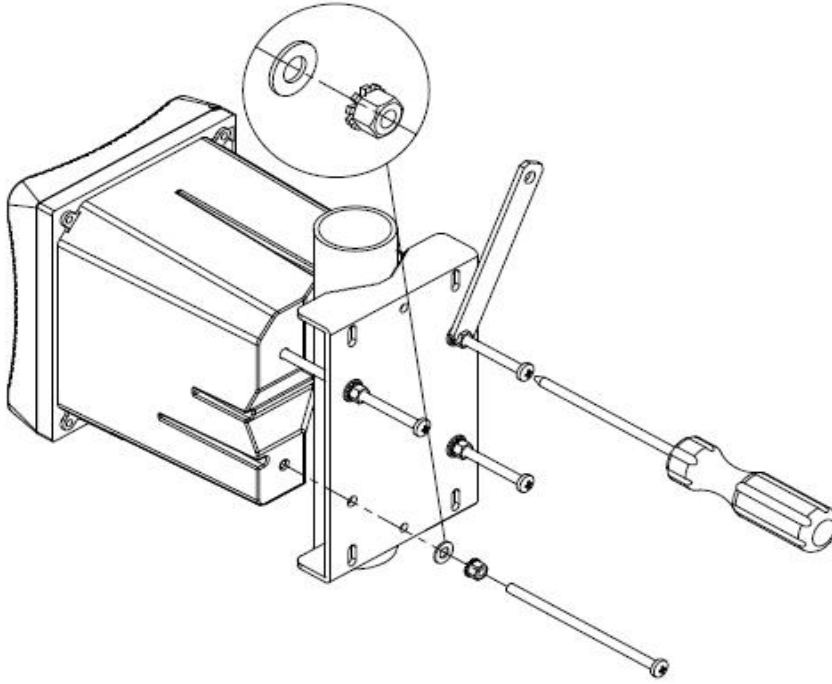

Figure 4 Installation Way of Clamp

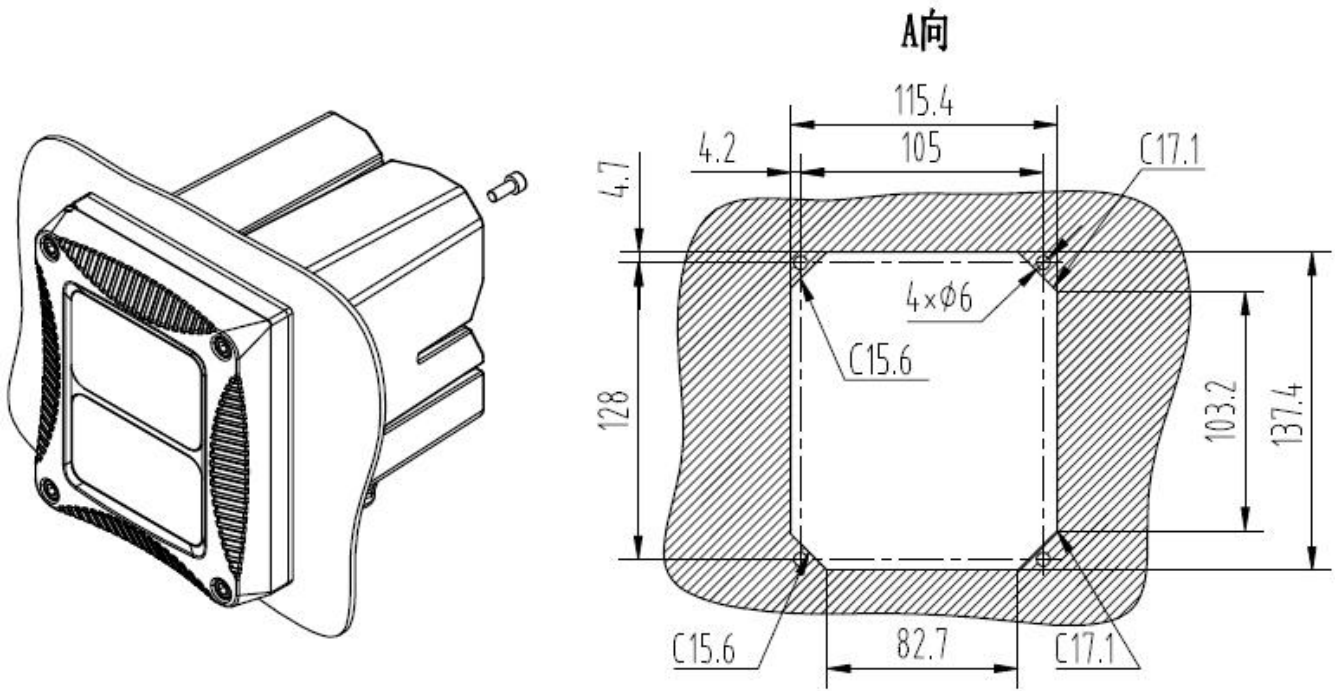
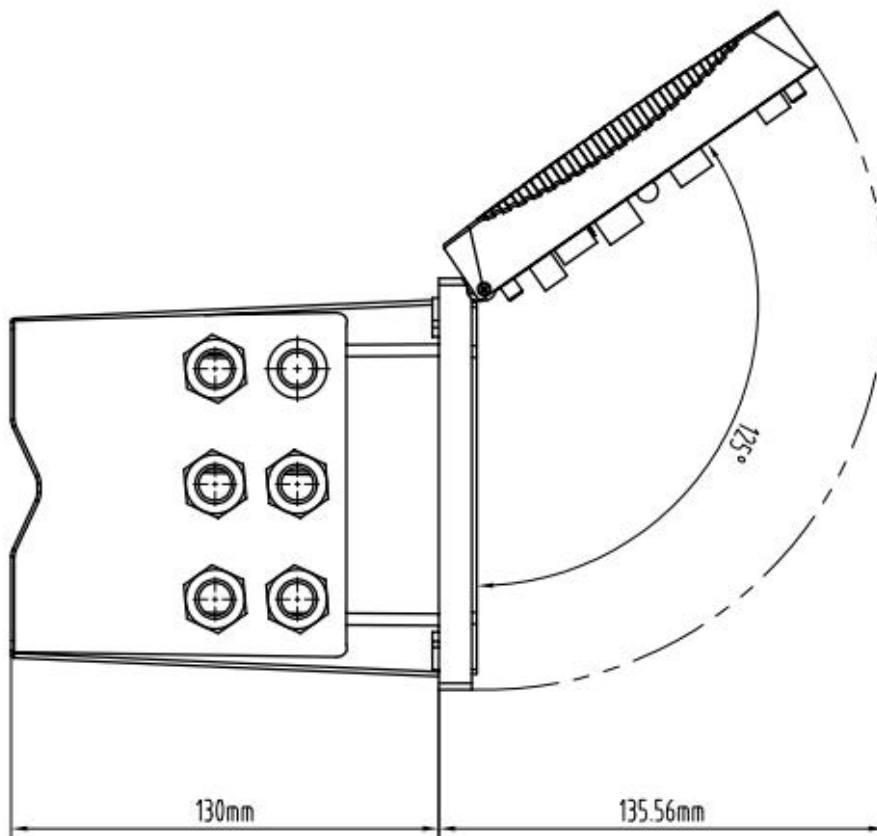

Figure 5 Panel Installation



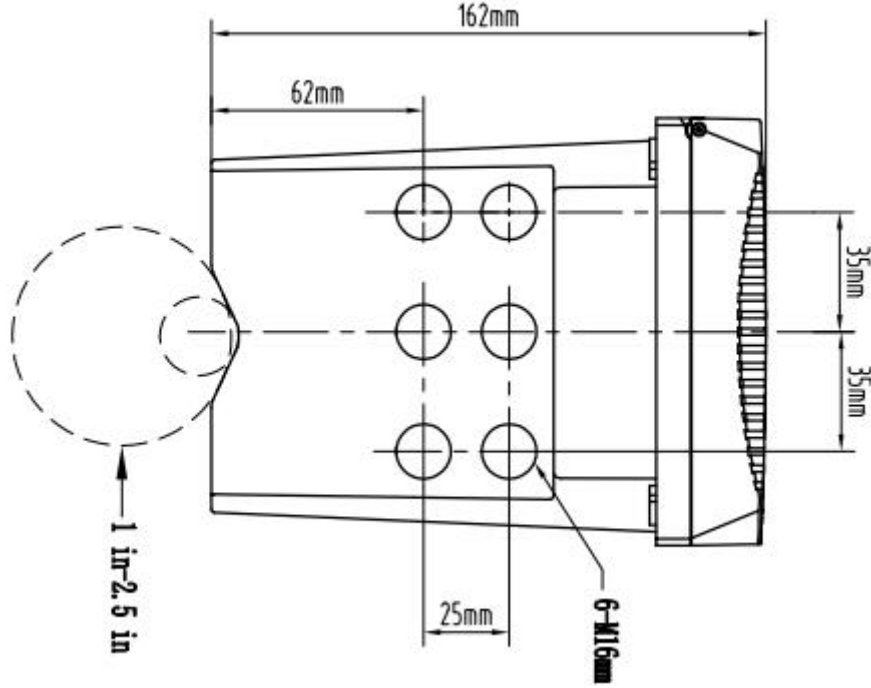

Figure 6 Bottom View, Top View