

USER'S GUIDE

Installation & Operation

Instructions

Ultrasonic Level Meter

Model ALIT-BT

INDEX

WORKING PRINCIPLE	3
QUICK BENCH TEST	3
CONNECTIONS	4
KEYPAD SYSTEM	5
MENU-FLOW CHART	5
THE NORMAL MODE	7
THE SETTING MODE	7
MOUNTING.....	10
TROUBLE SHOOTING.....	15

WORKING PRINCIPLE

Time-of-flight method: the sensor of the meter pulses in the direction of the product surface. There, they are reflected back and received by the sensor. The meter measures the time t between pulse transmission and reception. The meter uses the time t (and the velocity of sound c) to calculate the distance D between the sensor bottom and the target surface with the formula " $D = c \cdot t/2$ ". As the device knows the H (installation height) from user calibration, it can calculate the level as follows: $L = H - D$, referring to the below diagram:

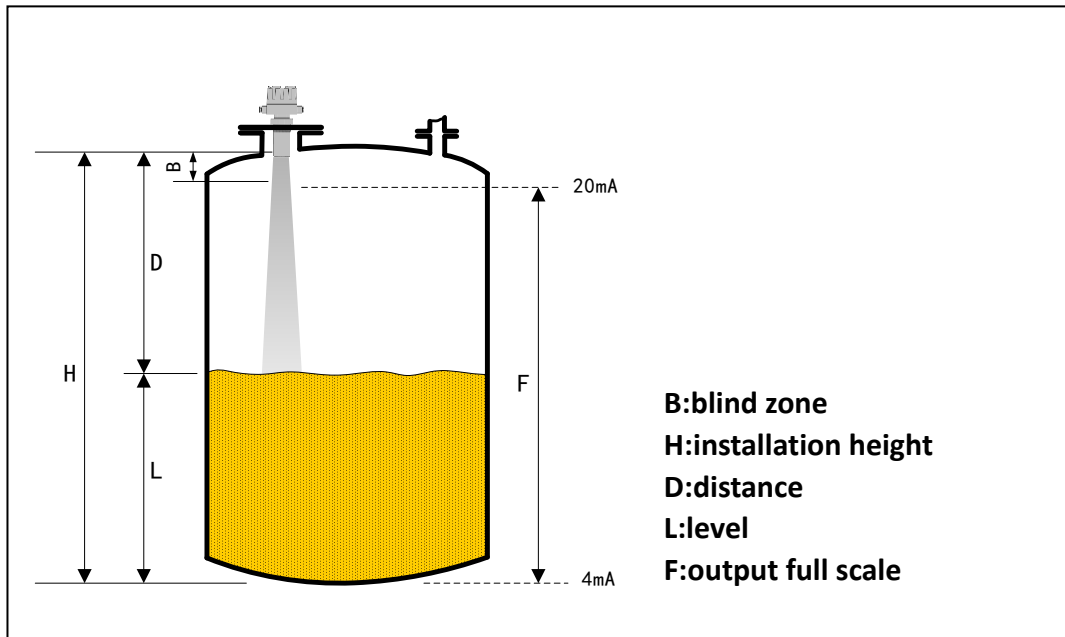

An integrated temperature sensor compensates for changes in the velocity of sound caused by temperature changes. Calibration Enter the empty distance H and the span F to calibrate the device.

Blind zone: Span F may not extend into the blind zone B . Level echo from the blind zone cannot be evaluated due to the transient characteristics of the sensor.

QUICK BENCH TEST

Connect the meter as shown below, then apply Power. When properly connected a soft clicking can be heard from the sensor and figures will show on the LCD display. Test operation of the ALIT-BT by holding the meter steadily and aiming the sensor at a flat and stable target away from the end of the sensor. Allow a few seconds for the ALIT-BT to lock onto the target before displaying its distance. The ALIT-BT will display range in meter.

Notes:

1. The ALIT-BT is DC24V power supply, the power should be not less than 30 mA current output.
2. The ALIT-BT will not detect targets in the dead zone and beyond the user ordered maximum range. And make sure that the sensor and the measured target surface is vertical and there is no obstacle.
3. After power, the meter will show ALIT for a few seconds and then showing the level value.
4. Press SEL key to observe the distance value and the temperature. The level value, distance value and the temperature will show in turns.

CONNECTIONS

Power input: The ALIT-BT is 2- wire series ultrasonic level meter, it requires DC power between 20 to 32VDC. No adjustments are necessary for any voltage in this range.

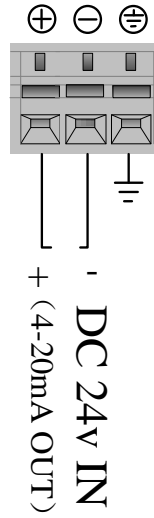

KEYPAD SYSTEM

The ALIT-BT has a simple 3-key calibration system. Operating and calibration modes are shown on the 4-digit display. The keys are used to calibrate the ALIT-BT, and to view operating mode and functions.

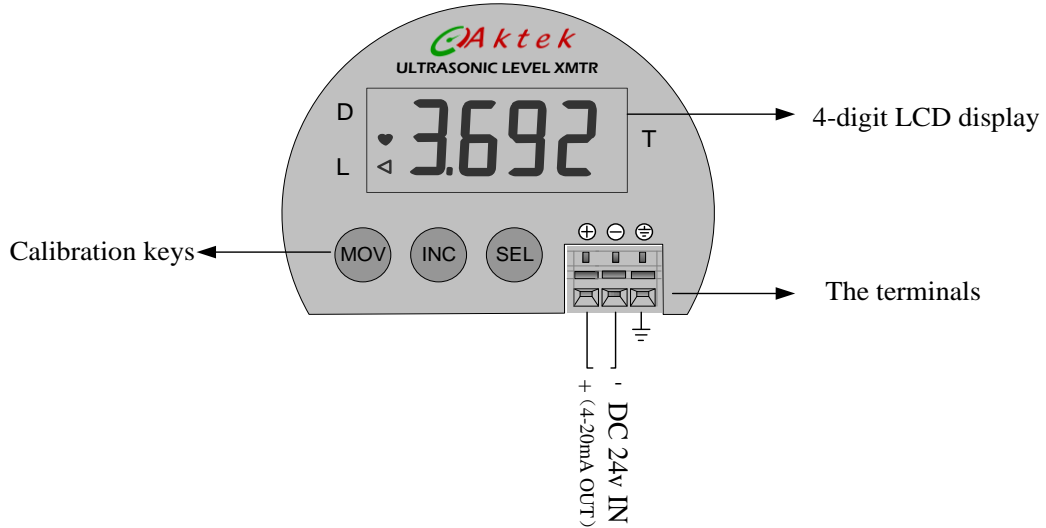

MENU-FLOW CHART

The following diagram shows the ALIT-BT Menu system. Arrows show the directions to leave a box. Pressing a corresponding key will move to the next box in the direction shown. Numeric values are changed by pressing the **INC** key.

To store the calibration values permanently, press the **SEL** key.

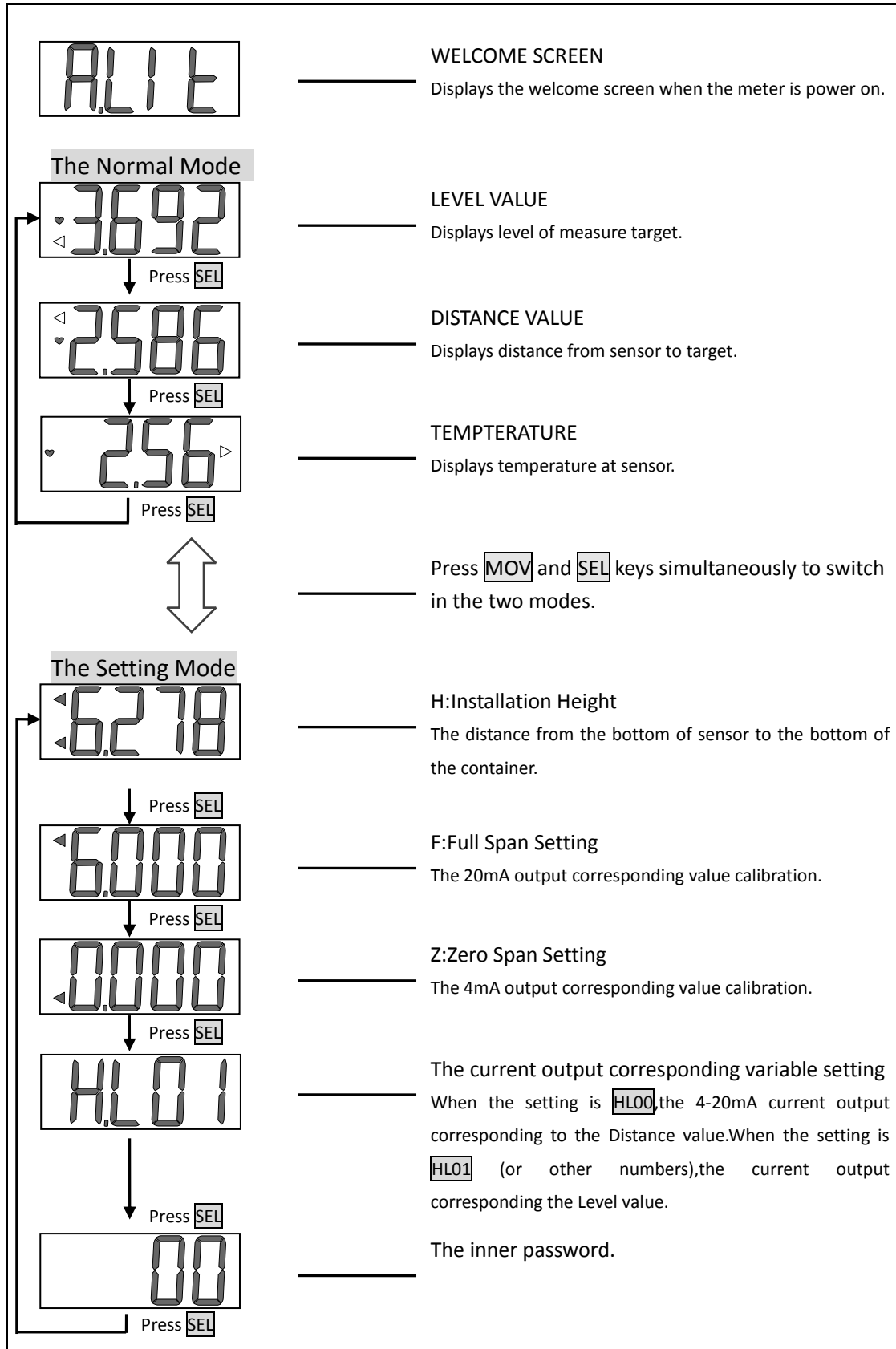

THE NORMAL MODE

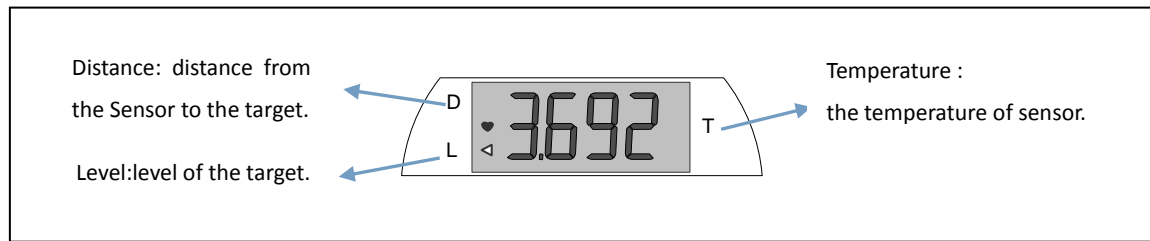

Notes:

1. After powered, the meter shows ALIT for seconds, and then the corresponding measurement.
2. Press SEL to the next display. The L (level), D (distance) and T (temperature) will show in turns by pressing SEL, MOV and INC keys in normal mode are invalid.
3. The symbol ♥ is flashing, which means there are good echoes received.
4. The shown variable number of LCD is corresponding to the indication of ◁. In the above sample, the symbol ◁ is corresponding to L, means the level of the measured target is 3.692m.
5. The unit of temperature is centigrade (°C), the unit of distance is meter(m).

THE SETTING MODE

Press MOV and SEL keys simultaneously from normal mode, then will enter setting mode. (Do not press keys more than 1 seconds, or else the meter will restart.) The display will show the installation height calibration, full span setting(20mA), zero point setting(4mA) and the current output corresponding variable setting.

Installation height calibration

Press MOV and SEL keys simultaneously from normal mode, display will show installation height calibration parameters as below.

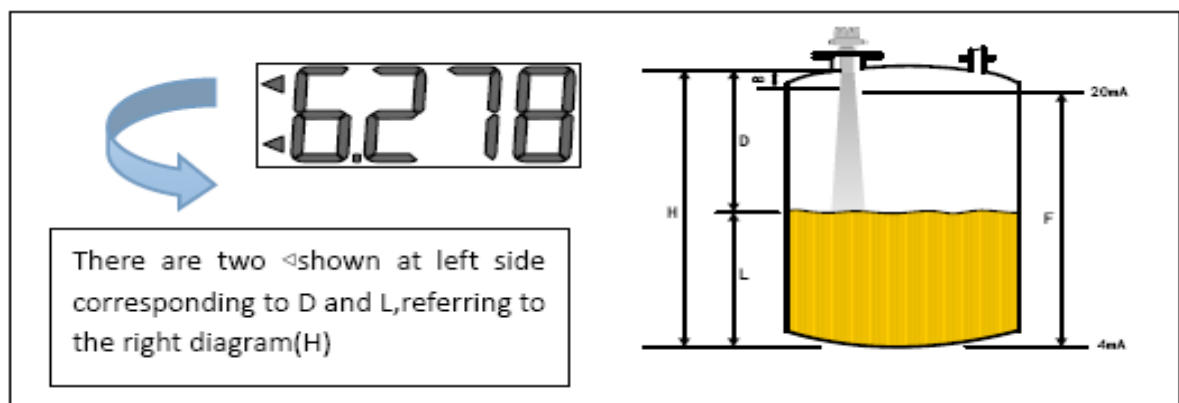

The calibration procedures referring to the following:

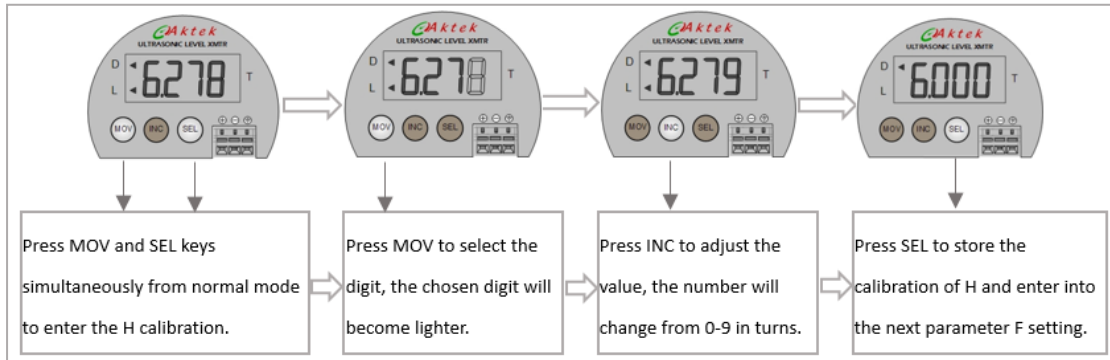

Notes:

1. The H (installation height) must be accurately set according to the actual situation, otherwise the level value will be wrong.
2. The H value should not be less than D (distance), otherwise there will be wrong value of L (level).
3. In the setting mode, press **SEL** key can store the calibration and enter into next parameter.

Full span setting---20mA output calibration

The second parameter in the setting mode is F (full span setting), for the calibration of the 20mA current output corresponding value. Press **SEL** to enter the F setting, the display will show the full span setting parameters as below:

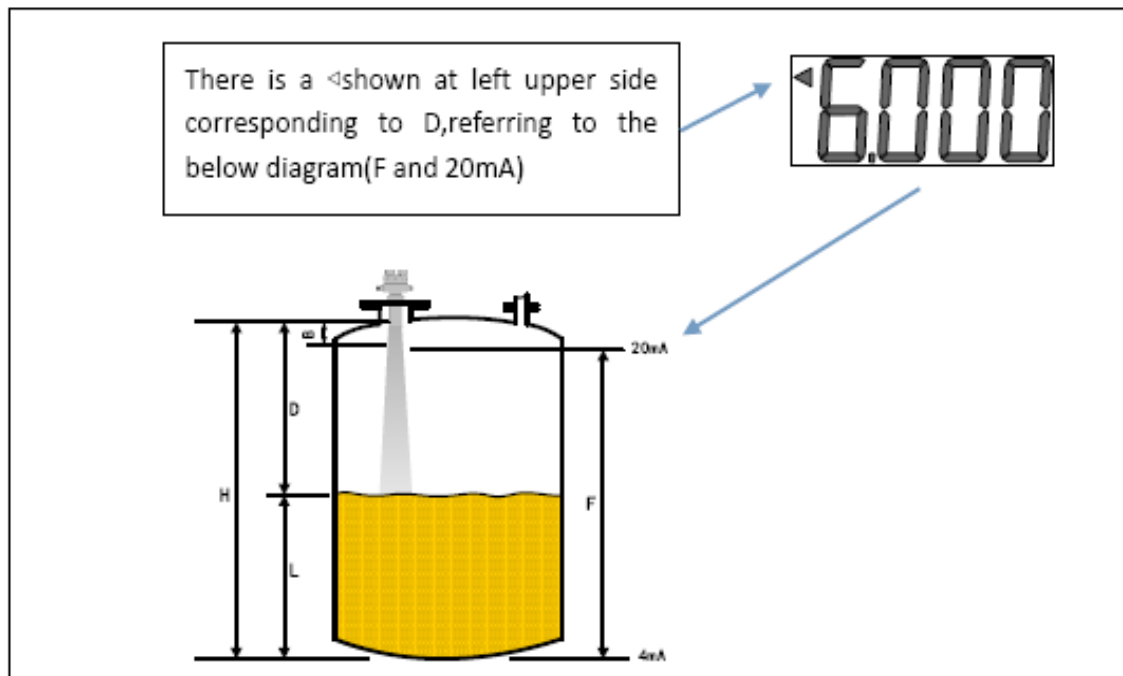

Note: follow the same procedure to calibrate the parameter with **MOV** and **INC** keys, then press **SEL** to store the calibration and enter into the next parameter.

Zero point setting---4 mA output calibration

The third parameter in the setting mode is Z (zero point setting), for the calibration of the 4mA current output corresponding value. Press **SEL** to enter the Z setting, the display will show the zero point setting parameters as below:

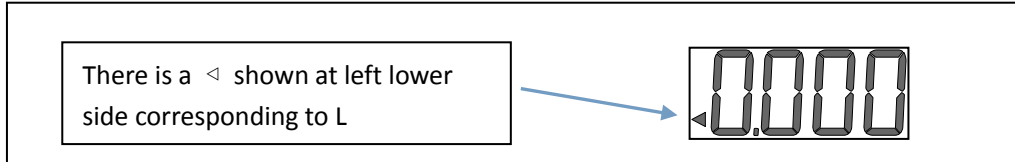

Note: follow the same procedure to calibrate the parameter with **MOV** and **INC** keys, then press **SEL** to store the calibration and enter into the next parameter.

The current output corresponding variable setting

The fourth parameter in the setting mode is the current output corresponding variable setting. When the setting is **HL00**, the 4-20mA current output corresponding to the Distance value. When the setting is **HL01** (or other numbers), referring to below diagram:

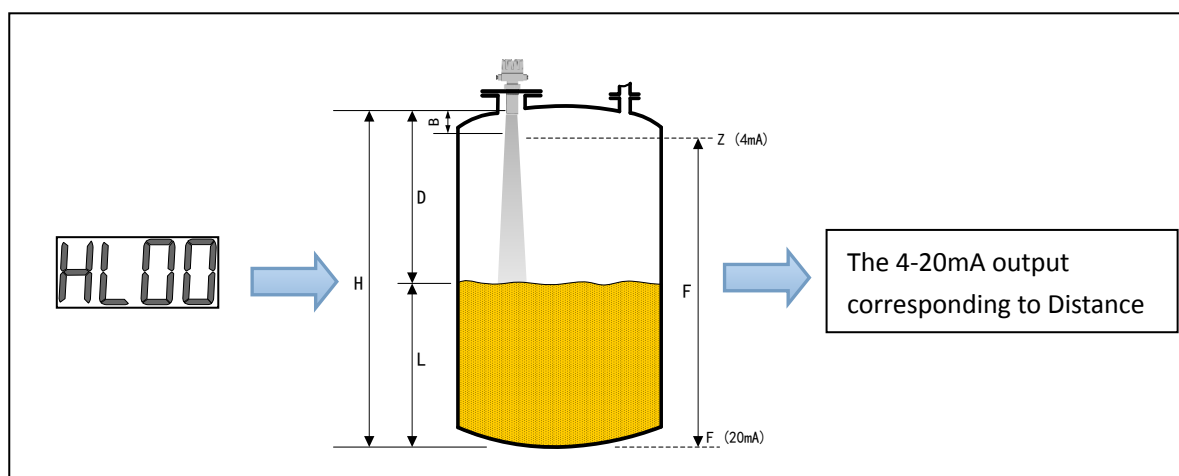
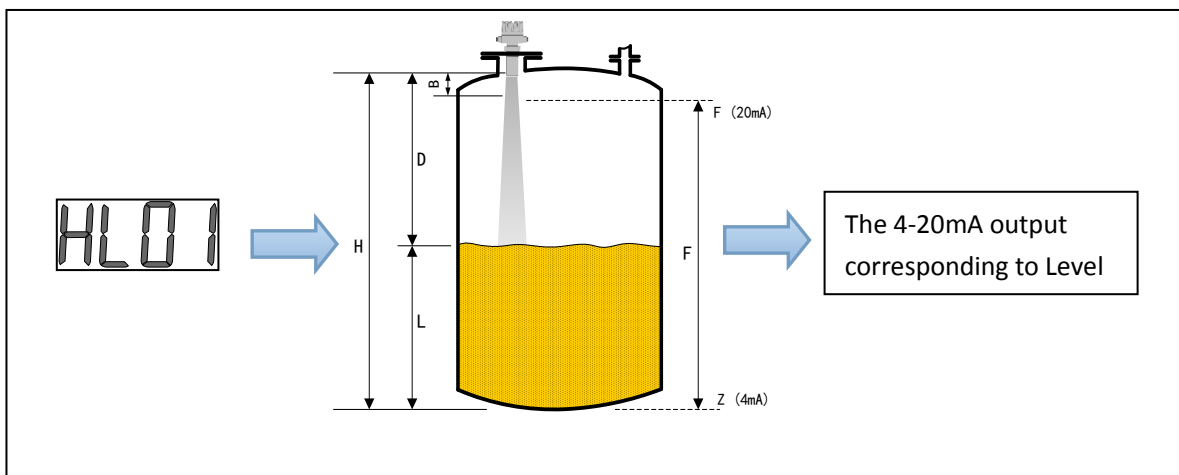

The inner password

The fourth parameter in the setting mode is inner password for further settings. Please do not set this parameter without the guidance from manufactory. Press **SEL** to leave this parameter, or press **MOV** and **SEL** simultaneously to quit from setting mode and enter into the normal mode.

MOUNTING

Reasonable installation is critical factor of the instrument's normal working. Installation must be carried out by trained person in accordance with the manual. The temperature of the process may not exceed 75°C, and the pressure may not exceed ±0.1 MPa.

Dimensions

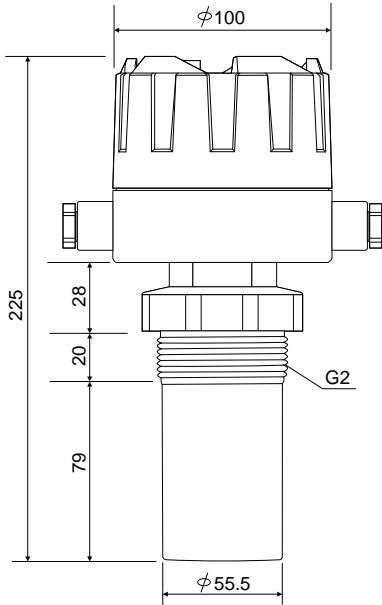

Range: 4m, 6m, 8m

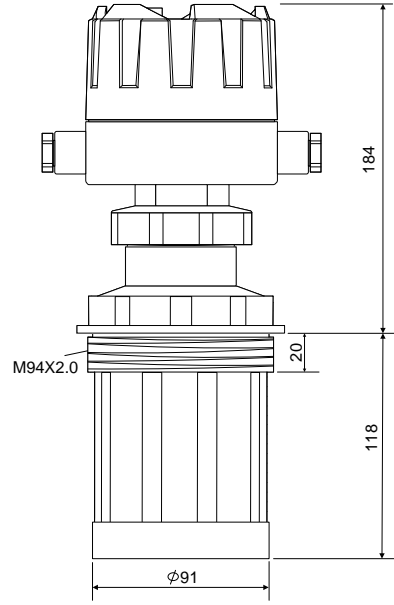

Range: 10m (12m), 15m, 20m, 30m.

Mounting method

Angel mount:

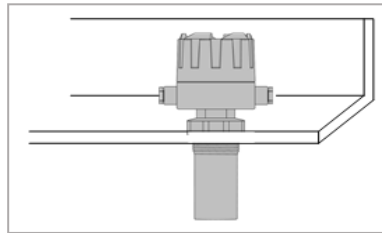

Flange mount:

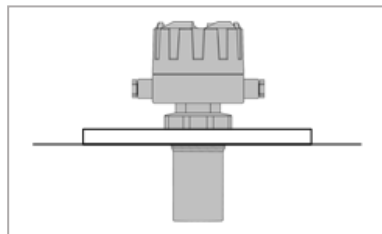

Mounting Considerations

① The beam angle is 8° , in order to avoid large echo loss and false echo, the probe should not be mounted closer than 1 m to the wall.

It is advisable to maintain a distance of at least 0.6m from the center line of the probe for every foot (10cm per meter) range to the obstruction.

② Make sure the distance between the probe and the maximum level exceeds the blind zone, because the probe cannot detect any liquid or solid surface closer than the blind zone to the probe's face.

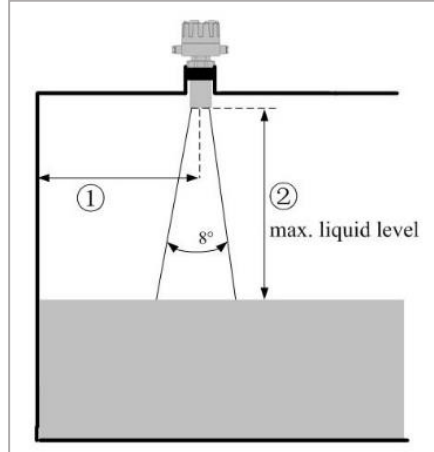

③ The meter must be installed in a position to obtain unobstructed echoes from the liquid or material being measured. Install the instrument at right angles to the surface of the measuring material, especially for solid measurement.

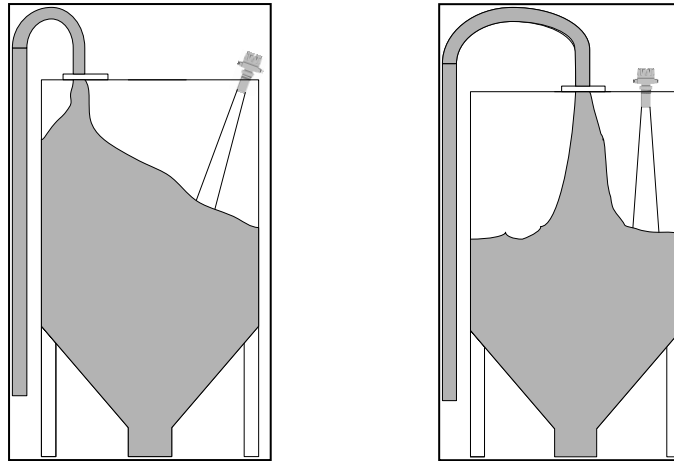

④ Mount the meter away from pipes, ladders or structural members which might cause continuous false echoes.

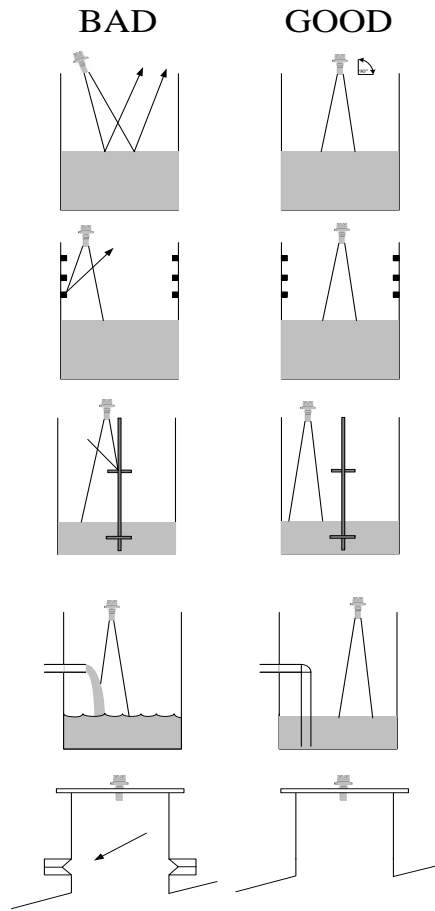

⑤ Foaming liquids can reduce the size of the returned echo because foam is a poor ultrasonic reflector. Mount an ultrasonic transmitter over an area of clear liquid, such as near the inlet to a tank or well. In extreme conditions, or where this is not possible, the transmitter may be mounted in a vented stilling tube provided that the inside measurement of the stilling tube is at least 4 in. (100 mm) and is smooth and free from joints or protrusions. It is important that the bottom of the stilling tube stays covered to prevent the ingress of foams.

Liquid surface turbulence is not normally a problem unless it is excessive. The effects of turbulence are minor, but excessive turbulence can be dealt with by advising the technical parameters or a stilling tube.

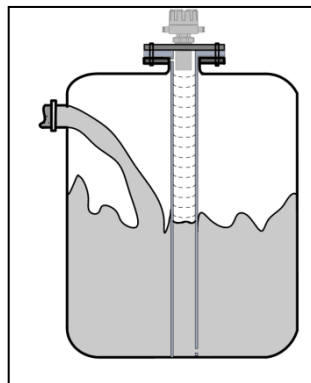

- ⑥ When installed on top of the arch or conical containers, please avoid the center.

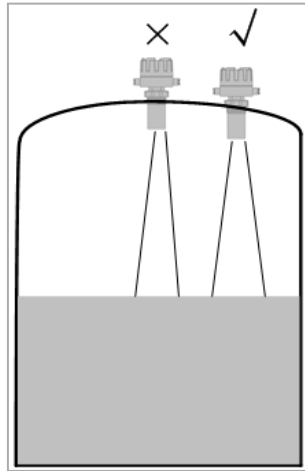

- ⑦ When install to the cold area, should choose the lengthen sensor of the level meter , make the sensor extend into the container, shun frost and icing .

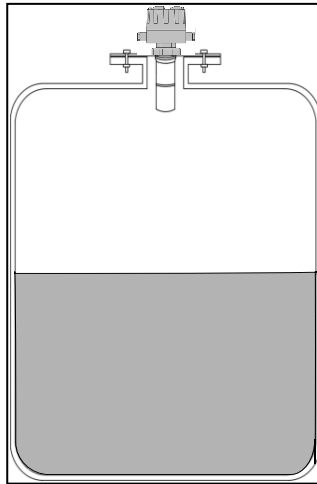

- ⑧ The probe must extend into the container (for the range more than 8m).
The standpipe length should be as short as possible, and its diameter as large as possible.

For range 10m, 15m, 20m, 30m

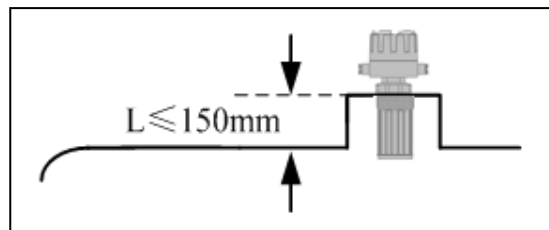

For range 4m, 6m, 8m.

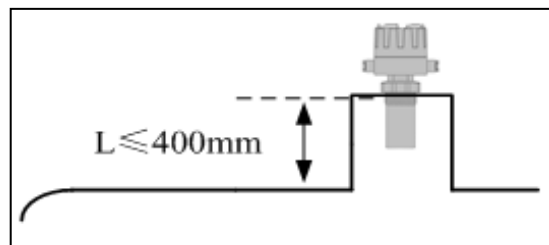

- ⑨ The use of metallic fittings or flanges is not recommended.
- ⑩ For exposed or sunny locations a protective hood is recommended.
- ⑪ In non-linear tanks with rounded or conical bottoms, mount the transmitter off-center. If needed, a perforated reflector plate can be installed on the tank bottom directly under the transmitter center line to ensure a satisfactory return echo.

TROUBLE SHOOTING

Trouble Phenomenon	Trouble Reason	Solution
The instrument does not show, and does not work.	Power supply error. Wiring error.	Check the power supply. Check the wiring.
The instrument doesn't work but with show.	The sensor doesn't aim at the liquid or the material. The surface has great fluctuations. Liquid surface with lots of foam. The container is empty and the bottom is not flat. Over the range.	Adjust the sensor and aim at the material. Add a tube to the container. Add a tube to the container Use instrument with a lager range. Use instrument with a lager range.
The instrument shows unstable or the measured value has a great deviation.	The level enters the blanking distance. There is strong electromagnetic interference There is Obstruction of the ultrasonic wave.	Increase the installation height of the instrument. or prevent the level too high. Increase shielding to the instrument. Change the installation site or using a plastic tube.

NOTE: Because of AKTEK's policy of improving their products, the ALIT serie would be revised and improved. Please inform us about misunderstandings or errors which you may find in this manual comparing it to the device you bought. Do not hesitate to contact us to suggest how to improve our devices.
Thank you



İMES Sanayi Sitesi B Blok 204. Sk. No:40
Y. Dudullu Ümraniye - İstanbul
Tel:0216 540 7300 Faks: 0216 540 7303
www.aktek.com.tr info@aktek.com.tr